

| REV. | DESCRIPTION | DATE      | DRAFTER | APPROVER |
|------|-------------|-----------|---------|----------|
| A1   | DWG.REL     | 2020.6.02 | ZHANG   | JIN      |

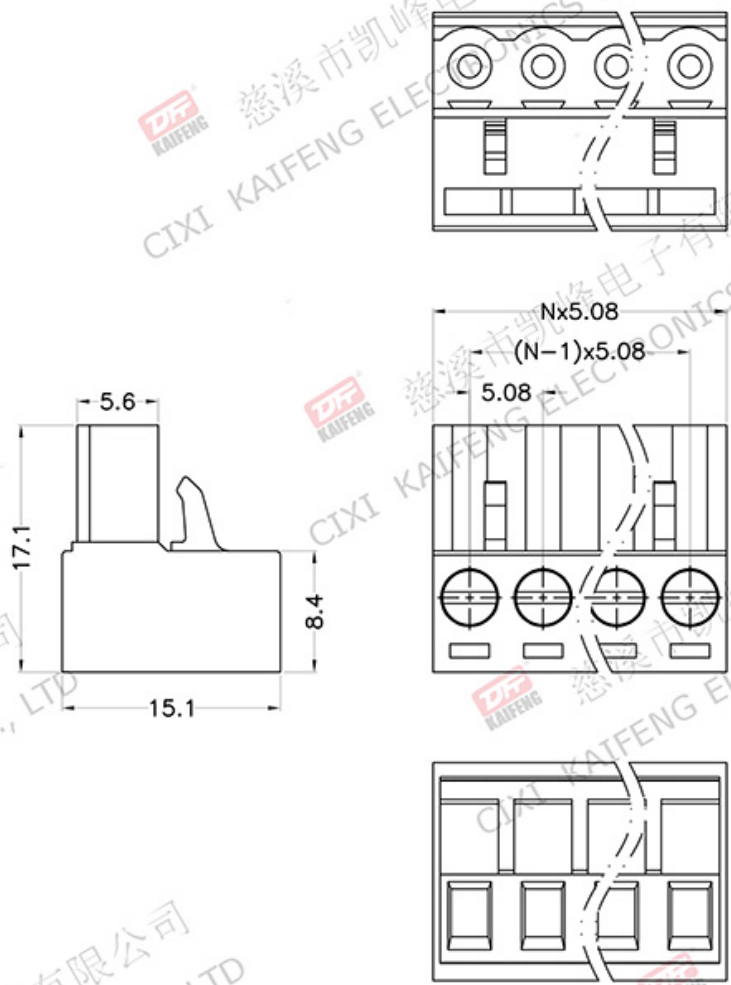

- Material
  - ØScrews : M3.0 steel, Zinc plated, "—" slot type
  - ØHousing : PA66, UL94V-0
  - ØContact : Copper alloy, Tin plated
  - ØClamp : Copper alloy, Ni plated
  - ØCover : PA66, UL94V-0
- Electrical
 

|                         | UL                          | IEC  |
|-------------------------|-----------------------------|------|
| Rated voltage :         | 300V                        | 320V |
| Rated current :         | 15A                         | 20A  |
| Contact resistance :    | 20mΩ(Max)                   |      |
| Insulation resistance : | 500MΩ/DC500V                |      |
| Withstanding Voltage :  | AC2000V/1min                |      |
| Wire range :            | 28-12AWG 2.5mm <sup>2</sup> |      |
- Mechanical
  - Operating temperature: -40°C~+105°C
  - Soldering temperature: 250°C±5/5sec
  - Torque: 0.5N.m (4.43Lb.in)
  - Strip length: 7-8mm
- RoHS compliance

**HOW TO ORDER**  
 KF2EDG-X-5.08-XXP-1 X-XXXXX

MODEL      Pitch:mm      No. of poles: 2~24P      Customer Request

Color:  
 G:Green      R:Red  
 K:Black      W:White  
 O:Orange      B:Blue  
 GR:Gray

1:Single Pitch  
 2:Double Pitch

| Pitch range             | Nominal dimension range | PROJECTION       | TITLE                |
|-------------------------|-------------------------|------------------|----------------------|
| >0 >6 >10               | >0 >30 >60 >100 >150    | 0.1/10           | KF2EDG-X-5.08-XXP-1X |
| ~6 ~10 ~24              | ~30 ~60 ~100 ~150       | UNIT             | mm                   |
| ±0.15 ±0.20 ±0.30 ±0.30 | ±0.50 ±0.70 ±1.00 ±1.30 | SHEET SIZE       | A4                   |
| DRAWING TYPE            |                         | CUSTOMER DRAWING |                      |
| SCALE                   |                         | 1:1 SHEET 1 OF 1 |                      |
| DRAWING NO.             |                         | W10000582        |                      |

**DF** 慈溪市凯峰电子有限公司  
 CIXI KAIFENG ELECTRONICS CO.,LTD