

VIEW	TOLERANCE	
	0-5	±0.1
	6-10	±0.25
UNIT: mm	11-50	±0.5
	51-100	±1
	101-250	±2
	251-500	±5
	501- 1000	±10
	1000-2000	±20

**TTAF
APPROVAL**

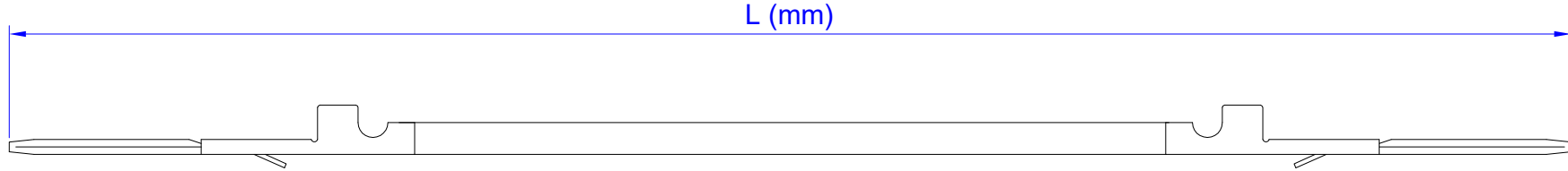

200G1-TP

200G1-TP

TTAF - 0 - YYYYY - ZZ - T

MANUFACTURER

CABLE

CABLE LENGTH
(mm)

TERMINAL
SERIES

CONNECTOR
TYPE

00-WHITE
01-BLACK
02-BLUE
03-GREEN
04-RED
05-PURPLE
06-BROWN
07-GRAY
08-PINK
09-ORANGE
10-YELLOW

2317 (2,5mm)
1800 (1,25mm)
5558 (mikrofit 3,0mm)
5557 (minifit 4,2mm)

T:SOCKET TO WIRE LEADS
C:SOCKET TO SOCKET

2	WW250-MT	Erkek Terminal	-	2	pcs.
1	KBL-15XX	UL1007 AWG24 KABLO (Tel sayısı:11, Tel çapı:0,16mm²)	-	1	pcs.
No	Metarial Code	Description	Size (mm)	Q'ty	Unit
Date	3.01.2023	Rev.	Revision Detail	Rev.Dt.	Rev.by
Designed by	Zeynep ŞAHİN				
Checked by	Ersin YÜKSEL				
					Part No
					TTAF-0-YYYY-ZZ-T
			Drawing Nr.	Scale	Sheet No
			-	NONE	1/1



Ürün	Akım Değeri	Voltaj Değeri	Dayanma Gerilimi	Çalışma Sıcaklığı
TTAF-0-YYYY-WW250MT-T	2.5A	250V	800VAC @ 60s	-40°C ~ +85°C

1

2

3

4

5

6

VIEW	TOLERANCE	
	0-10	±1
	11-250	±5
UNIT: mm	251-500	±10
	501-1000	±20
	1001-3000	±50
	3001-5000	±100
	5001- >	±150

Δ Order Code : **WW250-MT**

**TTAF
APPROVAL**

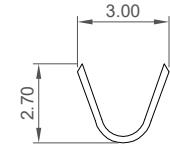
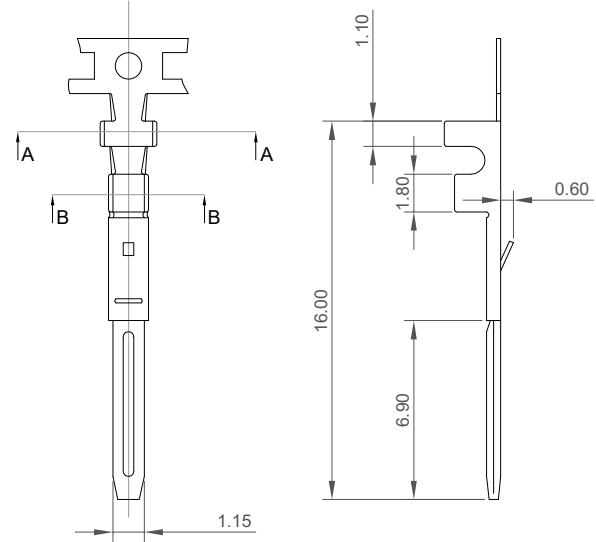
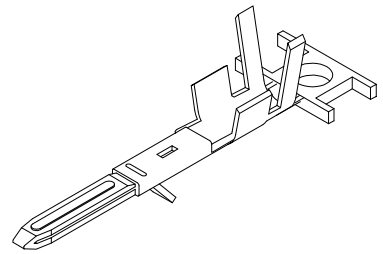

Sec:A-A

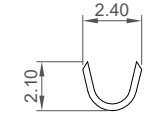

Sec:B-B

Wire Range	Insulation O.D.	Material	Finish	Qty/reel
AWG#22..#28	1.70 mm (max)	Brass	Tin-Plated	7.000 pcs

Date	27.04.2016	Rev.	-	Revision Detail		Rev.Dt.		Rev.by		Part No	WW250-MT	
Designed by	Yeşim AKSOY											
Checked by	Fatih BOLACA											
										Drawing Nr.	Scale	Sheet No
											NONE	1/1

1

2

3

4

5

6

Form No: FR-01/004 | Yr: 10/2003 Rev:06 09/01/2012

A4