

未注公差/General tolerances(mm)														
0	>3	>6	>10	>18	>30	>50	>80	>120	>180	>250	>315	>400	>500	0.1/10
~	~	~	~	~	~	~	~	~	~	~	~	~	~	±2'
±0.12	±0.18	±0.22	±0.26	±0.31	±0.37	±0.57	±0.80	±0.93	±1.05	±1.15	±1.60	±2.20	±2.50	

O2P:Clasp on the left from this view

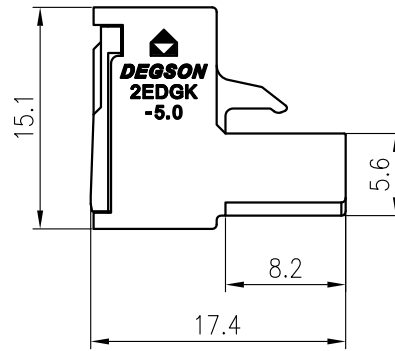
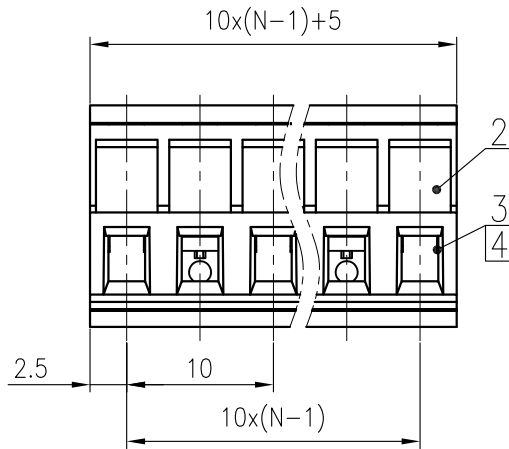
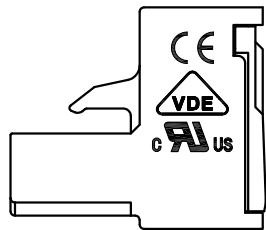
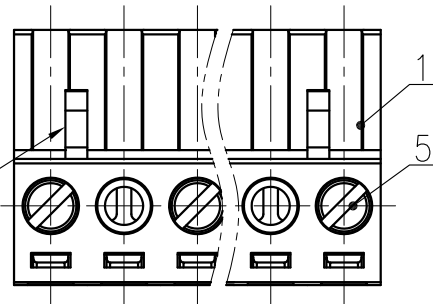

ITEM	NAME OF PART	MATERIAL	NOTES	
5	Screw	Steel	M2.5/Zn Plated	
4	Cage	Copper alloy	M2.5/Ni Plated	
3	Clamp	Copper alloy	Sn Plated	
2	Cover	PA66	UL94V-0	
1	Housing	PA66	UL94V-0	
JL 标准/UL Standard:		B	C	D
额定电压/电流/Rated Voltage(V)/Current(A)		300/15	/	300/10
IEC 标准/IEC Standard:				
过压类别/Overvoltage Category/污染等级/Pollution Degree		III/3	III/2	II/2
额定电压/电流/Rated Voltage(V)/Current(A)		/	320/20	/
额定脉冲电压(KV)/Rate Impulse Voltage(KV)		/	4	/
螺丝扭矩/Torque Tightening(N·m/Lb.in)		M2.5, 0.4/3.6		
线径范围(硬线和软线)/Wire Range(rigid and flexible)(AWG/mm <sup>2</sup> )		28~12/1.0~2.5		
间距/Pitch(mm)/线数范围/Poles		10/N=02~12P		
剥线长度/Stripping length(mm)		5~6		
使用温度范围/Operating temperature(°C)		-40~+105		
符合RoHS环保要求/Conform to RoHS		Yes		

MATERIAL:	/	SURFACE:	/
MAT NO.:		宁波高松电子有限公司 NINGBO DEGSON ELECTRICAL CO., LTD	
STATUS:	/		
APPD: Lan ChH 2020.12.18	NAME:	2EDGK-5.0-XXP-2Y-00A(H)	
CHKD:Gong YZh 2020.12.18	DRAWING NO.:	10003515	REV TO
DRFT: Yin DK 2020.12.18	TYPE: CUSTOMER DRAWING	SCALE: 2:1	SHEET 1/1

REV	ECN	DESCRIPTION	DRFT	DATE

Transfer or duplication of this document or communication of its contents are prohibited unless explicit authorization is granted. Violations will be liable for compensation. All rights reserved for patent, utility, model or designs registrations. 除非给予明确授权,否则禁止转让、复制、利用、交易本文件的内容。侵犯者将承担法律责任。 侵权必究并保留所有权利。