

REVISION RECORD				
REV	ECN	DESCRIPTION	DRFT	DATE

NOTES1:
 UL Standard
 1. Rated voltage/current : 300V / 15A
 2. Withstanding voltage : AC1600V/1Min.
 3. Torque value : M3 , 4.43Lb.in
 4. Wire range : 28~12AWG

IEC Standard

1.

Pollution degree	2
Overtoltage category	III
Rate impulse voltage(KV)	4.0KV
Rate voltage(V)	320V
Rate current(A)	18A

2. Torque value : M3 , 0.5N·m
 3. Wire range : 1.0~2.5mm²

NOTES2:
 1. Dimension shall be interpreted per ASME Y14.5-2009
 2. Pitch : 10.16mm, Poles : N=02~12P
 3. Stripping length : 7~8mm
 4. Operating temperature: -40°C~+105°C
 5. Undimensioned tolerances:

Pitch range in mm		Nominal dimension range in mm						0.1/10
TO	Over	Over	Over	Over	Over	Over		
6	6 TO 10	10 TO 24	30 TO 30	30 TO 60	60 TO 100	100 TO 150	150	
±0.15	±0.20	±0.30	±0.30	±0.50	±0.70	±1.00	±1.30	
							±2'	

6. RoHS Compliance

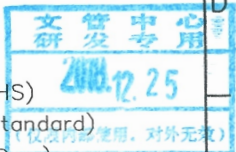

2EDGKA - 5.08 - XXP - 2Y - 1000A (H)
 (Series No.) (Pitch) (Poles) (Double Pitch) (Color): 1.(Grey)
 2.(Blue)
 3.(Black)
 4.(Green)
 5.(Orange)
 6.(Red)
 7.(Transparent)
 8.(Yellow)
 9.(White)

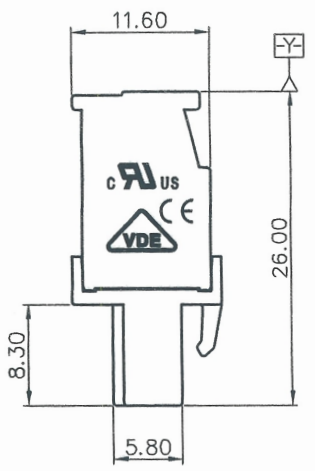
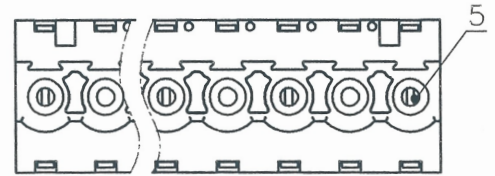
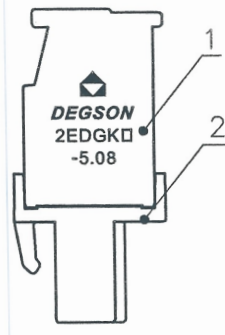
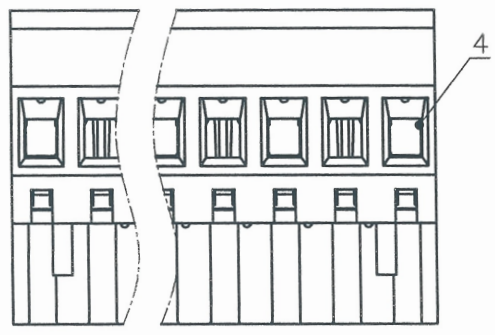
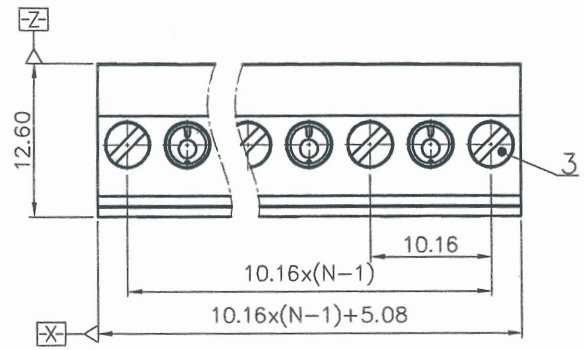

ITEM	NAME OF PART	MATERIAL	NOTES
5	Clamp	Copper Alloy	Sn Plated
4	Cage	Copper alloy	M3/Ni Plated
3	Screw	Steel	M3/Zn Plated
2	Cover	PA66	UL94V-0
1	Housing	PA66	UL94V-0

PART NO.:		宁波高松电子有限公司 NINGBO DEGSON ELECTRICAL CO., LTD		
APPD: <i>ZHOU</i>	NAME:	2EDGKA-5.08-XXP-2Y-1000A(H)		
CHKD: <i>Mark Zhang</i>	TITLE:	CUSTOMER DRAWING	REV	TO
DRFT: LYU 2018.12.21	DRAWING NO.:	2EDGKA-5.08-C51	SHEET	1/1
THIRD ANGLE PROJECTION		MM (INCH)	DO NOT SCALE DRAWING	SCALE 1:1

H
G
F
E
D
C
B
A

H
G
F
E
D
C
B
A