

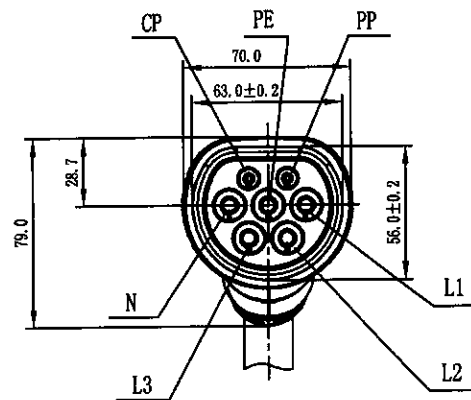

REVISION RECORD				
REV	ECN	DESCRIPTION	DRFT	DATE

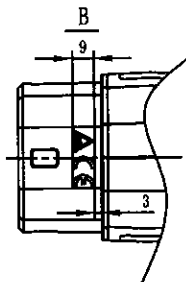

Wiring diagram

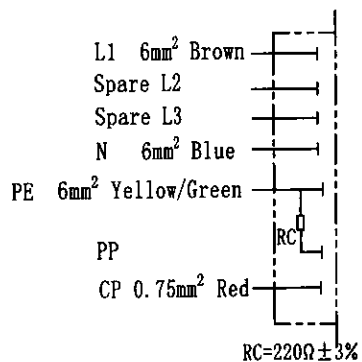

Customer Drawing

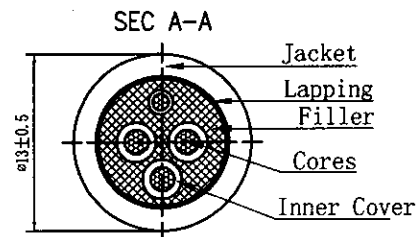
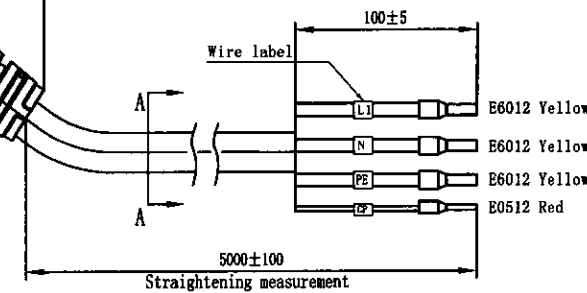
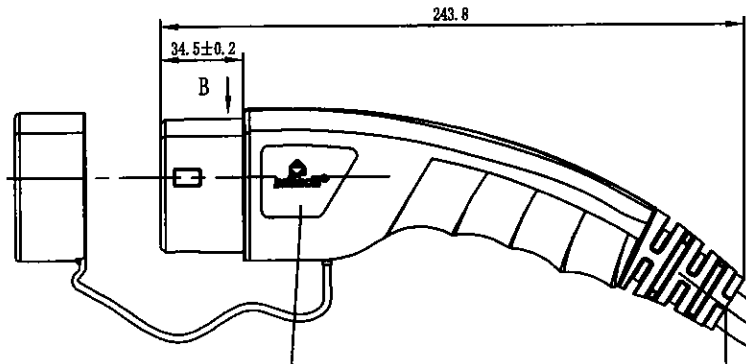

Laser Printing Front Note:  
  
 Laser Printing Back Note(Arial) :  
 MEAC-S-032A-V1-03-5.0M-121AH  
 32A 250V AC  
 IEC 62196-2:2016  
 IP54  
 20xxxxxx-xxxx



Technical parameters	
Rated voltage	250V AC
Rated current	32A
Temperature range	-30°C~+50°C
Insulate resistance	>5MΩ, 500V DC 1Min
Withstanding voltage	L, N AND PE, 2500V AC 1Min
	L AND N, 2500V AC 1Min
Ingress protection	IP54
The insertion/pullout times	10000 TIMES
Insertion/pullout force	<100N
Reference standard	IEC 62196-2:2016

NOTES:  
 1. Cable: EN50620-2017/IEC62893.3 EV 3\*6mm²+1\*0.75mm² Black  
 2. RoHS Compliance

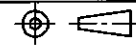
Size Measure Range	. XX	. X
≤6	±0.05	±0.10
6~30	±0.10	±0.20
30~120	±0.15	±0.30
120~400	±0.20	±0.50
400~1000	±0.30	±0.80
1000~2000	±0.50	±1.20
Angle Measure Range	. XX	. X
	±0.5°	±1.0°

PART NO. : /	 宁波高松电子有限公司 NINGBO DEGSON ELECTRICAL CO., LTD		
APPD: ZX 10700330	NAME: Vehicle Connector (32A AC single phase)		
CHKD: /	MEAC-S-032A-V1-03-5.0M-121AH		
DRFT: LLL 2020-03-27	TITLE: Customer Drawing	REV	DO-1
 THIRD ANGLE PROJECTION	DRAWING NO. : /	SHEET	1/1
	 (INCH) DO NOT SCALE DRAWING	SCALE	1:3