

# 5V Electromagnet (35 Kg Holding Force)

## INTRODUCTION

Note: The wire color is random.

This is a DC sucker type electromagnet with 35kg holding force and 3W power. It should be operated at 5V. The magnetic poles of the electromagnet can be changed by swapping the negative and positive poles of the input power. With a pretty small body, this electromagnet can be applied to DIY electromagnetic lock, smart storage cabinet, and intelligent door, etc.

Electromagnetic usually consists of a coil of wire wrapped around an iron core. When currents pass through the wire coil, a magnetic field, which makes the iron core magnetised, like a permanent magnet. The iron core material should be made of pure iron or silicon steel which is easy to be magnetized and demagnetized. In this way, it will be magnetic when powered on and lose magnetism quickly after power-down.

Note:

1. electromagnets are specified with "holding force", say 35Kg. This is not how much weight they can pick up! Divide the holding force by 5-10 to get a rough estimate of how heavy a thing it can pick up. So in this case, about 7 Kg max. Note that pick-up weight also depends on a flat surface and max surface contact, and the ferromagnetic metal content. A perfectly flat steel cube will work great, something oddly shaped or covered in rubber or plastic will not!

2. The electromagnet can withstand long-term electrify when attracted onto the surface of an object, but it should not be electrified for a long time when there is nothing to attract.

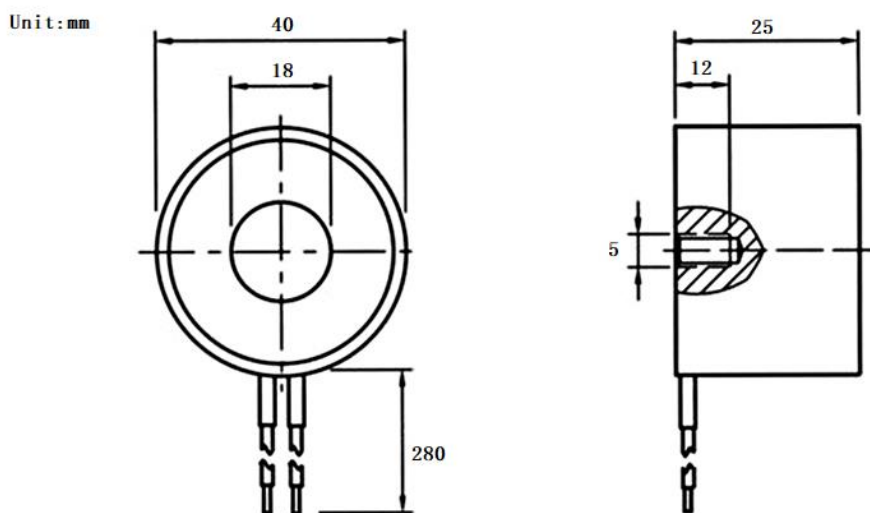

Dimension

## **SPECIFICATION**

Rated Voltage: DC 5V

Rated Power: 3W

Holding Force: 35kg

Wire Length: 28cm

## **SHIPPING LIST**

5V Electromagnet (35 Kg Holding Force) x1

Mounting Screw x1

