

# SPECIFICATION FOR APPROVAL

CUSTOMER :	DWG.NO: TD1212208
PART NO: LFU10V-182	CUST.DWG.NO :
CUSTOMER PART NO :	DOC : Y022208

(1) UNIT: mm

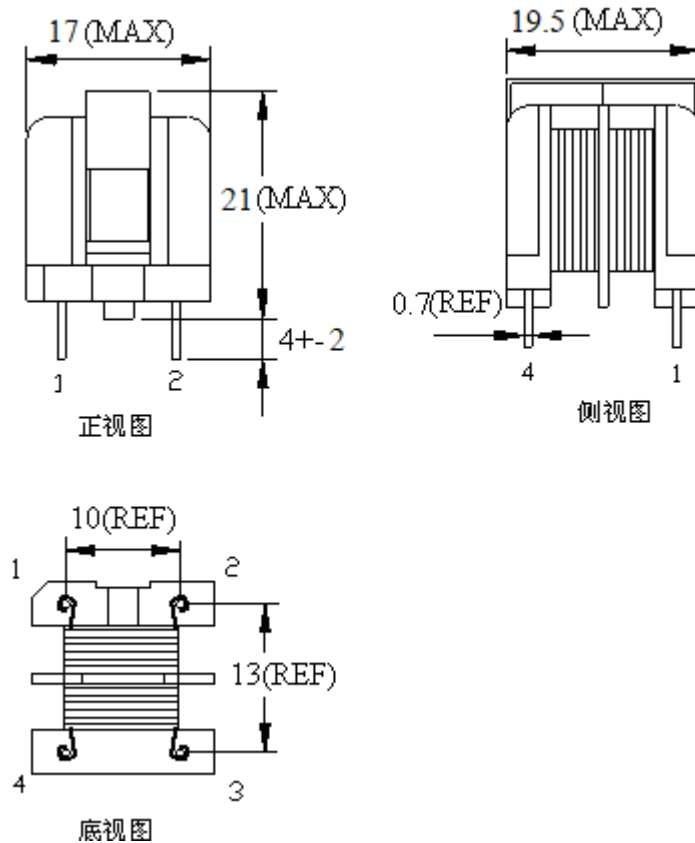

(2) SCHEMATIC:

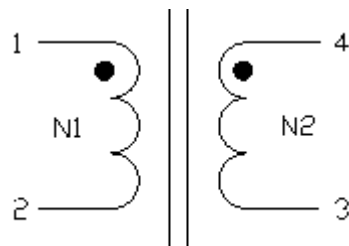

DRAWN BY	CHECKED BY	APPROVED BY
黃慧診	張明德	Yumi

**CORE MASTER ENTERPRISE CO., LTD.**

TEL:886-2-8919-1288    FAX:886-2-8919-1298    WEB:www.coremaster.com.tw

# SPECIFICATION FOR APPROVAL

CUSTOMER :		DWG.NO: TD1212208	
PART NO: LFU10V-182		CUST.DWG.NO :	
CUSTOMER PART NO :		DOC : Y022208	
PARAMETER	TERMINAL	SPECIFICATION	TEST INSTRUMENTS
INDUCTANCE	L (1-2),(4-3)	1.8mH (MIN)	1KHz/0.25V
RDC ( $\Omega$ )	RDC (1-2)=(4-3)	0.6 (MAX)	25°C
IDC (A)	IDC (1-2)=(4-3)	1.0 (MAX)	
HI-POT	PIN1-PIN4	AC 1.8KV/5mA/1SEC	
	PIN1,4-CORE	AC 1.0KV/5mA/1SEC	
MATERIAL	SPEC	SUPPLIER	REMARK
CORE	UU10.5 R10K	VAKOS OR EQU	
WIRE	2UEW $\phi$ 0.4	TAI-I OR EQU	
BOBBIN	UU10.5 PLENOLIC T375J	CHANGCHUN	
DRAWN BY		CHECKED BY	APPROVED BY
黃慧診		張明德	Yumi

**CORE MASTER ENTERPRISE CO., LTD.**

TEL:886-2-8919-1288    FAX:886-2-8919-1298    WEB:www.coremaster.com.tw

# SPECIFICATION FOR APPROVAL

CUSTOMER :			DWG.NO: TD1212208		
PART NO: LFU10V-182			CUST.DWG.NO :		
CUSTOMER PART NO :			DOC : Y022208		
繞組	START	END	WIRE SIZE	TURNS(TS)	TAPE(TS)
N1	1	2	Φ0.4	36(REF)	
N2	4	3	Φ0.4	36(REF)	
DRAWN BY		CHECKED BY		APPROVED BY	
黃慧診		張明德		Yumi	

**CORE MASTER ENTERPRISE CO., LTD.**

TEL:886-2-8919-1288    FAX:886-2-8919-1298    WEB:www.coremaster.com.tw