



深圳市一众显示科技有限公司

SHEN ZHEN TEAM SOURCE DISPLAYTECH. CO, TD.

TFT-LCD Module Specification

Module NO.: TST28011T-00P

Version: V1.0

APPROVAL FOR SPECIFICATION

APPROVAL FOR SAMPLE

For Customer' s Acceptance:	
Approved by	Comment

Team Source Display:		
Presented by	Reviewed by	Organized by

Version No.	Date	Content	Remark
V1.0	2016-5-14	Initial Release	

CONTENTS

1 GENERAL CHARACTERISTICS.....	- 3 -
2 PRODUCT DRAWINGS.....	- 4 -
3 INTERFACE DESCRIPTION.....	- 5 -
4 LCM INTERFACE TIMING.....	- 6 -
4.1 RESET TIMING.....	- 6 -
4.2 MCU READ/WRITE TIMING.....	- 6 -
5 INITIAL CODE.....	- 7 -
6 ABSOLUTE MAXIMUM RATINGS.....	- 10 -
7 ELECTRICAL CHARACTERISTICS.....	- 10 -
8 BACKLIGHT CHARACTERISTICS.....	- 10 -
9 LCD OPTICAL SPECIFICATIONS.....	- 11 -
10 RELIABILITY TEST.....	- 13 -
11 INSPECTION STANDARDS.....	- 14 -
11.1 VISUAL INSPECTION CRITERION IN COSMETIC.....	- 14 -
11.1.1 Glass defect.....	- 14 -
11.1.2 LCM appearance defect.....	- 14 -
11.1.3 FPC.....	- 15 -
11.1.4 Black tape.....	- 15 -
11.1.5 Silicon.....	- 15 -
11.2 VISUAL INSPECTION CRITERION IN ELECTRICAL DISPLAY.....	- 15 -
11.3 OTHERS.....	- 16 -
12 SUGGESTIONS FOR USING LCD MODULES.....	- 16 -
12.1 HANDLING OF LCM.....	- 16 -
12.2 STORAGE.....	- 16 -

1 General Characteristics

ITEM	Specification	Unit
LCD Type	a-Si TFT, Transmissive, Normally white, TN	-
LCD Size	2.8	inch
Resolution (W x H)	240 x (RGB) x 320	pixel
LCM (W x H x D)	50.0(W) x 69.2(H) x 2.25(D)	mm
Active Area (W x H)	43.2 (W) x 57.6 (H)	mm
Dot Pitch (W x H)	0.180 (W) x 0.180 (H)	mm
Viewing Direction	6 o'clock	-
Gray Scale Inversion Direction	12 o'clock	-
Viewing Angle	Top:30, Bottom:65; Left/ Right:60	deg.
Color Depth	65K/262K	-
Pixel Arrangement	RGB Vertical stripe	-
Backlight Type	4 LEDs, 80mA	-
Surface Luminance	250	cd/m ²
Surface Treatment	Anti-Glare	-
Polarizer	0.22mm, EWV	-
Driver IC	ILI9341V	-
Interface Type	MCU 8/16-bit	-
Input Voltage	2.8	V
With/Without TP	With RTP	-
Weight	TBD.	g

Note 1: RoHS compliant

Note 2: LCM weight tolerance: ± 5%.

3 Interface description

PIN NO.	Symbol	description
1~4	DB0~DB3	Data BUS
5	GND	System Ground. (0V)
6	IOVCC	Power supply +2.8V or 1.8V
7	CS	Chip select signal.
8	RS	Data/Command Selection pin
9	WR	write signal
10	RD	read signal
11	NC	
12	X+/XR	The touch panel X Right pin
13	Y+/YU	The touch panel Y UP pin
14	X-/XL	The touch panel X Left pin
15	Y-/YD	The touch panel Y Down pin
16	LEDA	Backlight A Anode input pin.
17~20	LEDK1~LEDK4	Backlight K Cathode input pin.
21	GND	System Ground. (0V)
22	DB4	Data BUS
23~30	DB8~DB15	Data BUS
31	RESET	Reset input signal
32	VCI	Power supply +2.8V
33	VCC	Power supply +2.8V or 1.8V
34	GND	System Ground. (0V)
35~37	DB5~DB7	Data BUS

4 LCM Interface Timing

4.1 Reset Timing

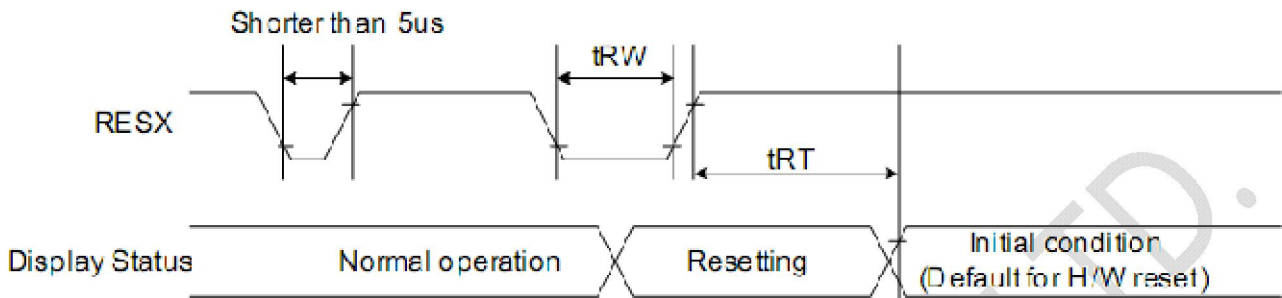

Signal	Symbol	Parameter	Min	Max	Unit
RESX	tRW	Reset low pulse width	10	-	us
	tRT	Reset complete time	-	5 (note 1)	ms
			-	120(note 2)	ms

Note: (1) When reset applied during SLPIN mode;

(2) When reset applied during SLPOUT mode.

4.2 MCU Read/Write Timing

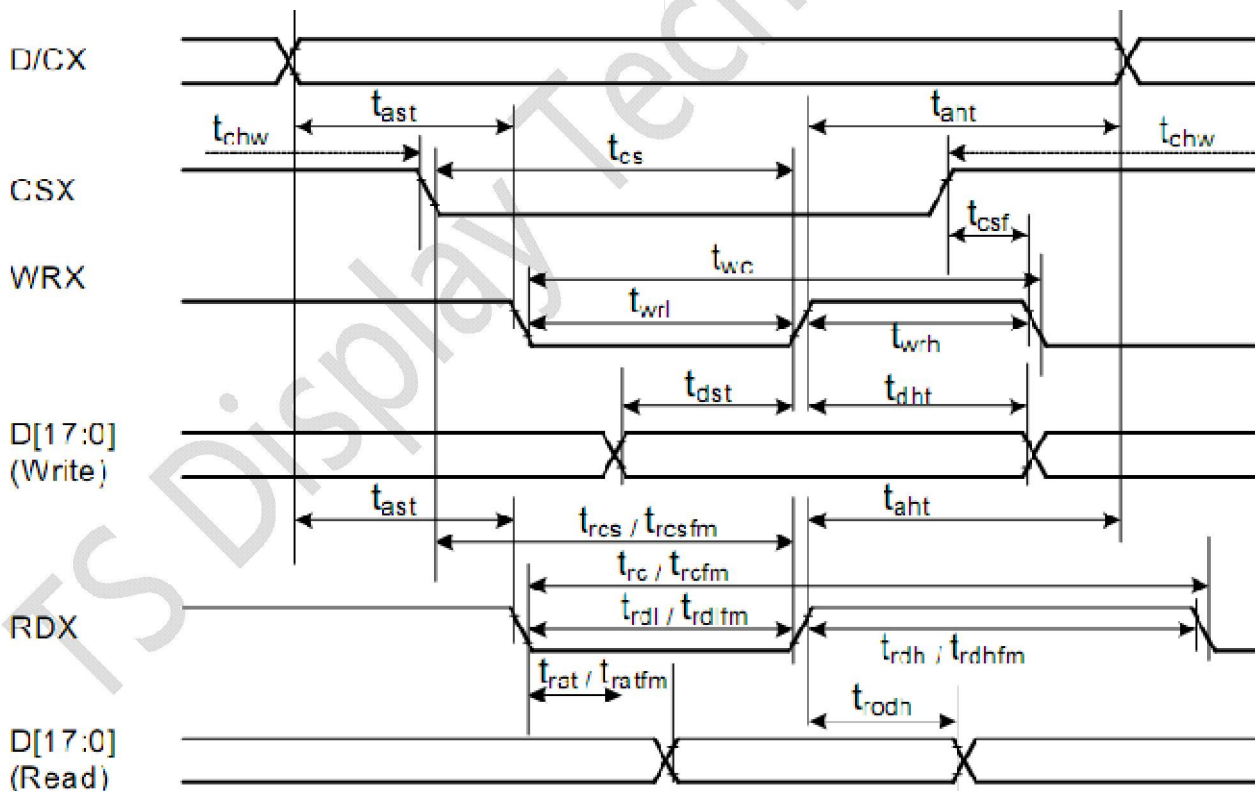

(Ta = 30 to 70 °C, IOVCC=1.65V to 3.3V, VCC=2.5V to 3.3V, VSS=0V)

Signal	Symbol	Parameter	min	max	Unit	Description
DCX	tAST	Address setup time	0	-	ns	-
	tAHT	Address hold time (Write/Read)	0	-		
CSX	tCS	Chip select setup time (Write)	15	-	ns	-
	tRCS	Chip select setup time (Read register)	45	-		
	tRCSFM	Chip select setup time (GRAM)	355	-		
	tCSF	Chip select wait time (Write/Read)	10	-		
WRX	tWC	Write cycle (write register)	66	-	ns	-
	tWRH	Control pulse "H" duration	15	-		
	tWRL	Control pulse "L" duration	15	-		
RDX	tRC	Read cycle (read register)	160	-	ns	-
	tRC	Read cycle (GRAM)	450	-		
	tRDH	Control pulse "H" duration	90	-		
	tRDL	Control pulse "L" duration(read register)	45	-		
	tRDL	Control pulse "L" duration(GRAM)	355	-		
DB[23:0]	tDST	Data setup time	10	-	ns	For maximum CL=30pF For minimum CL=8pF
	tDHT	Data hold time	10	-		
	tRAT	Read access time(read register)	-	40		
	tRAT	Read access time(GRAM)	-	340		
	tODH	Output disable time	20	80		

Note: The input signal rise time and fall time (tr, tf) is specified at 15 ns or less.
 Logic high and low levels are specified as 30% and 70% of IOVCC for Input signals.

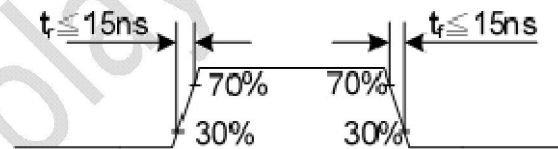

5 INITIAL CODE

```

LCD_REST=0;// Hardware reset
Delayms(15);
LCD_REST=1;
Delayms(120);
//***** Start Initial Sequence *****/

write_reg(0xF6);
write_dat (0x01);
write_dat (0x33);

write_reg(0xB5);
write_dat (0x04);
write_dat (0x04);
    
```

```
write_dat (0x0A);  
write_dat (0x14);
```

```
write_reg(0x35);  
write_dat (0x00);
```

```
write_reg(0xCF);  
write_dat (0x00);  
write_dat (0xEA);  
write_dat (0XF0);
```

```
write_reg(0xED);  
write_dat (0x64);  
write_dat (0x03);  
write_dat (0X12);  
write_dat (0X81);  
write_reg(0xE8);  
write_dat (0x85);  
write_dat (0x00);  
write_dat (0x78);
```

```
write_reg(0xCB);  
write_dat (0x39);  
write_dat (0x2C);  
write_dat (0x00);  
write_dat (0x33);  
write_dat (0x06);
```

```
write_reg(0xF7);  
write_dat (0x20);  
write_reg(0xEA);  
write_dat(0x00);  
write_dat(0x00);
```

```
write_reg(0xC0); //Power control  
write_dat(0x21); //VRH[5:0]  
write_reg(0xC1); //Power control  
write_dat(0x10); //BT[3:0]
```

```
write_reg(0xC5); //VCM control  
write_dat(0x4F);  
write_dat(0x38);  
write_reg(0xC7); //VCM control2  
write_dat(0xA5);
```



```
write_reg(0x36); // Memory Access Control
write_dat(0x08);
write_reg(0x3A);
write_dat (0x55); //RGB565

write_reg(0xB1);
write_dat(0x00);
write_dat(0x13);
write_reg(0xB6); // Display Function Control
write_dat(0x0A);
write_dat(0xA2);

write_reg(0xF2); // 3Gamma Function Disable
write_dat(0x02);

write_reg(0xE0); //Set Gamma
write_dat (0x0F);
write_dat (0x27);
write_dat (0x24);
write_dat (0x0C);
write_dat (0x10);
write_dat (0x08);
write_dat (0x55);
write_dat (0X87);
write_dat (0x45);
write_dat (0x08);
write_dat (0x14);
write_dat (0x07);
write_dat (0x13);
write_dat (0x08);
write_dat (0x00);

write_reg(0xE1); //Set Gamma
write_dat (0x00);
write_dat (0x0F);
write_dat (0x12);
write_dat (0x05);
write_dat (0x11);
write_dat (0x06);
write_dat (0x25);
write_dat (0x34);
write_dat (0x37);
write_dat (0x01);
```

```

write_dat (0x08);
write_dat (0x07);
write_dat (0x2B);
write_dat (0x34);
write_dat (0x0F);
write_reg(0x11);    //Exit Sleep
Delaysms(120);
write_reg(0x29);    //Display on
    
```

6 Absolute Maximum Ratings

PARAMETER	SYMBOL	MIN	MAX	UNIT
Supply Voltage (Analog)	VCC~GND	-0.3	4.6	V
Logic signal voltage(I/O)	IOVCC~GND	-0.3	4.6	V
Operating Temperature	Top	-20	70	° C
Storage Temperature	Tst	-30	80	° C
Operating Ambient Humidity	Hop	10	90%(Max 60° C)	RH

7 Electrical Characteristics

PARAMETER	SYMBOL	MIN	TYP	MAX	UNIT
Analog operating voltage	VCC	2.5	2.8	3.3	V
Logic operating voltage	IOVCC	1.65	1.8	3.3	V
Input Current	IDD	-	TBD	-	mA
Input Voltage ' H ' level	VIH	0.7IOVCC	-	IOVCC	V
Input Voltage ' L ' level	VIL	GND	-	0.3IOVCC	
Output Voltage ' H ' level	VOH	0.8IOVCC	-	IOVCC	
Output Voltage ' L ' level	VOL	GND	-	0.2IOVCC	

8 Backlight Characteristics

ITEM	SYMBOL	MIN	TYP	MAX	UNIT
Voltage for LED backlight	V _f	-	3.2	3.4	V
Current for LED backlight	I _f	-	80	-	mA
Power consumption	W _{bl}	-	256	-	mW
Uniformity	Avg	80	-	-	%
LED Life Time	-	30000	40000	-	Hrs

Note:

1. The LED life time is defined as the module brightness decrease to 50% original brightness at Ta=25°C, 60%RH ±5 %.
2. The life time of LED will be reduced if LED is driven by high current, high ambient temperature and humidity conditions.
3. Typical operating life time is an estimated data.
4. Permanent damage to the device may occur if maximum values are exceeded or reverse voltage is loaded .Functional operation should be restricted to the conditions described under normal operating conditions.

9 LCD optical specifications

Item	Symbol	Condition	Specification			Unit	Remark
			Min	Typ	Max		
Response time (By Quick)	Tr+Tf	$\theta = 0^\circ$	-	30	40	ms	Note 5
Contrast ratio	CR	$\theta = 0^\circ$	600	800	-		Note 2,6
Viewing angle	Top	$CR \geq 10$	-	30	-	Deg.	Note 2,6,7
	Bottom	$CR \geq 10$	-	65	-		
	Left	$CR \geq 10$	-	60	-		
	Right	$CR \geq 10$	-	60	-		
Color chromaticity (CF only with ITO, light source is C light, CIE 1931)	Wx	$\theta = 0^\circ$	0.288	0.308	0.328		Note 3
	Wy		0.310	0.333	0.350		
	Rx		0.621	0.641	0.661		
	Ry		0.317	0.337	0.357		
	Gx		0.254	0.274	0.294		
	Gy		0.540	0.560	0.580		
	Bx		0.121	0.141	0.161		
	By		0.093	0.113	0.133		
NTSC			60%			Note 3	
Transmittance (with Polarizer)	T(%)	$\theta = 0^\circ$	-	4.63	-	%	
Transmittance (without Polarizer)	T(%)	$\theta = 0^\circ$	-	17.5	-	%	Note 4

Note 1: Ambient temperature = 25°C.

Note 2: To be measured with a viewing cone of 2° by Topcon luminance meter BM-5A.

Note 3: To be measured with Otsuta chromaticity meter LCF-2100M, CF only measure under C light simulation.

Note 4: HSD shipping status is cell without polarizer. Transmittance of Specification is cell with polarizer.
The tolerance of Transmittance is ±10%.

Note 5: Definition of response time:

The output signals of TRD-100 are measured when the input signals are changed to “White” (falling time) and from “White” to “Black” (rising time), respectively. The interval is between the 10% and 90% of amplitudes. Refer to figure as below.

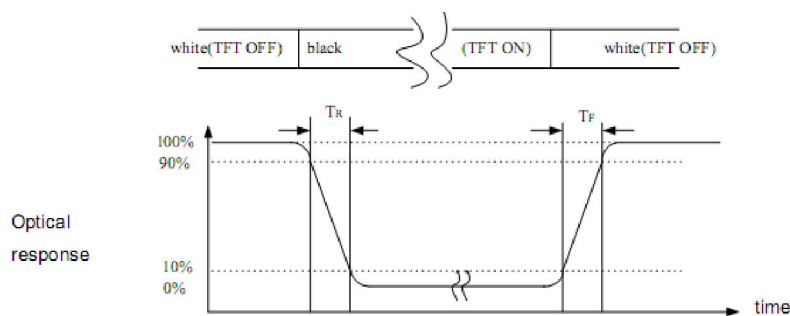

Note 6: Definition of contrast ratio:

Contrast ratio is calculated by the following formula.

$$\text{Contrast ratio (CR)} = \frac{\text{Brightness on the "white" state}}{\text{Brightness on the "black" state}}$$

Note 7: Definition of viewing angle

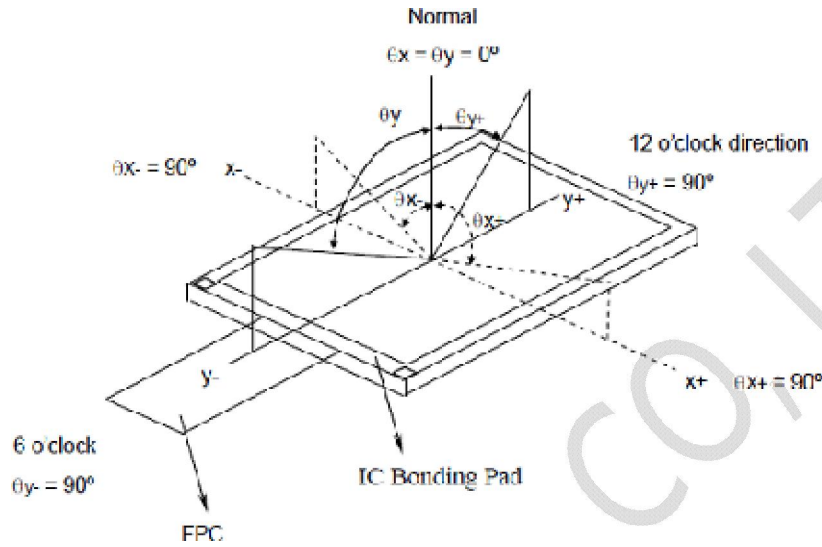

Note 8: Optical characteristic measurement setup.

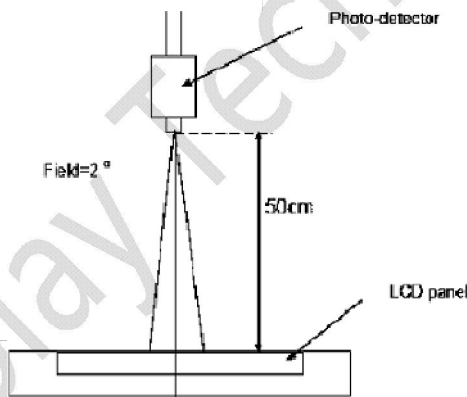

Note 9:

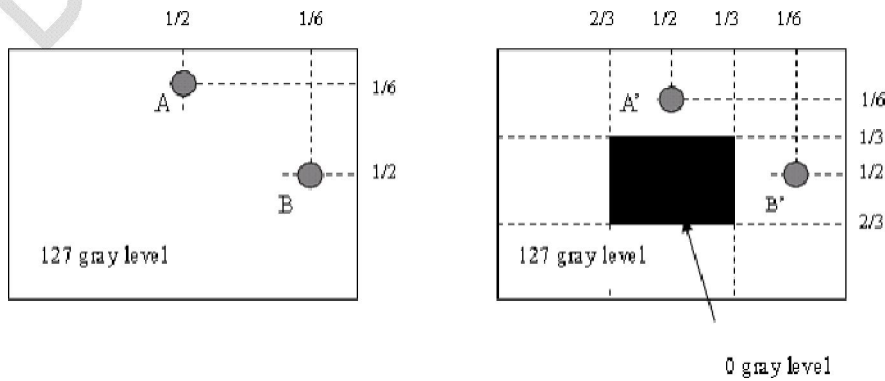

1 $|LA - LA'| / LA \times 100\% = 2\%$ max., LA and LA' are brightness at location A and A'.

1 $|LB - LB'| / LB \times 100\% = 2\%$ max., LB and LB' are brightness at location B and B'.

10 Touch Panel specifications

ITEM	VALUE			UNIT	REMARK
	Min	Typ	Max		
Linearity	-	-	1.5	%	Analog X and Y directions
Terminal Resistance	200	-	900	Ω	x
	200	-	900		y
Insulation Resistance	20	-	-	M Ω	DC 25V
Voltage	-	3	10	V	DC
Chattering	-	-	10	ms	100k Ω pull-up
Transparency	80	-	-	%	-
Operation Force	20	-	100	g	-
Endurance	1,000,000	-	-	Touches	100g Operation Force
	-	-	30,000	Slides	
Surface Hardness	3	-	-	H	-

11 RELIABILITY TEST

NO.	TEST ITEM	TEST CONDITION	INSPECTION AFTER TEST
1	High Temperature Storage	80 \pm 2 $^{\circ}$ C/96 hours	Inspection after 2~4 hours storage at room temperature and humidity. The condensation is not accepted. The sample shall be free from defects: 1. Air bubble in the LCD 2. Seal leak 3. Non-display 4. Missing segments 5. Glass crack
2	Low Temperature Storage	-30 \pm 2 $^{\circ}$ C/96 hours	
3	High Temperature Operating	70 \pm 2 $^{\circ}$ C/96 hours	
4	Low Temperature Operating	-20 \pm 2 $^{\circ}$ C/96 hours	
5	Temperature Cycle	-30 \pm 2 $^{\circ}$ C ~ 25~ 80 \pm 2 $^{\circ}$ C \times 10 cycles (30 min.) (5min.) (30min.)	
6	Damp Proof Test	60 $^{\circ}$ C \pm 5 $^{\circ}$ C \times 90%RH/96 hours	
7	Vibration Test	Frequency 10Hz~55Hz Stroke: 1.5mm Sweep: 10Hz~150 Hz~10Hz 2 hours For each direction of X, Y, Z	
8	Shock Test	Half-sine, wave, 300m/s	
9	Packing Drop Test	Height: 80 cm 1 corner, concrete floor	
10	Electrostatic Discharge Test	C=150pF, R=330 Ω Air: \pm 8KV 150pF/330 Ω 30 times Contact: \pm 4KV,20 times	

12 Inspection standards

12.1 Visual inspection criterion in cosmetic

12.1.1 Glass defect

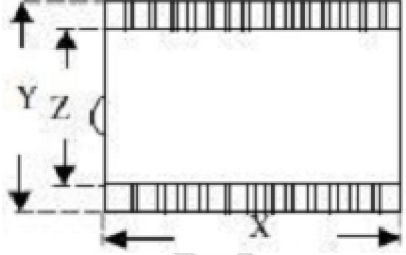
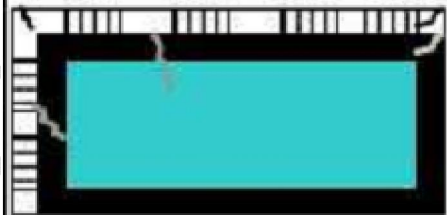
NO.	Defect	Criteria	Remark
1	Dimension(Minor)	By engineering diagram	
2	Cracks(Major)	Extensive crack [Reject]	

12.1.2 LCM appearance defect

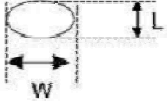
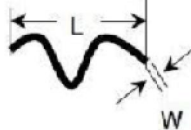
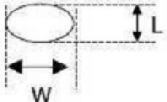
NO.	Defect	Criteria		Remark
		Spec	Permissible Qty	
1	Round type(Minor)	$\phi \leq 0.1\text{mm}$	Disregard	1. $\phi = (W+L)/2$, L:Length,W=Width 2.Disregard if out of A.A 
		$0.1\text{mm} < \phi \leq 0.2\text{mm}$	3	
		$\phi > 0.2\text{mm}$	0	
2	Line type(Minor)	$W \leq 0.03\text{mm}$	Disregard	1. L:Length,W=Width 2.Disregard if out of A.A 
		$L \leq 3.0\text{mm}$ and $0.03\text{mm} < W \leq 0.05\text{mm}$	2	
		$L \leq 3.0\text{mm}$ and $0.05\text{mm} < W \leq 0.1\text{mm}$	1	
		$W > 0.10\text{mm}$ or $L > 3.0\text{mm}$	0	
3	Polarizer dent(Minor)	$\phi \leq 0.2\text{mm}$	Disregard	1. $\phi = (W+L)/2$, L:Length,W=Width 2.Disregard if out of A.A 
		$0.2\text{mm} < \phi \leq 0.3\text{mm}$	2	
		$0.3\text{mm} < \phi \leq 0.5\text{mm}$	1	
		$\phi > 0.5\text{mm}$	0	

12.1.3 FPC

NO.	Defect	Criteria	Remark
1	Copper peeling(Minor)	Copper peeling [Reject]	
2	Damaged	Damaged[Reject]	

12.1.4 Black tape

NO.	Defect	Criteria	Remark
1	Shift(Minor)	IC exposed [Reject]	
2	No black tape(Minor)	No black tape [Reject]	

12.1.5 Silicon

NO.	Defect	Criteria	Remark
1	Amount of silicon (Minor)	ITO exposed [Reject]	

12.1.6 Touch Panel

Defect	Criteria	Remark
TP shift	Click on the TP, the distance between the show position and click position>1.5mm [Reject]	

12.2 Visual inspection criterion in electrical display

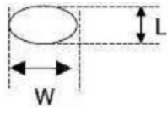
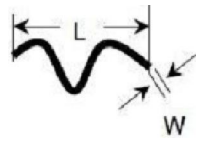
NO.	Defect	Criteria		Remark
		Spec.	Permissible Qty	
1	No display (Major)	Not allowed		
2	Missing line (Major)	Not allowed		
3	Darker or lighter Line (Major)	Not allowed		
4	Weak line(Major)	By limited sample		
5	Bright / Dark point (Minor)	Bright point	1	1:1 sub-pixel: 1R or 1G or 1B 2:Point defect area 1/2 sub pixel.
		Dark point	2	
6	Round type (Minor)	$\phi \leq 0.1\text{mm}$	Disregard	1. $\phi = (W+L)/2$, L:Length,W=Width 2.Disregard if out of A.A 
		$0.1 < \phi \leq 0.2$	3	
		$\phi > 0.2\text{mm}$	0	
	Line type (Minor)	$W \leq 0.03\text{mm}$	Disregard	1. L:Length,W=Width 2.Disregard if out of A.A 
		$L \leq 3.0\text{mm}$ and $0.03\text{mm} < W \leq 0.05\text{mm}$	2	
		$L \leq 3.0\text{mm}$ and $0.05\text{mm} < W \leq 0.1\text{mm}$	1	
		$W > 0.10\text{mm}$ or $L > 3.0\text{mm}$	0	
	Mura (Minor)	By 5% ND filter invisible		

12.3 Others

1. Issues that are not defined in this document shall be discussed and agreed with both parties. (Customer and supplier)
2. Unless otherwise agreed upon in writing, the criteria shall be applied to both parties. (Customer and supplier)

13 Suggestions for using LCD modules

13.1 Handling of LCM

1. The LCD screen is made of glass. Don't give excessive external shock, or drop from a high place.
2. If the LCD screen is damaged and the liquid crystal leaks out, do not lick and swallow. When the liquid is attach to your hand, skin, cloth etc, wash it off by using soap and water thoroughly and immediately.
3. Don't apply excessive force on the surface of the LCM.
4. If the surface is contaminated, clean it with soft cloth. If the LCM is severely contaminated, use Isopropyl alcohol/Ethyl alcohol to clean. Other solvents may damage the polarizer. The following solvents is especially prohibited: water , ketone Aromatic solvents etc.
5. Exercise care to minimize corrosion of the electrode. Corrosion of the electrodes is accelerated by water droplets, moisture condensation or a current flow in a high-humidity environment.
6. Install the LCD Module by using the mounting holes. When mounting the LCD module make sure it is free of twisting, warping and distortion. In particular, do not forcibly pull or bend the I/O cable or the backlight cable.
7. Don't disassemble the LCM.
8. To prevent destruction of the elements by static electricity, be careful to maintain an optimum work environment.
 - Be sure to ground the body when handling the LCD modules.
 - Tools required for assembling, such as soldering irons, must be properly grounded.
 - To reduce the amount of static electricity generated, do not conduct assembling and other work under dry conditions.
 - The LCD module is coated with a film to protect the display surface. Exercise care when peeling off this protective film since static electricity may be generated.
9. Do not alter, modify or change the the shape of the tab on the metal frame.
10. Do not make extra holes on the printed circuit board, modify its shape or change the positions of components to be attached.
11. Do not damage or modify the pattern writing on the printed circuit board.
12. Absolutely do not modify the zebra rubber strip (conductive rubber) or heat seal connector
13. Except for soldering the interface, do not make any alterations or modifications with a soldering iron.
14. Do not drop, bend or twist LCM.

13.2 Storage

1. Store in an ambient temperature of 5 to 45 °C, and in a relative humidity of 40% to 60%. Don't expose to sunlight or fluorescent light.
2. Storage in a clean environment, free from dust, active gas, and solvent.
3. Store in antistatic container.

