

NOTE

Material: Titanium Copper Thickness: 0.12mm

Electroplate:

- Gold Flash on Contact area
- Gold Flash on Solder area
- Nickel underplating over all

Electrical Characteristics:

- Current Voltage: 12V
- Current Rate: 3A
- Contact Resistance: Normal Compression <math>< 30\text{m}\Omega</math>

Working Height of Application: 3.60~5.20mm

Spring Force Tolerance is $\pm 20\text{gf}$

Operating Temperature: $-20^{\circ}\text{C} \sim +85^{\circ}\text{C}$



Place Area NOZZLE

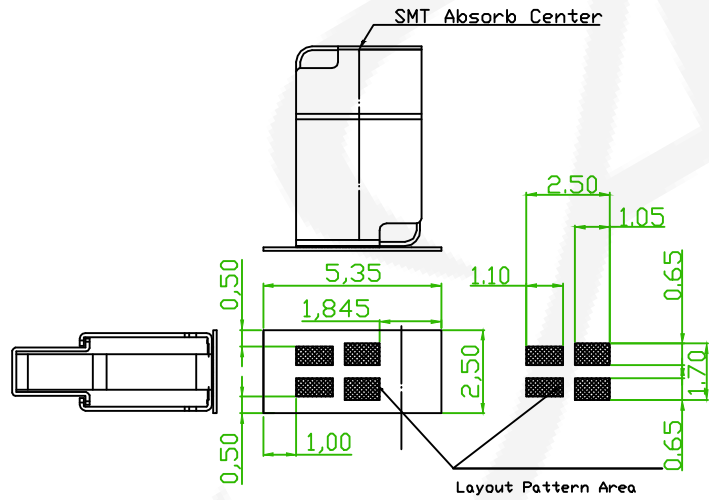
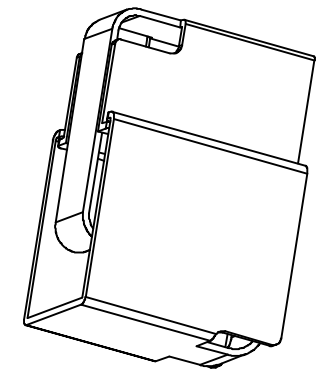
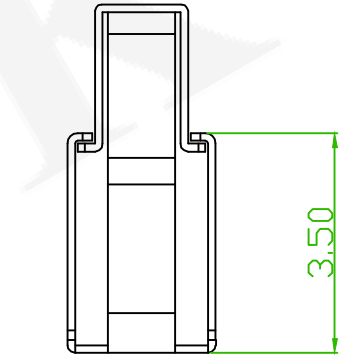
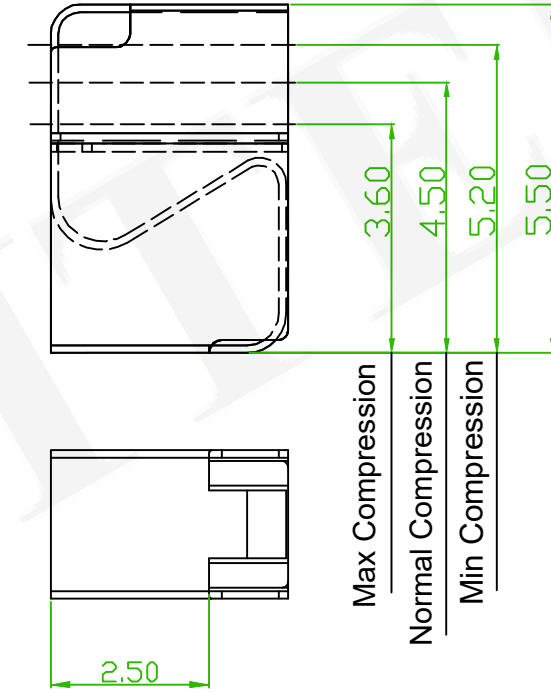
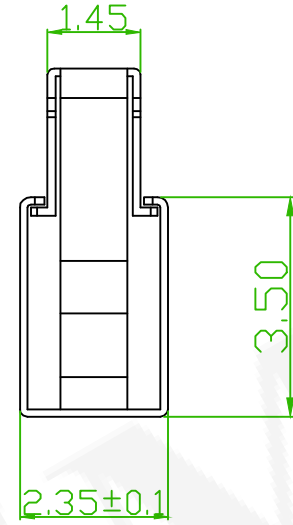
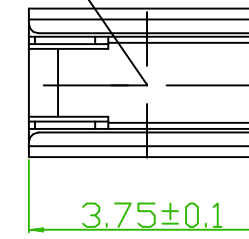

PCB Recommend Layout Pattern

糧德精密有限公司
Amtek Technology Co., Ltd.
TEL: 886-2-2260-6878
FAX: 886-2-2260-8030

| | | | | | | |
|----------------------|----------------------------------|-------------|------|------------------------------|---------------------|-----|
| 品名 TITLE | EMI SPRING | | | | 頁數 Page | 1/1 |
| 品號 PART NO. | 3SST-NN55NN-NNNNG | | | 繪圖 DRAWN | Alice 2022/05/25 | |
| 圖號 DRAWING NO. | GW271-AB331 | 版本 REV. | A | 核對 CHECKED | Josh 2022/05/25 | |
| 客戶品號 CUSTOMER P/N | | 比例 SCALE | None | 承認 APPROVED | Josh 2022/05/25 | |
| 公差 TOLERANCE | X ≤ 30 ±0.2 30 < X ≤ 120 ±0.3 | 單位 UNIT | mm | THIRD ANGLE PROJECTION | | |

| | | | |
|------|------------------------|---------|------|
| REV. | ECN NO. OR DESCRIPTION | REVISED | DATE |
| | | | |