

Ultra Rapid Semiconductor Protection Fuse

European Square Body Type

German Standard Knife Blade
aR Characteristics
Voltage Rating 690V
Current Ratings from 16A to 1000A
Sizes 000, 00, 0, 1, 2 & 3



Key Features:

- ❖ Extremely high interrupting rating fuses for the protection of power semiconductors as per IEC Standard 60269.1 and 4
- ❖ 690V voltage rating complying with IEC 33
- ❖ Non Magnetic construction
- ❖ aR Characteristics (current ratings from 16A to 1000A) as per VDE 636-23 and IEC 269.4
- ❖ All models with double indication visual on the top and integrated trip-indicator
- ❖ Microswitch system reference MS 4L 2-5 B+PRES

Main Characteristics:

Size	Voltage U_N (V)	Ref:	Micro Switch	Current rating I_N (A)	Pre-arcing $I^2t @ 1 \text{ ms}$ I^2t_p (A ² s)	Total Clearing $I^2t @ U_N$ (A ² s)	Power Losses @ 0.8 I_N	Tested Interrupting rating
000	690V	069NHCK0016F	Y	16	10	48	1	80kA @ 690V
		069NHCK0020F	Y	20	15	90	1.5	
		069NHCK0025F	Y	25	22	130	2	
		069NHCK0032F	Y	32	45	270	2.5	
		069NHCK0040F	Y	40	69	400	4	
		069NHCK0050F	Y	50	107	630	5	
		069NHCK0063F	Y	63	220	1300	6	
		069NHCK0080F	Y	80	350	2000	8	
		069NHCK0100F	Y	100	720	4300	9.5	
		069NHCK0125F	Y	125	1400	8200	10.5	
		069NHCK0160F		160	2100	12200	15	
		069NHCK0200F		200	3900	22700	18	
		069NHCK0250F		250	7600	44400	22	
		069NHCK0315F		315	15400	90700	30	

Notes: Minimum operating voltage for integrated trip indicator = 20V

Micro switch reference : MS 4L 2-5B6 

Size	Voltage U_N (V)	Ref:	Micro Switch	Current rating I_N (A)	Pre-arcing $I^2t @ 1 \text{ ms}$ I^2t_p (A ² s)	Total Clearing $I^2t @ U_N$ (A ² s)	Power Losses @ 0.8 I_N	Tested Interrupting rating
00	690V	069NHDK0020F	Y	20	15	90	1.5	170kA @ 690V
		069NHDK0025F	Y	25	22	130	2	
		069NHDK0032F	Y	32	45	270	2.5	
		069NHDK0040F	Y	40	69	400	4	
		069NHDK0050F	Y	50	110	630	5	
		069NHDK0063F	Y	63	220	1300	6	
		069NHDK0080F	Y	80	350	2000	8	
		069NHDK0100F	Y	100	720	4300	8.5	
		069NHDK0125F	Y	125	1390	8200	10	
		069NHDK0160F	Y	160	2100	12200	14	
		069NHDK0200F	Y	200	3900	22700	17	
		069NHDK0250F	Y	250	7600	44400	20	
		069NHDK0315F	Y	315	15400	90700	29	

Notes: Minimum operating voltage for integrated trip indicator = 20V

Micro switch reference : MS 4L 2-5B6 

Size	Voltage U_N (V)	Ref:	Micro Switch	Current rating I_N (A)	Pre-arcing $I^2t @ 1 \text{ ms}$ I^2t_p (A ² s)	Total Clearing $I^2t @ U_N$ (A ² s)	Power Losses @ 0.8 I_N	Tested Interrupting rating
0	690V	069NH0K0032F	Y	32	32	170	9.5	170kA @ 690V
		069NH0K0040F	Y	40	53	280	10	
		069NH0K0050F	Y	50	87	470	10.5	
		069NH0K0063F	Y	63	130	700	11.5	
		069NH0K0080F	Y	80	180	970	12.5	
		069NH0K0100F	Y	100	390	2080	15	
		069NH0K0125F	Y	125	720	3890	18	
		069NH0K0160F	Y	160	1550	8320	22	
		069NH0K0200F	Y	200	2950	15900	27	
		069NH0K0250F	Y	250	5560	29900	33	
		069NH0K0315F		315	11600	62300	40	

Notes: Minimum operating voltage for integrated trip indicator = 20V.

Micro switch reference : MS 4L 2-5B6 

Size	Voltage U_N (V)	Ref:	Micro Switch	Current rating I_N (A)	Pre-arcing $I^2t @ 1 \text{ ms}$ I^2t_p (A ² s)	Total Clearing $I^2t @ U_N$ (A ² s)	Power Losses @ 0.8 I_N	Tested Interrupting rating
1	690V	069NH1K0063F	Y	63	130	700	18	170kA @ 690V
		069NH1K0080F	Y	80	220	1170	21,5	
		069NH1K0100F	Y	100	290	1570	23	
		069NH1K0125F	Y	125	620	3320	26	
		069NH1K0160F	Y	160	1170	6270	29	
		069NH1K0200F	Y	200	2470	13300	33	
		069NH1K0250F	Y	250	4670	25100	37	
		069NH1K0315F	Y	315	9570	51400	42	
		069NH1K0350F	Y	350	13400	72300	44	
		069NH1K0400F	Y	400	19500	105000	48	

Notes: Minimum operating voltage for integrated trip indicator = 20V.

Micro switch reference : MS 4L 2-5B6 

Size	Voltage U_N (V)	Ref:	Micro Switch	Current rating I_N (A)	Pre-arcing $I^2t @ 1 \text{ ms}$ $I^2t_p(A^2s)$	Total Clearing $I^2t @ U_N$ (A ² s)	Power Losses @ 0.8 I_N	Tested Interrupting rating
2	690V	069NH2K0160F	Y	160	960	5180	38	170kA @ 690V
		069NH2K0200F	Y	200	1710	9220	42	
		069NH2K0250F	Y	250	3480	18700	46.5	
		069NH2K0315F	Y	315	6860	36900	54	
		069NH2K0350F	Y	350	9570	51400	58	
		069NH2K0400F	Y	400	13400	72300	62.5	
		069NH2K0450F	Y	450	21000	113000	69	
		069NH2K0500F	Y	500	27400	147000	73	
		069NH2K0550F	Y	560	38300	206000	78	
		069NH2K0630F	Y	630	58700	315000	85	
		069NH2K0700F		700	78100	420000	87	

Notes: Minimum operating voltage for integrated trip indicator = 20V.

Micro switch reference : MS 4L 2-5B6 

Size	Voltage U_N (V)	Ref:	Micro Switch	Current rating I_N (A)	Pre-arcing $I^2t @ 1 \text{ ms}$ $I^2t_p(A^2s)$	Total Clearing $I^2t @ U_N$ (A ² s)	Power Losses @ 0.8 I_N	Tested Interrupting rating
3	690V	069NH3K0315F	Y	315	5251	28200	57	170kA @ 690V
		069NH3K0350F	Y	350	7562	40600	58	
		069NH3K0400F	Y	400	10500	56500	65.5	
		069NH3K0450F	Y	450	15700	84300	70	
		069NH3K0500F	Y	500	22200	119000	75	
		069NH3K0550F	Y	560	30200	163000	80	
		069NH3K0630F	Y	630	42000	226000	89	
		069NH3K0700F	Y	700	61700	332000	100	
		069NH3K0800F	Y	800	88900	478000	112	
		069NH3K0900F	Y	900	123900	666000	125	
		069NH3K1000F		1000	178400	959000	140	

Notes: Minimum operating voltage for integrated trip indicator = 20V.

Micro switch reference : MS 4L 2-5B6 

Electrical Characteristics:

Times vs current characteristics

The following curves and those on page 6 indicate, for each rated current, pre-arcing time as a function of RMS value of pre-arcing current I.

Tolerance for mean pre-arcing current:

±10% = ratings from (to be confirmed)

± 8% = ratings from (to be confirmed)

They do not show a minimum breaking capacity but limit currents of non-operation or operation in compliance with standard VDE 636/23.

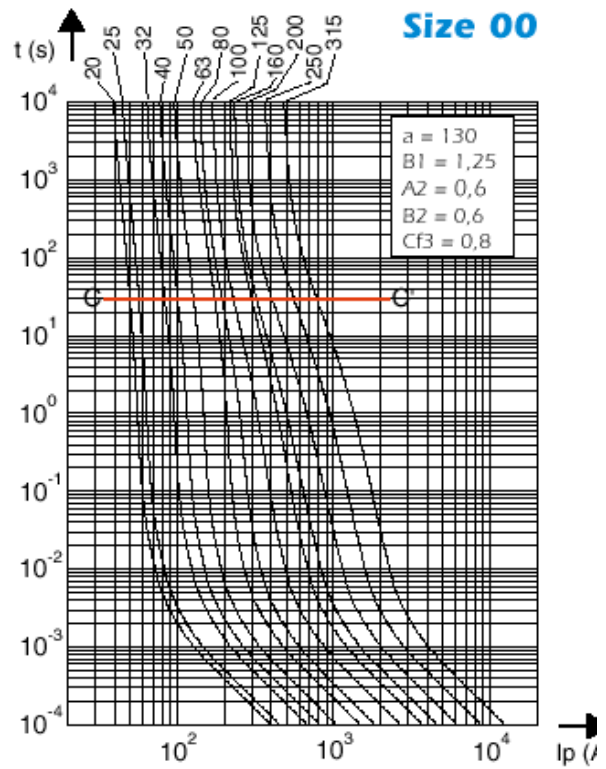
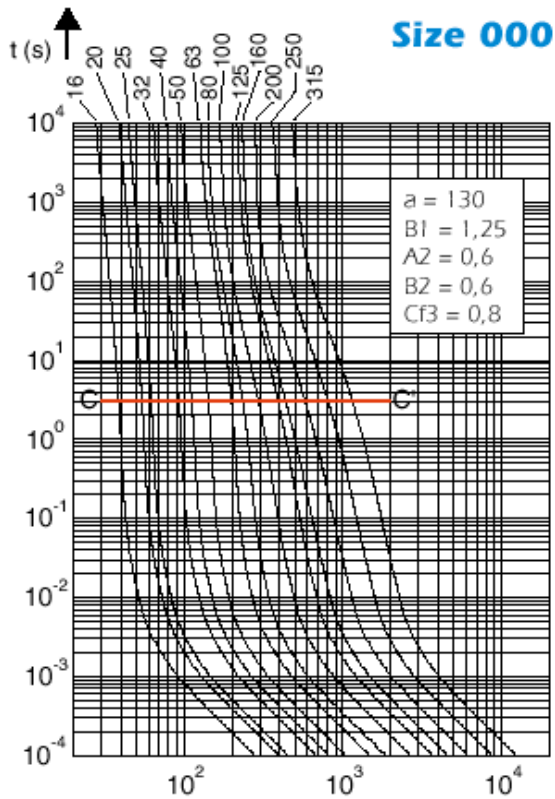

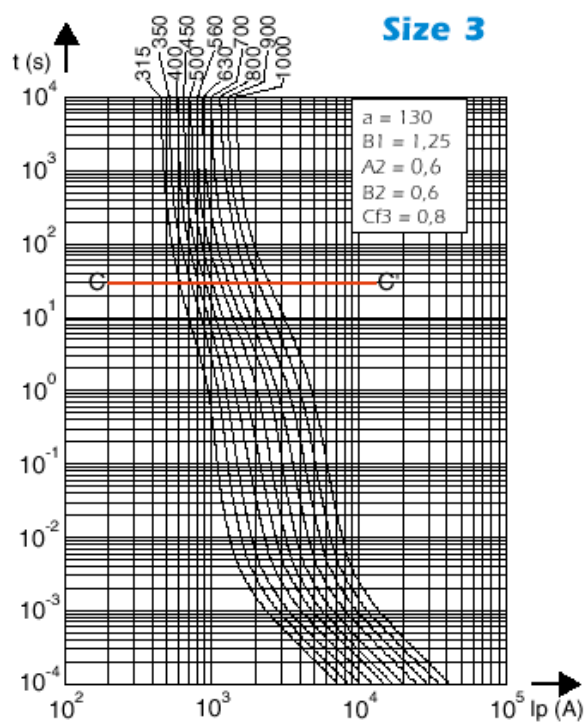
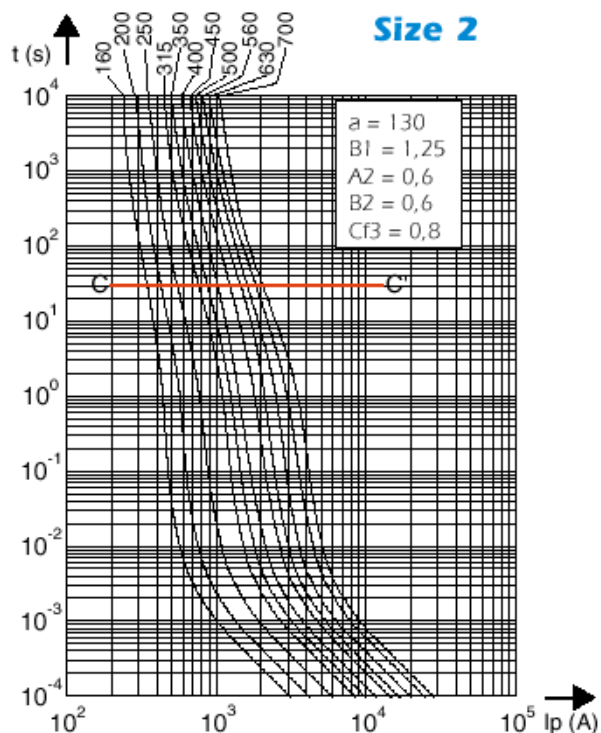
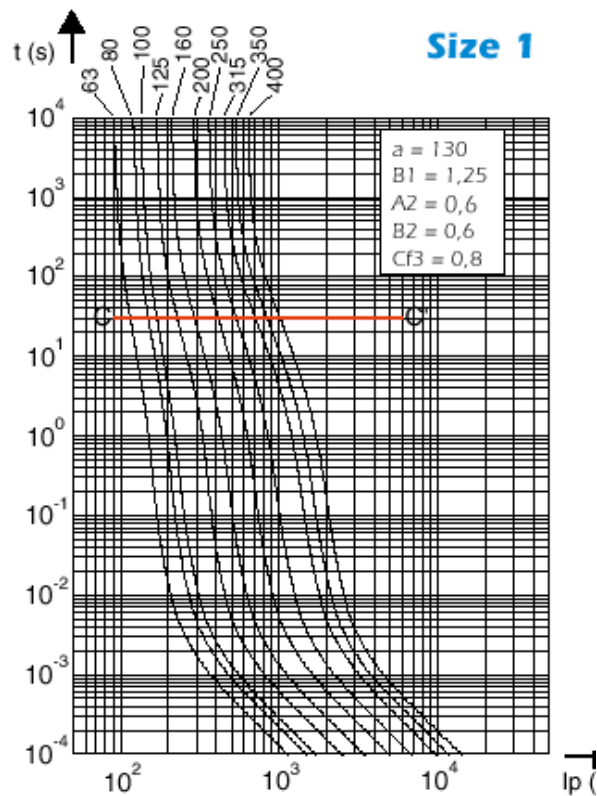
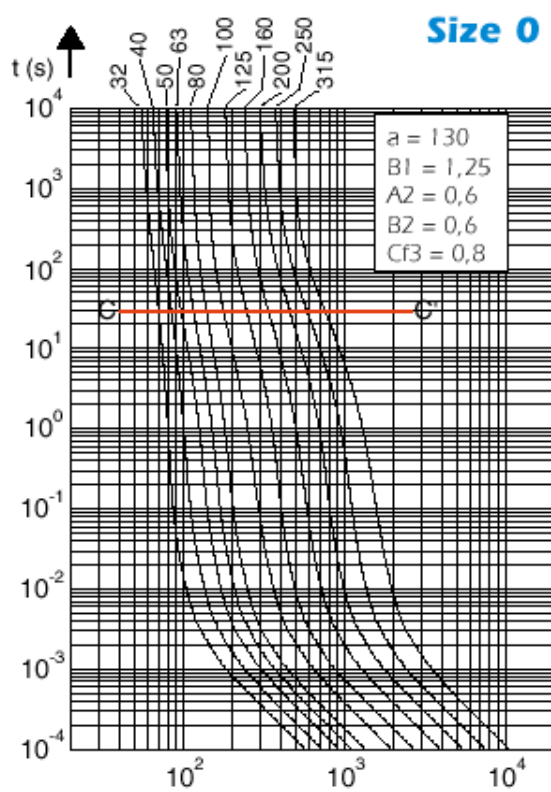

Total clearing I²T:

Horizontal curve shows maximum values of total clearing I²t (I²t_t) for each rated current as a function of prospective current I_p @ 690V cos φ = 0.15. Oblique lines indicate total clearing duration T_t, with associated pre-arcing duration in brackets.

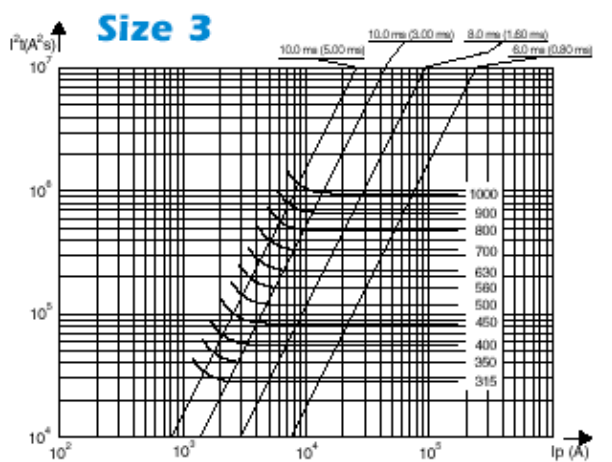
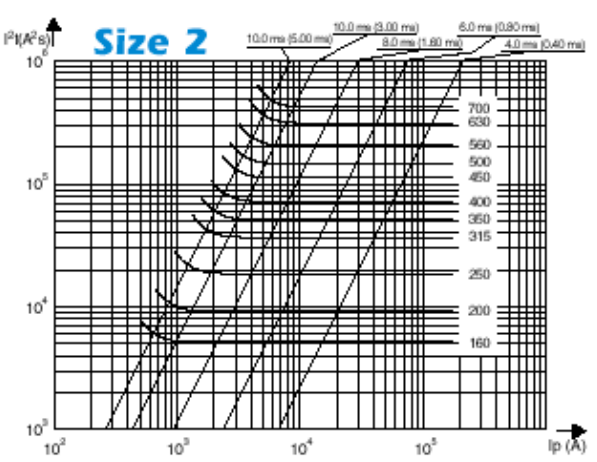
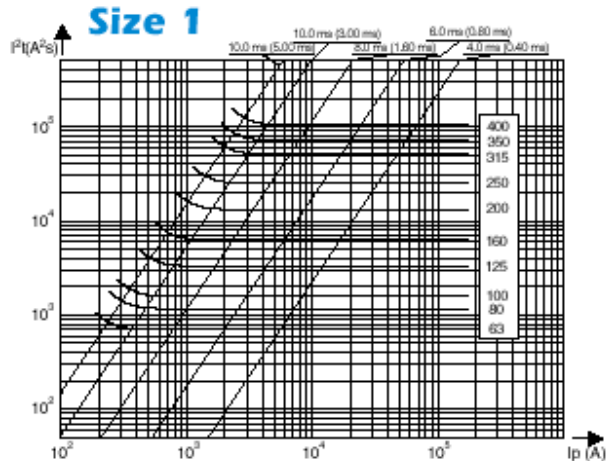
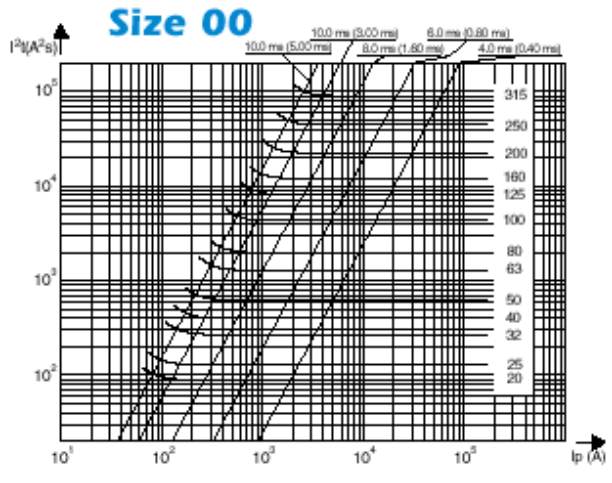
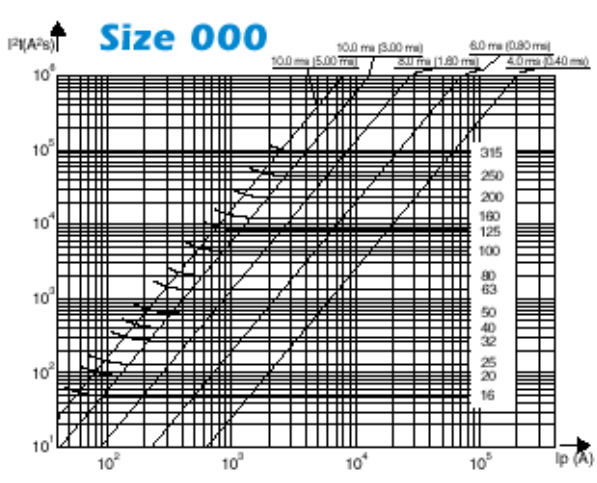

Cut off Characteristics:

The curve above shows, for each rating, value of peak let-through current I_C as a function of available fault current I_p .

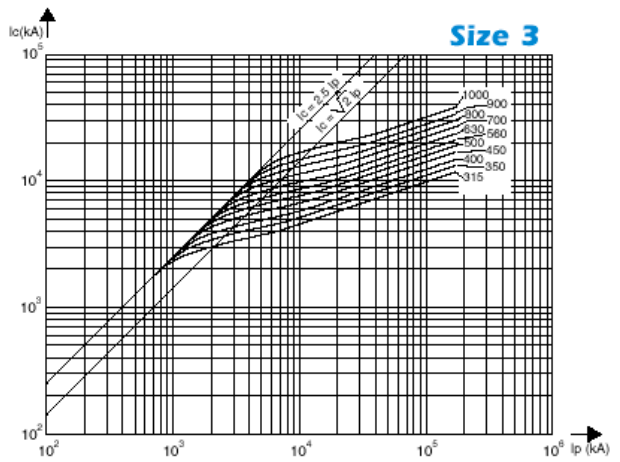
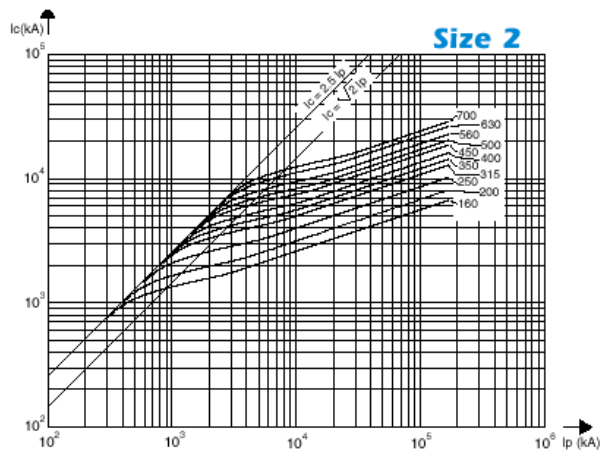
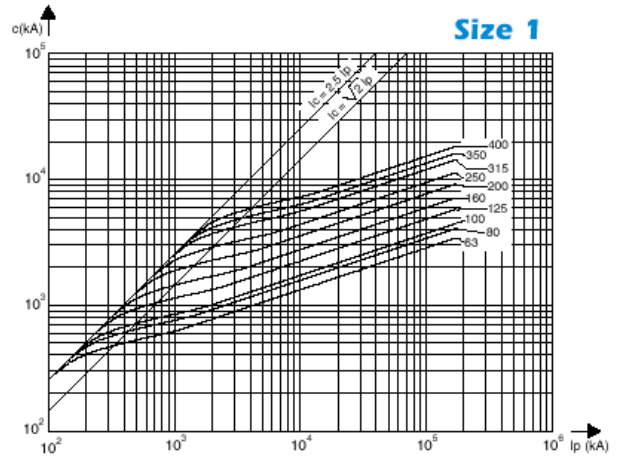
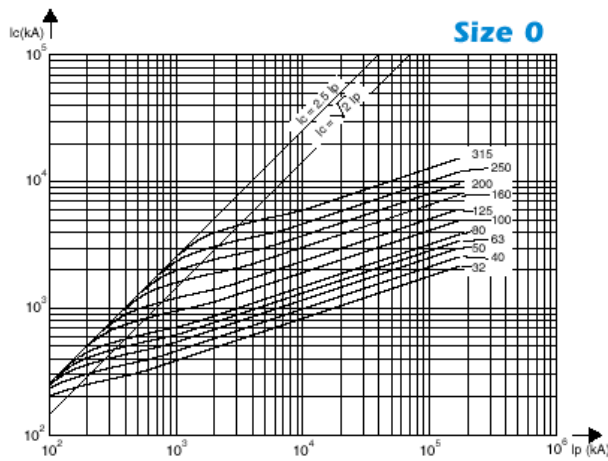
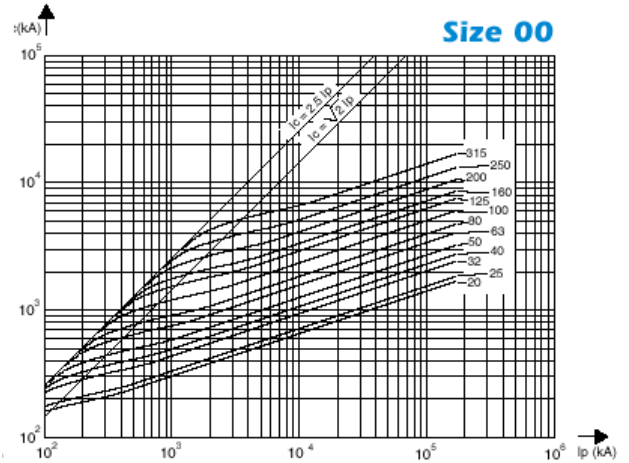
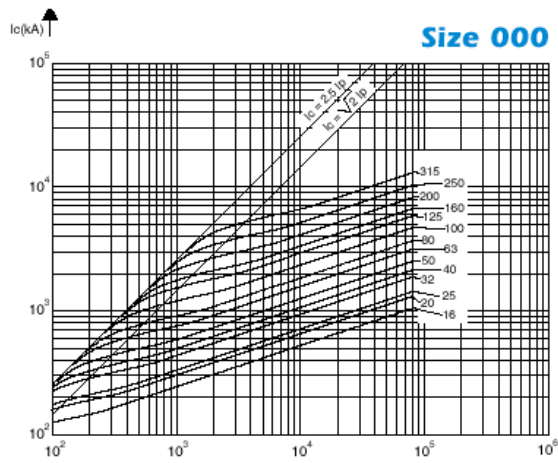

I²t Multiplier Coefficient

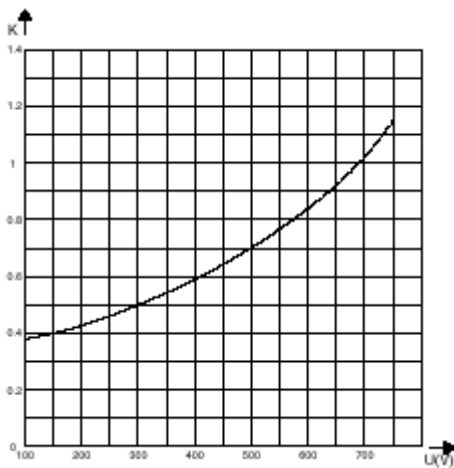

Mean curves showing variation of total clearing time (I^2t_t) and total clearing duration T_t as a function of operating voltage U .

Peak arc voltage

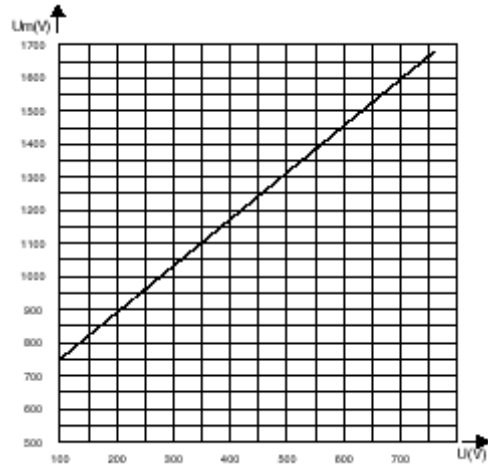

Curves showing peak value U_m of arc voltage which appears across fuse-link as a function of operating voltage U @ $\cos\phi = 0.15$

Dissipated Power

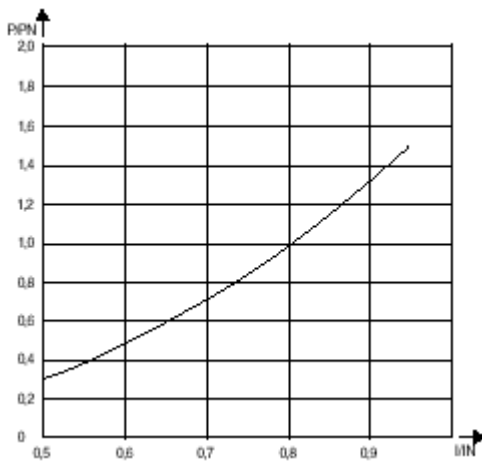

Curve enabling calculation of dissipated power P by a fuse rated I_N , as a function of the RMS current I , in multiples of I_N in a steady state.

Outline Drawing & Ordering Information:

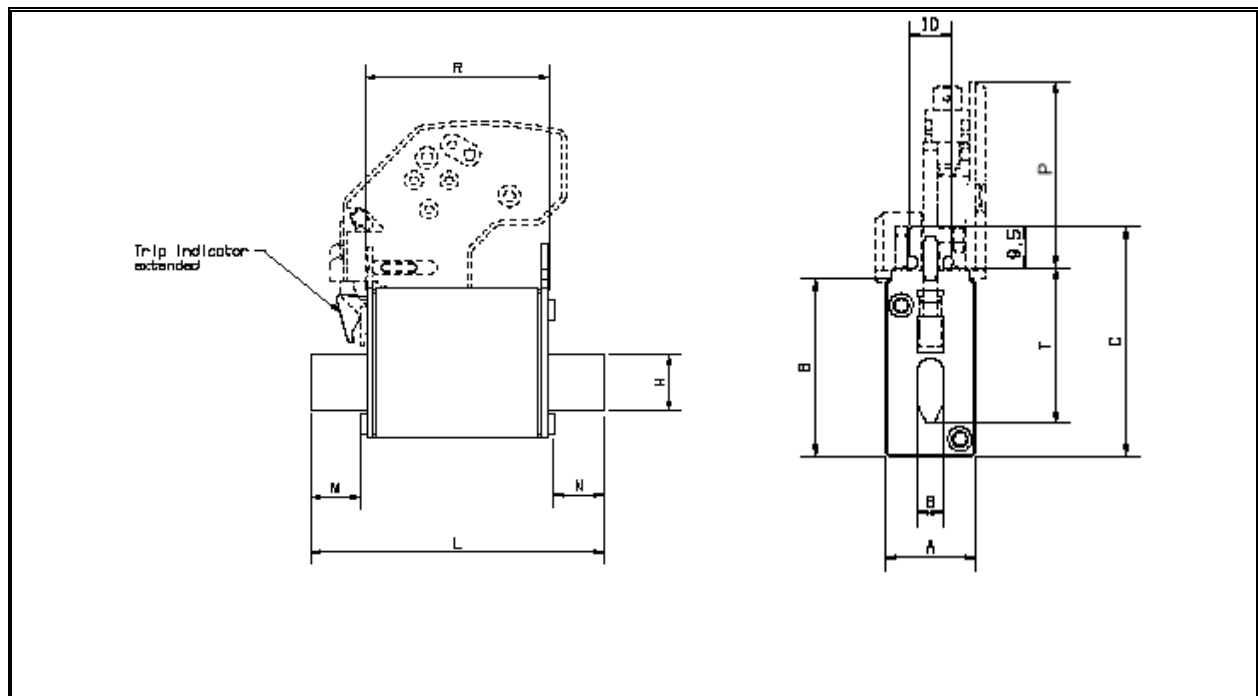

Size	A	B	C	H	L	M	N	P	R	T	Weight
000	20.8	40.5	52.5	15	79	13.5	13.5	43.4	49.5	35	135gm
00	29.5	47.5	59.5	15	79	13.1	13.1	43.4	50	35	200gm
0	29.5	47.5	59.5	15	125	29.1	29.1	43.4	66	35	250gm
1	39.5	52.5	64.5	20	135	32.1	32.1	43.4	68	40	430gm
2	51	60	72	26	150	38.85	38.85	43.4	68	48	600gm
3	70	74	86	33	150	38.85	38.85	43.4	68	60	750gm

ORDERING INFORMATION

(Please quote code as below)

Voltage Rating (V)	Type	Size	Fixing	Current Rating (A)	Trip (Tag) Indicator
690	NH	000 "C", 00 "D", 0, 1, 2, 3	K	0016 - 1000	F

Order code: e.g. **069NHCK0200F** = 690V European Square body, size 000, knife blade, 200Amps with flap type indicator.

IXYS Semiconductor GmbH
 Edisonstraße 15
 D-68623 Lampertheim
 Tel: +49 6206 503-0
 Fax: +49 6206 503-627
 E-mail: marcom@ixys.de



An IXYS Company

Westcode Semiconductors Ltd
 Langley Park Way Langley Park
 Chippenham Wiltshire SN15 1GE
 Tel: +44 (0)1249 444524
 Fax: +44 (0)1249 659448
 E-mail: WSL.sales@westcode.com

IXYS Corporation
 3540 Bassett Street
 Santa Clara CA 95054 USA
 Tel: +1 (408) 982 0700
 Fax: +1 (408) 496 0670
 E-mail: sales@ixys.com

www.westcode.com

www.ixys.com

Westcode Semiconductors Inc
 3270 Cherry Avenue
 Long Beach CA 90807 USA
 Tel: +1 (562) 595 6971
 Fax: +1 (562) 595 8182
 E-mail: WSI.sales@westcode.com

The information contained herein is confidential and is protected by Copyright. The information may not be used or disclosed except with the written permission of and in the manner permitted by the proprietors Westcode Semiconductors Ltd.

© Westcode Semiconductors Ltd.

In the interest of product improvement, Westcode reserves the right to change specifications at any time without prior notice.