

LAN9303 PHY Daughter Board Information Sheet

The LAN9303 PHY Daughter Board (AC320004-4) enables Ethernet communication with a variety of Microchip starter kits. For more information, please visit: <http://www.microchip.com>. From the Design Support menu, click **Development Tools**. Then, from the Starter Kits menu, click **MPLAB Starter Kit**, and then select the desired starter kit.

Schematics

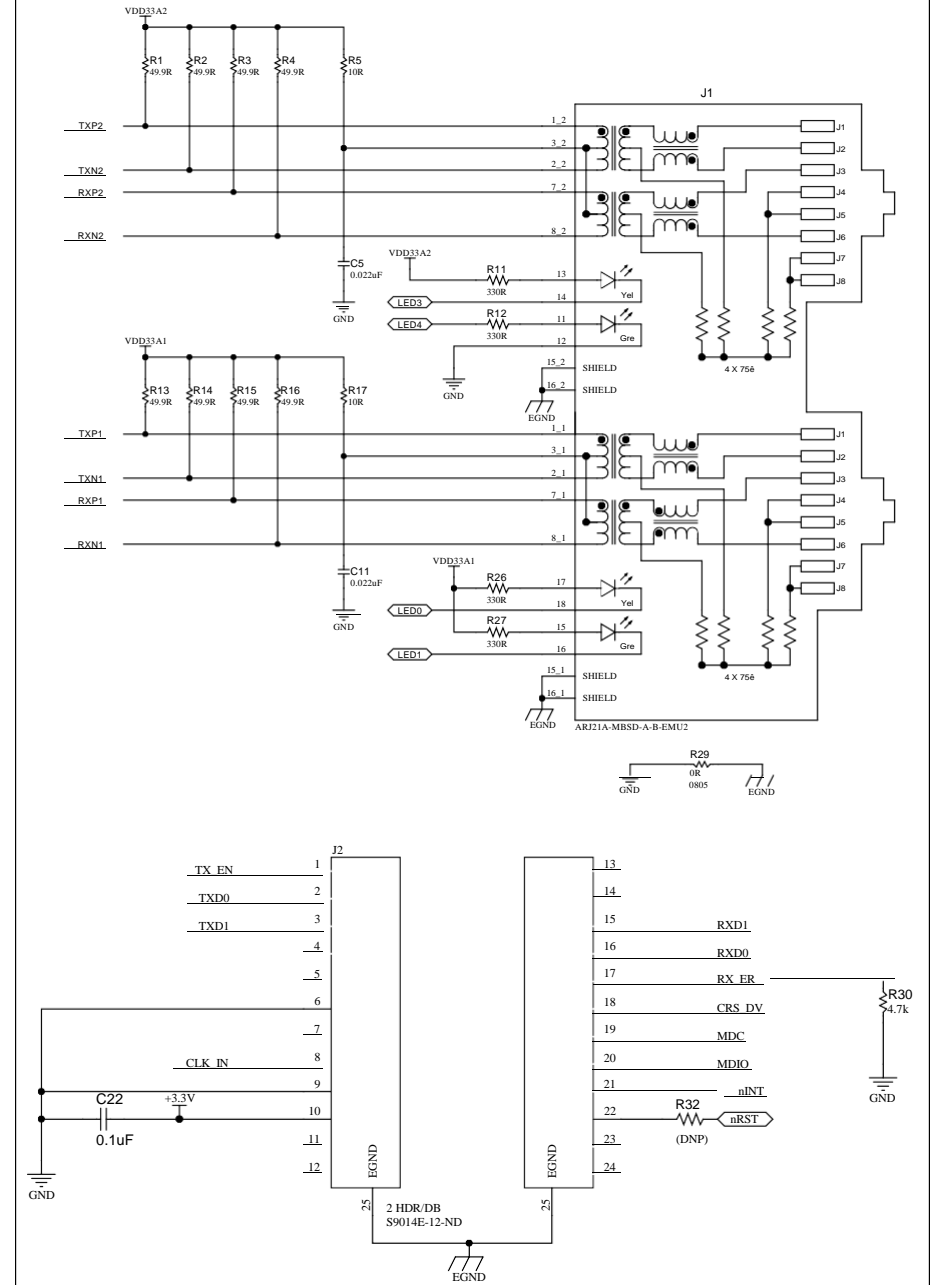

03/25/14

Americas

- Atlanta - 678-957-9614
- Austin - 512-257-3370
- Boston - 774-760-0087
- Chicago - 630-285-0071
- Cleveland - 216-447-0464
- Dallas - 972-818-7423
- Detroit - 248-848-4000
- Houston - 281-894-5983
- Indianapolis - 317-773-8323
- Los Angeles - 949-462-9523
- New York - 631-435-6000
- Phoenix - 480-792-7200
- Santa Clara - 408-961-6444
- Toronto - 905-673-0699

Europe

- Austria - Wels - 43-7242-2244-39
- Denmark - Copenhagen - 45-4450-2828
- France - Paris - 33-1-69-53-63-20
- Germany - Munich - 49-89-627-144-0
- Italy - Milan - 39-0331-742611
- Netherlands - Drunen - 31-416-690399
- Spain - Madrid - 34-91-708-08-90
- UK - Wokingham - 44-118-921-5869

Asia/Pacific

- Australia - Sydney - 61-2-9868-6733
- China - Beijing - 86-10-8569-2100

Asia/Pacific (Continued)

- China - Chengdu - 86-28-8665-5511
- China - Chongqing - 86-23-8980-9588
- China - Hangzhou - 86-571-8792-8115
- China - Hong Kong SAR - 852-2943-5100
- China - Nanjing - 86-25-8473-2460
- China - Qingdao - 86-532-8502-7355
- China - Shanghai - 86-21-5407-5533
- China - Shenyang - 86-24-2334-2829
- China - Shenzhen - 86-755-8864-2200
- China - Wuhan - 86-27-5980-5300
- China - Xiamen - 86-592-2388138
- China - Xian - 86-29-8833-7252
- China - Zhuhai - 86-756-3210040
- India - Bangalore - 91-80-3090-4444
- India - New Delhi - 91-11-4160-8631
- India - Pune - 91-20-3019-1500
- Japan - Osaka - 81-6-6152-7160
- Japan - Tokyo - 81-3-6880-3770
- Korea - Daegu - 82-53-744-4301
- Korea - Seoul - 82-2-554-7200
- Malaysia - Kuala Lumpur - 60-3-6201-9857
- Malaysia - Penang - 60-4-227-8870
- Philippines - Manila - 63-2-634-9065
- Singapore - 65-6334-8870
- Taiwan - Hsin Chu - 886-3-5778-366
- Taiwan - Kaohsiung - 886-7-213-7840
- Taiwan - Taipei - 886-2-2508-8600
- Thailand - Bangkok - 66-2-694-1351



Microchip Technology Inc. • 2355 West Chandler Blvd. • Chandler, AZ 85224-6199

www.microchip.com

The Microchip name and logo, the Microchip logo, and MPLAB are registered trademarks of Microchip Technology Incorporated in the U.S.A. and other countries. All other trademarks mentioned herein are property of their respective companies. © 2014, Microchip Technology Incorporated, Printed in the U.S.A. All Rights Reserved. 03/14

DS50002276A



LAN9303 PHY Daughter Board Information Sheet

Schematics (Continued)

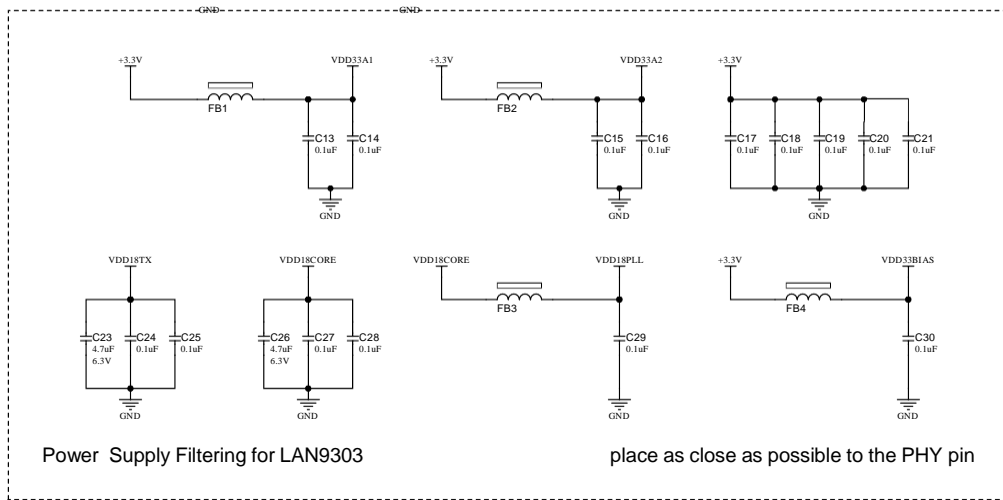
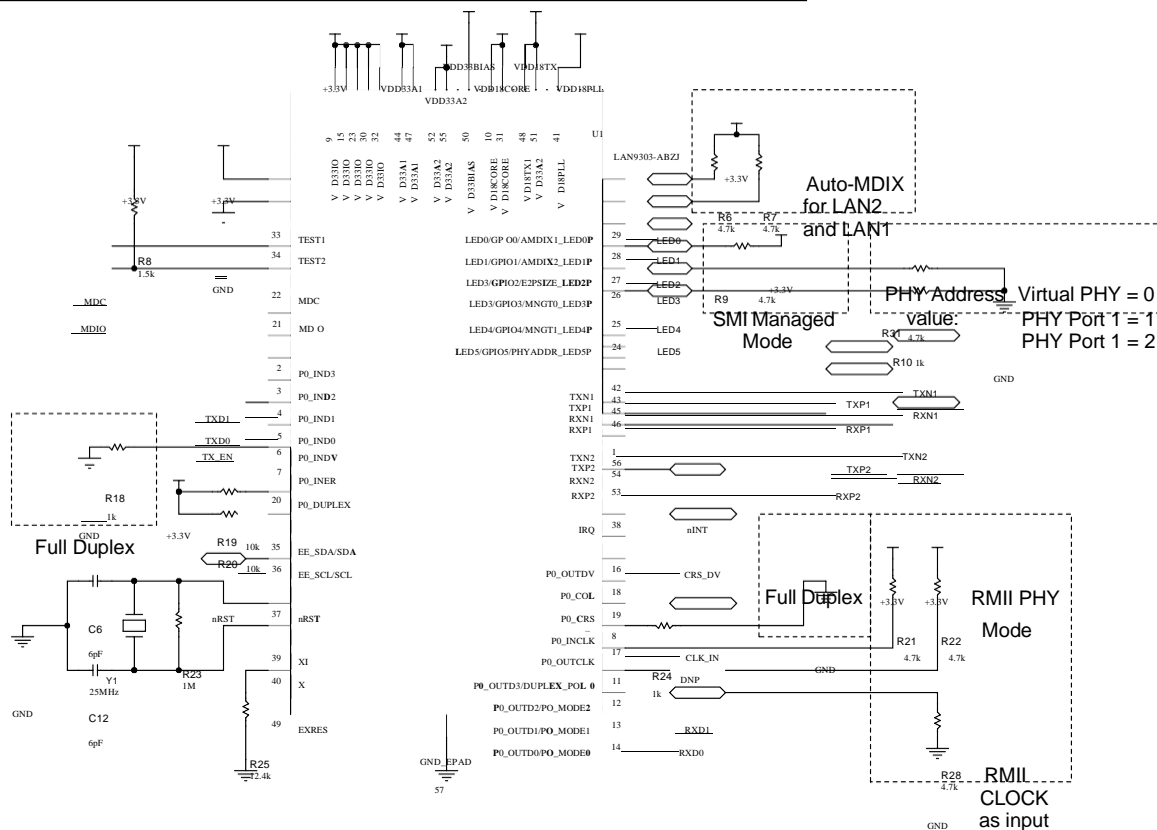

Classification: **GenelPublic**