

SPECIFICATION FOR APPROVAL

CUSTOMER :	DATE :
PART NO : LFU09V-501	DWG.NO : TD1250101
CUSTOMER PART NO :	CUST.DWG.NO :

(1) UNIT: mm

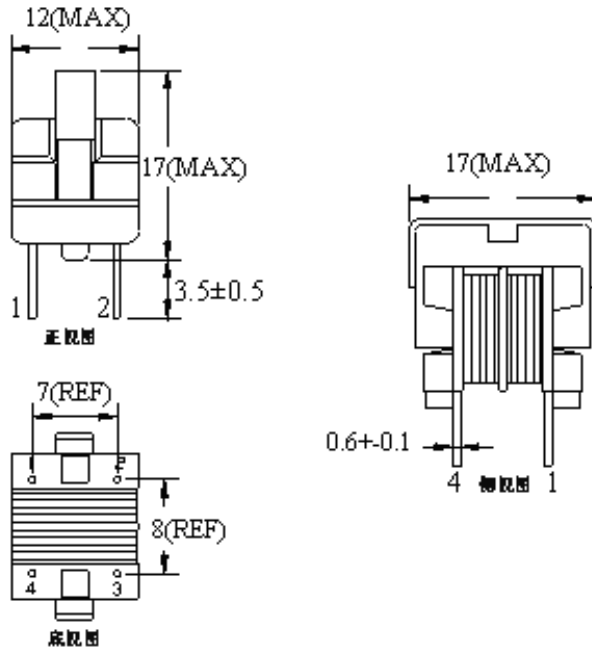

(2) SCHEMATIC

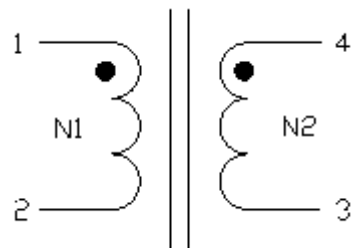

DRAWN BY AMY	CHECKED BY 張明德	APPROVED BY 吳載敏
-----------------	-------------------	--------------------

SPECIFICATION FOR APPROVAL

CUSTOMER :		DATE :	
PART NO : LFU09V-501		DWG.NO : TD1250101	
CUSTOMER PART NO :		CUST.DWG.NO :	
PARAMETER	TERMINAL	SPECIFICATION	TEST INSTRUMENTS
INDUCTANCE	L (1-2)=(4-3)	0.5mH (MIN)	1KHz/0.25V
DCR:	DCR (1-2)=(4-3)	0.12Ω (MAX)	
IDC	IDC (1-2)=(4-3)	1.0A (MAX)	
HI-POT	PIN1-PIN4	AC 1.0KV/5mA/1SEC	
	PIN1,4-CORE	AC 0.5KV/5mA/1SEC	
MATERIAL	SPEC	SUPPLIER	REMARK
CORE	UU9.8 R10K	VAKOS	
WIRE	2UEW φ 0.35 NTL 130°C	TAI-I	
WINDING	25TS(REF)		
BOBBIN	UU9.8 PLENOLIC T375J	CHANGCHUN	
DRAWN BY AMY		CHECKED BY 張明德	APPROVED BY 吳載敏

CORE MASTER ENTERPRISE CO., LTD.

TEL:886-2-8919-1288 FAX:886-2-8919-1298 WEB:www.coremaster.com.tw

SPECIFICATION FOR APPROVAL

CUSTOMER :			DATE :		
PART NO : LFU09V-501			DWG.NO : TD1250101		
CUSTOMER PART NO :			CUST.DWG.NO :		
繞組	START	END	WIRE SIZE	TURNS(TS)	TAPE(TS)
N1	1	2	ϕ 0.35×1P	25(REF)	
N2	4	3	ϕ 0.35×1P	25(REF)	
DRAWN BY AMY			CHECKED BY 張明德		APPROVED BY 吳載敏

CORE MASTER ENTERPRISE CO., LTD.

TEL:886-2-8919-1288 FAX:886-2-8919-1298 WEB:www.coremaster.com.tw