

Classification: Kurum İçi Restricted

Wio-WM1302 Long Range Gateway Module(SPI) - EU868

WM1302 module is a new generation of Long Range gateway module in mini-PCIe form-factor based on Semtech® SX1302. It features extremely low power consumption, outstanding performance with CE, FCC, Telec certified.



Features

Powered by Semtech® SX1302 baseband LoRa® chip, extremely low power consumption and high performance.

Mini-PCIe form factor with the standard 52-pin golden finger, easy to integrate with various gateway devices.

Ultra-low operating temperature, no additional heat dissipation needed, reducing the size of LoRaWAN gateway.

High sensitivity down to -139 dBm @SF12 with SX1250 TX/RX front-end; TX power up to 26 dBm @3.3V.

Certified with CE(EU868), FCC ID(US915), and TELEC(AS923). Simplify the final product certification process.

WM1302 module is a new generation of LoRaWAN gateway module with mini-PCIe form-factor. Based on the Semtech® SX1302 baseband LoRaWAN® chip, WM1302 unlocks the greater potential capacity of long-range wireless transmission for gateway products. It features higher sensitivity, less power consumption, and lower operating temperature than the previous SX1301 and SX1308 LoRa® chips.

WM1302 LoRaWAN gateway module has SPI and USB versions on both US915 and EU868 frequency bands, enabling you to have a wide-range of LoRaWAN frequency plans options to choose including EU868, US915, AS923, AS920, AU915, KR920, and IN865.

The WM1302 module has passed various certifications such as CE (EU868), FCC ID (US915), TELEC (AS923). These help to simplify the development and certification process of long range gateway devices.

WM1302 is designed for M2M and IoT applications and can be widely applied in LPWAN gateway supported scenarios. It would be a perfect choice for you to significantly reduce the technical difficulties and time-consumption when developing the LoRa gateway devices, including LoRaWAN gateway, etc.

Classification: Kurum İçi Restricted

Hardware Overview

Diagram

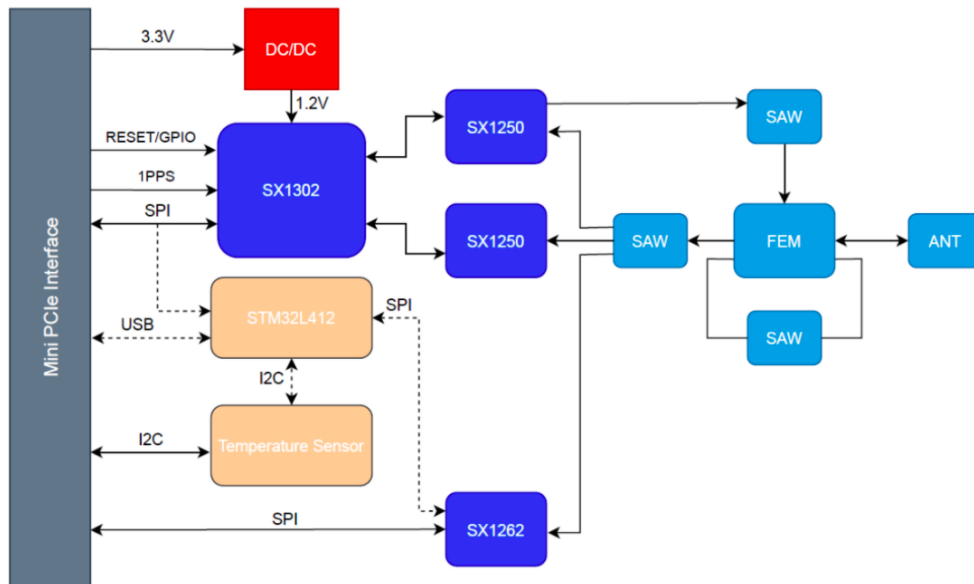

Pinout



WM1302 LoRaWAN Gateway Module (SPI / USB)



- DI - Digital Input
 ■ DO - Digital Output
 ■ DIO - Bidirectional
 ■ NC - No Connection
- PO - Power
 ■ GND - Ground
 ■ SPI
 ■ IIC
- 🍷 GPIO connected to Raspberry Pi
🌡️ Temperature Sensor

Classification: Kurum İçi Restricted

No.	Mini PCIe Pin	WM1302 Pin	IO type	Function
1	WAKE#	NC		
2	3.3Vaux	3V3	Power	
3	COEX1	NC		
4	GND	GND	Ground	
5	COEX2	NC		
6	1.5 V	NC		
7	CLKREQ#	NC		
8	UIM_PWR	SX1262_BUSY	DO	SX1262 BUSY Pin
9	GND	GND	Ground	
10	UIM_DATA	SX1262_RST	DI	SX1262 Reset Pin
11	REFCLK-	NC		
12	UIM_CLK	NC		
13	REFCLK+	NC		
14	NIM_RESET	I2C_SCL	DI	Temperature Sensor I2C Clock
15	GND	GND	Ground	
16	UIM_VPP	I2C_SDA	DIO	Temperature Sensor I2C Data
17	Reserved	NC		
18	GND	GND	Ground	
19	Reserved	1PPS	DI	GPS 1PPS
20	W_DISABLE#	NC		
21	GND	GND		
22	PERST#	RESET	DI	SPI version: Active HIGH; USB version: Active LOW
23	PERn0	NC		
24	3.3Vaux	3V3	Power	
25	PERp0	SX1262_CSN	DI	SX1262 Chip Select
26	GND	GND	Ground	
27	GND	GND	Ground	
28	1.5V	NC		
29	GND	GND	Ground	
30	SMB_CLK	I2C_SCL	DI	Temperature Sensor I2C Clock
31	PETn0	SX1262_IO2	DIO	SX1262 DIO2 Pin
32	SMB_DATA	I2C_SDA	DIO	Temperature Sensor I2C Data
33	PETp0	SX1262_IO1	DIO	SX1262 DIO1 Pin
34	GND	GND	Ground	
35	GND	GND	Ground	
36	USB_D-	USB_D-	DIO	USB differential data -
37	GND	GND	Ground	
38	USB_D+	USB_D+	DIO	USB differential data +
39	3.3Vaux	3V3	Power	
40	GND	GND	Ground	
41	3.3Vaux	3V3	Power	
42	LED_WWAN#	NC		
43	GND	GND	Ground	
44	LED_WLAN#	NC		
45	Reserved	SPI_SCK	DI	SPI Clock
46	LED_WPAN#	NC		
47	Reserved	SPI_MISO	DO	SPI MISO
48	1.5V	NC		
49	Reserved	SPI_MOSI	DI	SPI MOSI
50	GND	GND	Ground	
51	Reserved	SX1302_CSN	DI	SX1302 Chip select
52	3.3Vaux	3V3	Power	

Applications

- LPWAN Gateway devices development
- Any long-distance wireless communication application development
- LoRa and LoRaWAN application learn and research

Classification: Kurum İçi Restricted

Specifications

Region	EU868	US915
Frequency	863-870MHz	902-928MHz
Sensitivity	-125dBm @125K/SF7 -139dBm @125K/SF12	-125dBm @125K/SF7 -139dBm @125K/SF12
TX Power	26 dBm (with 3.3V power supply)	25 dBm (with 3.3V power supply)
LEDs	Power: Green Config: Red TX: Green RX: Blue	
Form Factor	Mini PCIe, 52pin Golden Finger	
Power Consumption (SPI version)	Standby: 7.5 mA TX maximum power: 415 mA RX: 40 mA	
Power Consumption (USB version)	Standby: 20 mA TX maximum power: 425 mA RX: 53 mA	
LBT(Listen Before Talk)	Support	
Antenna Connector	U.FL	
Operating Temperature	-40°C to 85°C	
Dimensions	30 mm (width) × 50.95 mm (length)	
Certification	CE (EU868), FCC ID (US915), TELEC (AS923)	

Dimension

