

SEED-110991188

Speed M1w Dock Suit Eval Brd

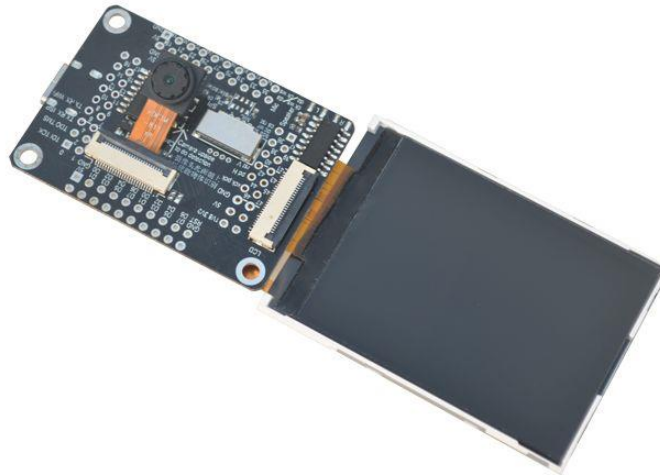

PRODUCT DETAILS

MAIX's Advantage and Usage Scenarios:

- MAIX is not only hardware, but also provide an end-to-end, hardware + software infrastructure for facilitating the deployment of customers' AI-based solutions.
- Thanks to its performance, small footprint, low power, and low cost, MAIX enables the broad deployment of high-quality AI at the edge.
- MAIX isn't just a hardware solution, it combines custom hardware, open software, and state-of-the-art AI algorithms to provide high-quality, easy to deploy AI solutions for the edge.
- MAIX can be used for a growing number of industrial use-cases such as predictive maintenance, anomaly detection, machine vision, robotics, voice recognition, and many more. It can be used in manufacturing, on-premise, healthcare, retail, smart spaces, transportation, etc.

MAix's CPU

- In hardware, MAIX have powerful KPU K210 inside, it offers many excited features:
- 1st competitive RISC-V chip, also 1st competitive AI chip, newly release in Sep. 2018
- 28nm process, dual-core RISC-V 64bit IMAFDC, on-chip huge 8MB high-speed SRAM (not for XMR :D), 400MHz frequency (able to 800MHz)
- KPU (Neural Network Processor) inside, 64 KPU which is 576bit width, support convolution kernels, any form of activation function. It offers 0.25TOPS@0.3W,400MHz, when overclock to 800MHz, it offers 0.5TOPS. It means you can do object recognition 60fps@VGA
- APU (Audio Processor) inside, support 8mics, up to 192KHz sample rate, hardcore FFT unit inside, easy to make a Mic Array (MAIX offer it too)
- Flexible FPIOA (Field Programmable IO Array), you can map 255 functions to all 48 GPIOs on the chip
- DVP camera and MCU LCD interface, you can connect an DVP camera, run your algorithm, and display on LCD
- Many other accelerators and peripherals: AES Accelerator, SHA256 Accelerator, FFT Accelerator (not APU's one), OTP, UART, WDT, IIC, SPI, I2S, TIMER, RTC, PWM, etc.

MAix's Module

Inherit the advantage of K210's small footprint, Sipeed MAIX-I module, or called M1, integrate K210, 3-channel DC-DC power, 8MB/16MB/128MB Flash (M1w module add wifi chip esp8285 on it) into Square Inch Module. All usable IO breaks out as 1.27mm(50mil) pins, and pin's voltage is selectable from 3.3V and 1.8V.

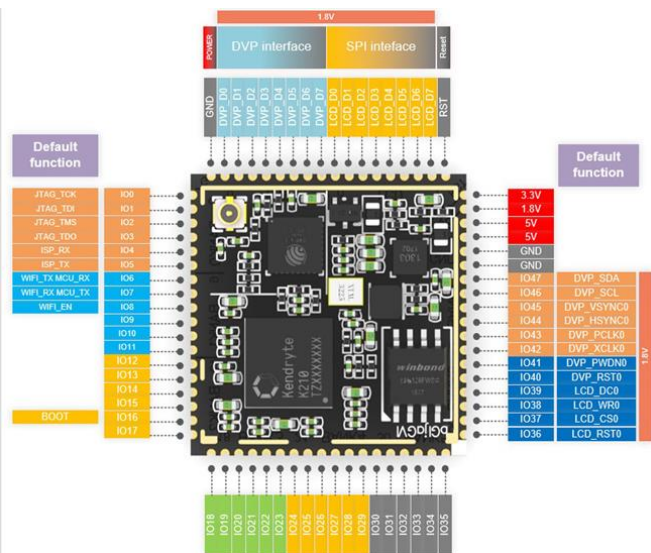
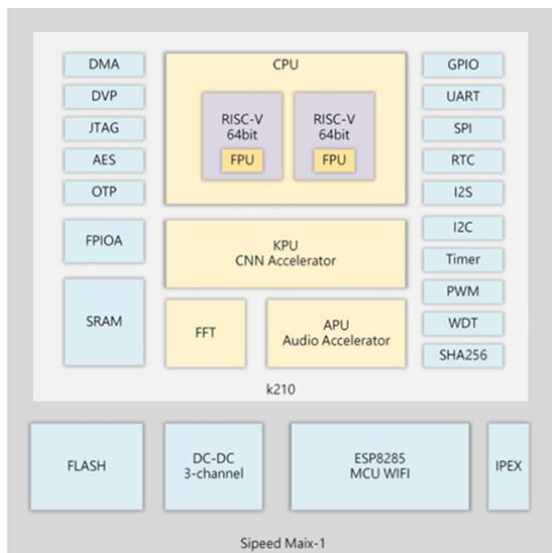

MAix's SoftWare

MAIX support original standalone SDK, FreeRTOS SDK base on C/C++.

And we port micropython on it: <http://en.maixpy.sipeed.com/>. It support FPIOA, GPIO, TIMER, PWM, Flash, OV2640, LCD, etc. And it have zmodem, vi, SPIFFS on it, you can edit python directly or sz/rz file to board. We are glad to see you contribute for it:

<https://github.com/sipeed/MaixPy> //Maixpy project

https://github.com/sipeed/MaixPy_Doc_Us_En_Backup //Maixpy wiki project

MAix's Deep learning

MAIX support fixed-point model that the mainstream training framework trains, according to specific restriction rules, and have model compiler to compile models to its own model format.

It support tiny-yolo, mobilenet-v1, and, TensorFlow Lite! Many TensorFlow Lite model can be compiled and run on MAIX! And We will soon release model shop, you can trade your model on it.

Technical details

Dimensions	60mm x43mm x5mm
Weight	G.W 30g
Battery	Exclude

Part List

M1w (w means wifi) dock(mic and pa on board)	1
2.4 inch LCD	1
OV2640 Camera	1
Antenna	1
Type-C to USB Convert	1