

# 4AV SERIES

006000  
Issue 1

## Solid State Vane Switches

### DESCRIPTION

The 4AV Series vane-operated, integral magnet, position solid state switches are operated by passing a ferrous vane through the air gap between the Hall-effect sensor and the magnet, shunting the magnetic flux away from the sensor.

This product may be used as a limit switch by operating with a single large vane, as a tachometer sensor by using a toothed wheel, or as a synchronizing element by using a cam or a sector.

### POTENTIAL APPLICATIONS

#### INDUSTRIAL

- Motors and drives
- Test and measurement

#### AEROSPACE

- Plane windscreen wipers
- Door position

#### MEDICAL

- Motion detection in motorized equipment

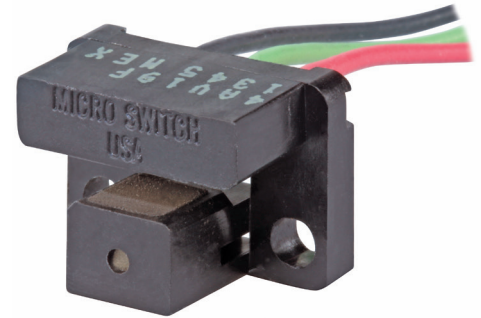

### FEATURES

- Magnet and sensor are incorporated in the same rugged package
- Operated by a low cost, easy to fabricate, ferrous vane interrupter
- -40°C to 125°C temperature range
- Current sinking output
- Closely controlled differential to predict pulse width
- 4.5 Vdc to 26 Vdc power supply
- Leadwire termination: 24 AWG with crosslink polyethylene insulation of 0.060 max OD
- Sealed construction is unaffected by dust or dirt
- 0 kHz to 100 kHz operating speed means no minimum speed of operation
- ON and OFF times are adjustable by vane dimensioning
- Precision mechanical operating characteristics

### PORTFOLIO



The 4AV Series is a part of the Value Added Packaged Sensors portfolio, which also includes the SR16 and SR17 vane switches. To view the entire product portfolio, [click here](#).

**Honeywell**

## 4AV SERIES SOLID STATE VANE SWITCHES

**TABLE 1. ABSOLUTE MAXIMUM RATINGS<sup>1,2</sup>**

Characteristic	Parameter
Supply voltage ( $V_{\text{supply}}$ )	$\pm 30$ Vdc
Voltage applied to output	-0.5 Vdc to +30 Vdc
Output current	$\pm 50$ mA
Temperature	-40°C to 150°C [-40°F to 302°F]
Transient supply current	$\pm 0.5$ A at 15 $\mu$ s max.
Transient output current	$\pm 0.5$ A at 15 $\mu$ s max.

<sup>1</sup> Absolute maximum ratings are the extreme limits the device will withstand without damage. However, the electrical and mechanical characteristics are not guaranteed above the recommended operating conditions nor will the device necessarily function. Ratings are to be considered individually, not combined.

<sup>2</sup> The output current maximum is the total of the output sinking currents.

**TABLE 2. ELECTRICAL SPECIFICATIONS**

Characteristic	Symbol	Operating Condition
Supply voltage	$V_{\text{CC}}$	4.5 Vdc to 26.5 Vdc
Supply current ON	$I_{\text{CC}}$	5 mA to 18.5 mA
Output voltage ON	$V_{\text{sat}}$	0 Vdc to 0.4 Vdc (sinking 20 mA) 0 Vdc to 0.5 Vdc (sinking 40 mA)
Output current OFF	$I_{\text{leak}}$	0 $\mu$ A to 10 $\mu$ A pulled up to 24 Vdc max.
Output switching rise time	$t_r$	0 $\mu$ s to 1.5 $\mu$ s ( $V_{\text{CC}} = 12$ V, $R_{\text{load}} = 1$ kOhm, $C_{\text{load}} = 20$ pF at 25°C max.)
Output switching fall time	$t_f$	0 $\mu$ s to 1.0 $\mu$ s ( $V_{\text{CC}} = 12$ V, $R_{\text{load}} = 1$ kOhm, $C_{\text{load}} = 20$ pF at 25°C max.)
Reverse supply voltage current	$I_{\text{CCR}}$	-2.5 mA to 0 mA (-30 $V_{\text{supply}}$ , 0 V output applied)

<sup>1</sup> Electrical characteristics are specified over the voltage and temperature range using an actuator 0.040 in thick with a 0.400 in tooth and window passing through the center of the air gap.

<sup>2</sup> Switch is OFF (release condition) when the vane actuator tooth is in the air gap.

**TABLE 3. MECHANICAL SPECIFICATIONS<sup>1,2</sup>**

Supply Voltage (VDC)	Operating Temperature (°C)	Left		Right		Differential: Left Operate to Right Release, Right Operate to Left Release (in)
		Operate (in)	Release (in)	Operate (in)	Release (in)	
4.5 to 24.0 <sup>3</sup>	25	$\pm 0.006$	$\pm 0.006$	$\pm 0.006$	$\pm 0.006$	$\pm 0.010$
12.0	25	0.213 $\pm$ 0.025	0.237 $\pm$ 0.025	0.337 $\pm$ 0.025	0.313 $\pm$ 0.025	0.01 $\pm$ 0.01
4.5 to 24.0 <sup>3</sup>	-40 to 85	$\pm 0.024$	$\pm 0.018$	$\pm 0.024$	$\pm 0.018$	-
4.5 to 24.0 <sup>3</sup>	-40 to 125	$\pm 0.040$	$\pm 0.030$	$\pm 0.040$	$\pm 0.030$	$\pm 0.070$

<sup>1</sup> Electrical characteristics are specified over the voltage and temperature range using an actuator 0.040 in thick with a 0.400 in tooth and window passing through the center of the air gap.

<sup>2</sup> Switch is OFF (release condition) when the vane actuator tooth is in the air gap.

<sup>3</sup> Maximum change in vane travel mechanical characteristics switching point referencing 25°C and a 12 Vdc initial condition.

# 4AV SERIES SOLID STATE VANE SWITCHES

**TABLE 4. TRANSIENT CHARACTERISTICS (REFERENCE ISO 7636-1 AT 25°C)**

Characteristic	PULSE	DURATION	VOLTAGE
Inductive load opening	1	<0.2 ms	-110 V
Inductive load opening	1	<2 ms	-100 V
Series current interrupt	2	<200 ms	+150 V
Load dump	5	<400 ms	+120 V
Field decay	36	<100 ns	+200 V
Negative transient	39	<100 ns	-200 V
RF1	1 MHz through 1000 MHz		>40 V/M

**TABLE 5. ORDER GUIDE**

Catalog Listing	Description
4AV18F	4AV19F solid state vane switch, 18.15 in wire leads
4AV19F	4AV19F solid state vane switch, 22 in wire leads

**FIGURE 1. BLOCK DIAGRAM SHOWING SINKING OUTPUT**

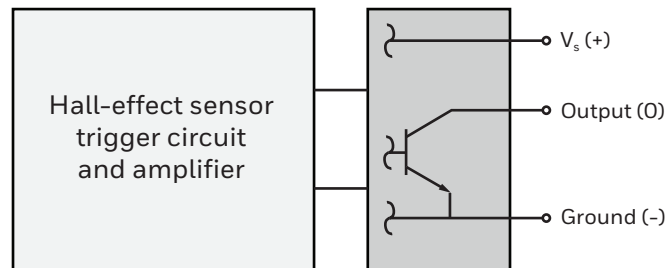

# 4AV SERIES SOLID STATE VANE SWITCHES

FIGURE 2. MOUNTING DIMENSIONS (FOR REFERENCE ONLY (IN))

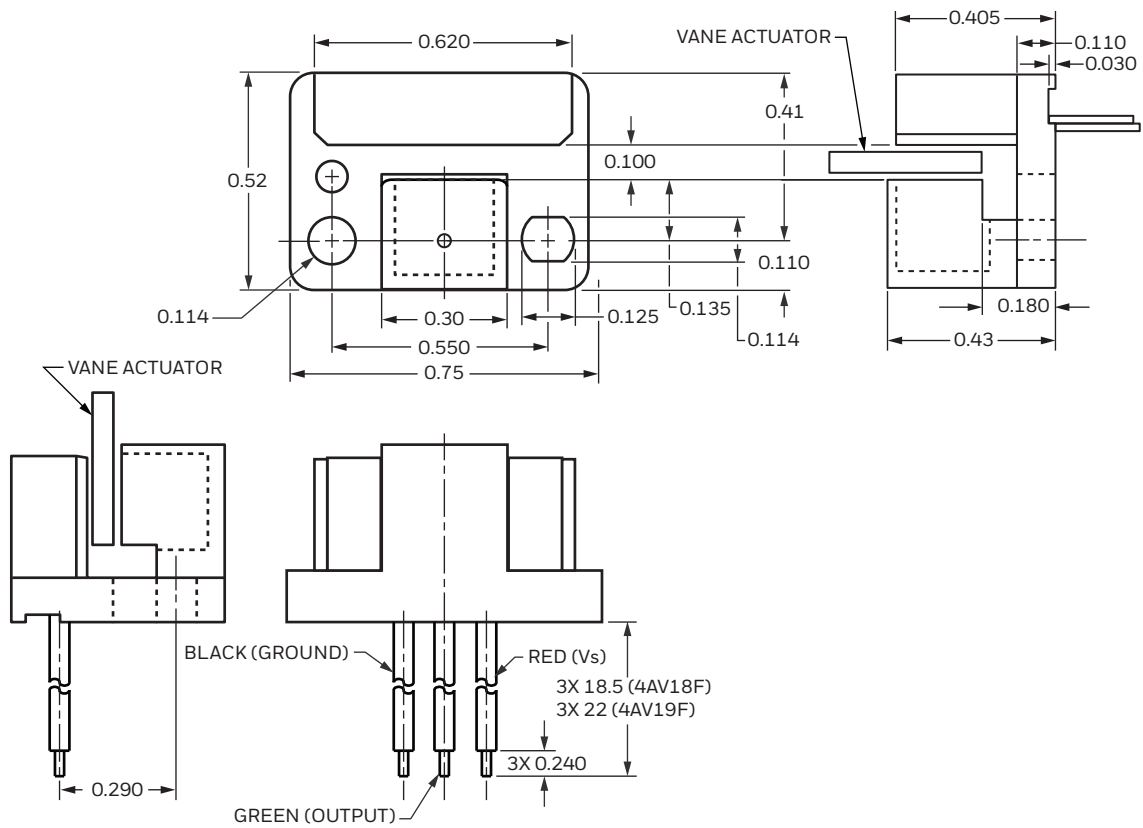

FIGURE 3. VANE DIMENSIONS (FOR REFERENCE ONLY (IN))

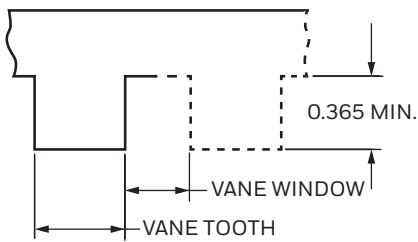

TABLE 6. VANE ACTUATOR DIMENSIONS

Actuator Thickness (in)	Minimum Window (in)	Minimum Tooth (in)
0.040	0.400	0.400
0.062	0.400	0.250

# 4AV SERIES SOLID STATE VANE SWITCHES

**TABLE 7. VANE OPERATION**

Output	Vane Position
<p>No vane in the air gap. The output is conducting (sinking is low, sourcing is high).</p>	
<p>Vane moves from left to right. When the vane leading edge reaches <b>B</b>, the output stops conducting (sinking goes high, sourcing goes low).</p>	
<p>After the vane leading edge reaches <b>B</b>, if the vane moves on through the air gap, and when its trailing edge reaches <b>D</b>, the output will be conducting.</p>	

# 4AV SERIES SOLID STATE VANE SWITCHES

**TABLE 7. VANE OPERATION (CONTINUED)**

Output	Vane Position
<p>After the vane leading edge reaches <b>B</b>, if the direction of vane travel reverses, and when the new vane leading edge reaches <b>A</b>, the output is conducting.</p>	
<p>Vane moves from right to left. When the vane leading edge reaches <b>C</b>, the output is non-conducting</p>	
<p>Vane moves from right to left. When the vane trailing edge reaches <b>A</b>, the output is conducting.</p>	

## WARRANTY/REMEDY

Honeywell warrants goods of its manufacture as being free of defective materials and faulty workmanship during the applicable warranty period. Honeywell's standard product warranty applies unless agreed to otherwise by Honeywell in writing; please refer to your order acknowledgment or consult your local sales office for specific warranty details. If warranted goods are returned to Honeywell during the period of coverage, Honeywell will repair or replace, at its option, without charge those items that Honeywell, in its sole discretion, finds defective.

**The foregoing is buyer's sole remedy and is in lieu of all other warranties, expressed or implied, including those of merchantability and fitness for a particular purpose. In no event shall Honeywell be liable for consequential, special, or indirect damages.**

While Honeywell may provide application assistance personally, through our literature and the Honeywell web site, it is buyer's sole responsibility to determine the suitability of the product in the application.

Specifications may change without notice. The information we supply is believed to be accurate and reliable as of this writing. However, Honeywell assumes no responsibility for its use.

## FOR MORE INFORMATION

Honeywell Advanced Sensing Technologies services its customers through a worldwide network of sales offices and distributors. For application assistance, current specifications, pricing or the nearest Authorized Distributor, visit [our website](#) or call:

USA/Canada	+1 302 613 4491
Latin America	+1 305 805 8188
Europe	+44 1344 238258
Japan	+81 (0) 3-6730-7152
Singapore	+65 6355 2828
Greater China	+86 4006396841

## Honeywell Advanced Sensing Technologies

830 East Arapaho Road  
Richardson, TX 75081  
[sps.honeywell.com/ast](https://sps.honeywell.com/ast)

006000-1-EN | 1 | 06/22  
© 2022 Honeywell International Inc. All rights reserved.

## WARNING PERSONAL INJURY

DO NOT USE these products as safety or emergency stop devices or in any other application where failure of the product could result in personal injury.

**Failure to comply with these instructions could result in death or serious injury.**

## WARNING MISUSE OF DOCUMENTATION

- The information presented in this datasheet is for reference only. Do not use this document as a product installation guide.
- Complete installation, operation, and maintenance information is provided in the instructions supplied with each product.

**Failure to comply with these instructions could result in death or serious injury.**

# Honeywell