

SPS SERIES

000674
Issue 7

SMART Position Sensors

DESCRIPTION

The SMART Position Sensor is one of the most durable, adaptable, and lightweight linear position sensors available in the industry, enabling highly accurate motion control and improving operation efficiency and safety. Its simple, non-contact design eliminates mechanical failure mechanisms, reducing wear and tear, improving reliability and durability, and minimizing downtime.

The SMART Position Sensor is a non-contacting sensing solution for absolute position sensing with enhanced accuracy. It senses the position of a magnet relative to the sensor in one of three available sensing ranges:

- 0 mm to 35 mm [0 in to 1.38 in]
- 0 mm to 75 mm [0 in to 2.95 in]
- 0 mm to 225 mm [0 in to 8.86 in]

These sensors use a patented combination of an ASIC (Application-Specific Integrated Circuit) and an array of MR (magneto-resistive) sensors to accurately and reliably determine the position of a magnet attached to a moving object so that the object's position can be determined or controlled.

The MR array measures the output of the MR sensors mounted along the magnet's direction of travel. The output and the MR sensor sequence determine the nearest pair of MR sensors to the center of the magnet location. The output of these two MR sensors is then used to determine the position of the magnet between them.

The SMART Position Sensor is available in both analog output (35 mm, 75 mm and 225 mm configurations) and digital output (225 mm configuration only) for use in control systems requiring an RS232-type interface with a 57.6 kbits/s baud rate.

FEATURES

- **Reliable:** Non-contact design reduces wear and tear, improving reliability and durability, and minimizing downtime
- **Installation** takes four simple steps (1: position sensor; 2: drill holes; 3: mount sensor; 4: locate magnet actuator/ make electrical connection)
- **Rugged:** As there are no moving parts within the sensor, Honeywell utilizes unique packaging materials that make the sensor more resistant to vibration, shock, and extreme temperatures
- **Air gap** of up to 8,5 ±1,0 mm [0.334 ±0.039 in] between sensor and magnet expands application opportunities; variety of output options (analog standard and other RS232-type baud rates) are available, expanding application opportunities
- **Accurate:** 35 mm configuration accurately measures values down to 0,04 mm [0.0016 in], 75 mm configuration accurately measures values down to 0,05 mm [0.002 in], while 225 mm configuration accurately measures value down to 0,14 mm [0.0055 in] (analog) and 0,0035 mm [0.000137 in] (digital)
- **Adaptable:** Electronics on board allow for flexible packaging and component compatibility with existing systems
- **More than 50% lighter** in weight than LVDT (Linear Variable Differential Transformer) technology
- **Easy-to-configure** sensor array fits virtually any linear movement path
- **Self-diagnostics** feature can reduce equipment downtime by providing predictive maintenance input
- **IP67 and IP69K** sealing allows use in many harsh applications
- **Qualified** for automotive grade EMI/ EMC specification provides protection against environmental frequencies (35 mm configuration only)
- **RoHS-compliant** materials meet Directive 2002/95/EC



POTENTIAL APPLICATIONS

(May not apply to all configurations.)

- **Industrial:** Valve position, Material handling, plastic molding, cutting and slitting, wafer handling, CNC machines
- **Transportation:** Engine transmissions, passenger bus level position, truck-mounted crane outrigger position, heavy equipment attachment identification, hydraulic cylinders, marine motors
- **Aerospace:** Aircraft actuators



PORTFOLIO





In addition to the SPS Series Linear configurations, other configurations include the Arc and Rotary.

Honeywell

SMART POSITION SENSORS

SPS SERIES

TABLE 1. SPECIFICATIONS

CHARACTERISTIC	COMPONENT	PARAMETER			
		35 mm	75 mm	225 mm	
		SPS-L035-LATS (analog) 	SPS-L075-HALS (analog) 	SPS-L225-HALS (analog) 	SPS-L225-HDLS ² (digital) 
Sensing range	sensor only	0 mm to 35 mm [0 in to 1.38 in]	0 mm to 75 mm [0 in to 2.95 in]	0 mm to 225 mm [0 in to 8.86 in]	
Resolution		0,04 mm [0.0016 in]	0,05 mm [0.002 in]	0,14 mm [0.0055 in]	0,0035 mm [0.000137 in]
Supply voltage		4.75 Vdc to 5.25 Vdc	6 Vdc to 24 Vdc		
Output		0.55 Vdc to 4.15 Vdc	0 Vdc to 5 Vdc		RS 232-type digital
Supply current		20 mA max.	32 mA max.	34 mA max.	88 mA max.
Linearity ¹		±1.0% full scale output	±0.4% full scale output		
Reverse polarity		-5 V	26.4 V at 125°C [257°F]		
Sensitivity		103 mV/mm typ.	50 mV/mm typ.	17.78 mV/mm typ.	282.16 counts/mm typ.
Update rate		476 µs	400 µs		3200 µs
Baud rate			-		57.6 kbits/s
Initial startup time		5 ms	30 ms		
Termination		TYCO Super Seal 282087-1 integral connector	flying leads		
Cable bend radius		-	40 mm [1.6 in] min.		
Operating temperature			-40°C to 125°C [-40°F to 257°F]		
Storage temperature		-40°C to 150°C [-40°F to 302°F]			
Air gap		8,5 ±1,0 mm [0.334 ±0.039 in]	3,0 ±2,5 mm [0.118 ±0.098 in]		
Sealing		IP67, IP69K			
Radiated immunity	sensor and magnet actuator	100 V/m per ISO 11452-2	-		
Conducted immunity		100 mA BCI per ISO 11452-4	-		
Shock		50 G half sine wave with 11 ms duration			
Vibration		20 G from 10 Hz to 2000 Hz	10 G from 10 Hz to 2000 Hz		
Housing material		thermoplastic			
Approvals		CE, UKCA			
Mounting: screws recommended torque		¼-20 or M6 6 N m to 10 N m [53.1 in-lb to 88.5 in-lb]			
Material	magnet	neodymium iron boron			
Strength	actuator only	13,500 Gauss	10,000 Gauss		

¹ Percent linearity is the quotient of the measured output deviation from the best fit line at the measured temperature to the full scale output span.

² The RS232 digital output is encoded at 0 V to 5 V signal levels. A TTL to RS232 level shifter is required for directly compatible RS232 signals. The digital position output is in two, 8-bit bytes with the high-order byte being first. Each byte is constructed as follows: one start bit, eight data bits, one even parity bit, and one stop bit.

NOTICE

- Ferrous metal within a 100 mm [3.9 in] radius of the magnet actuator may affect sensor performance.
- Always use fresh, non-magnetic stainless steel washers when mounting the sensor.

SMART POSITION SENSORS SPS SERIES

**FIGURE 1. SPS-L035-LATS MOUNTING DIMENSIONS (FOR REFERENCE ONLY: MM)
AND SENSOR OUTPUT PERFORMANCE GRAPH**

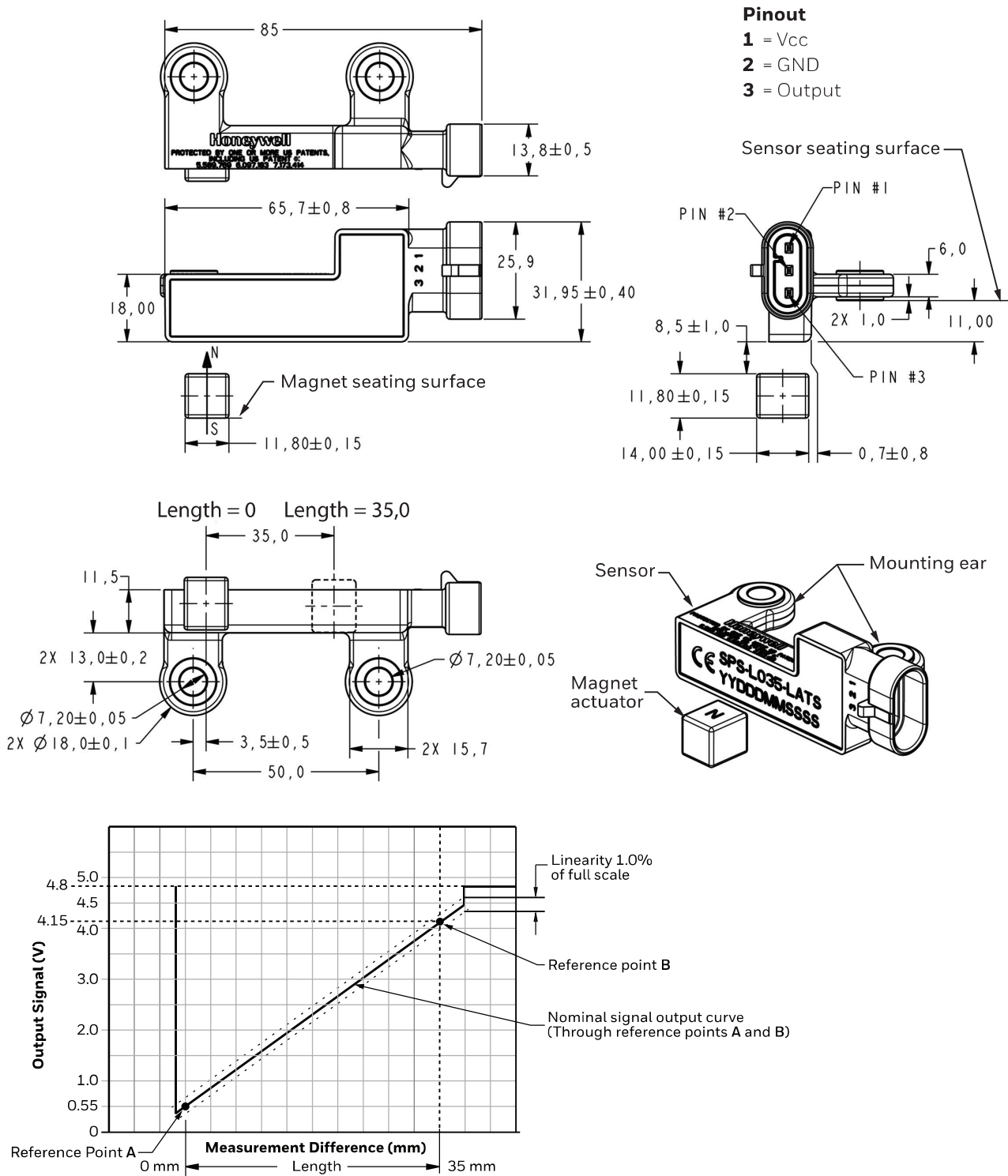

SMART POSITION SENSORS SPS SERIES

FIGURE 2. SPS-L075-HALS MOUNTING DIMENSIONS (FOR REFERENCE ONLY: MM)
AND SENSOR OUTPUT PERFORMANCE GRAPH

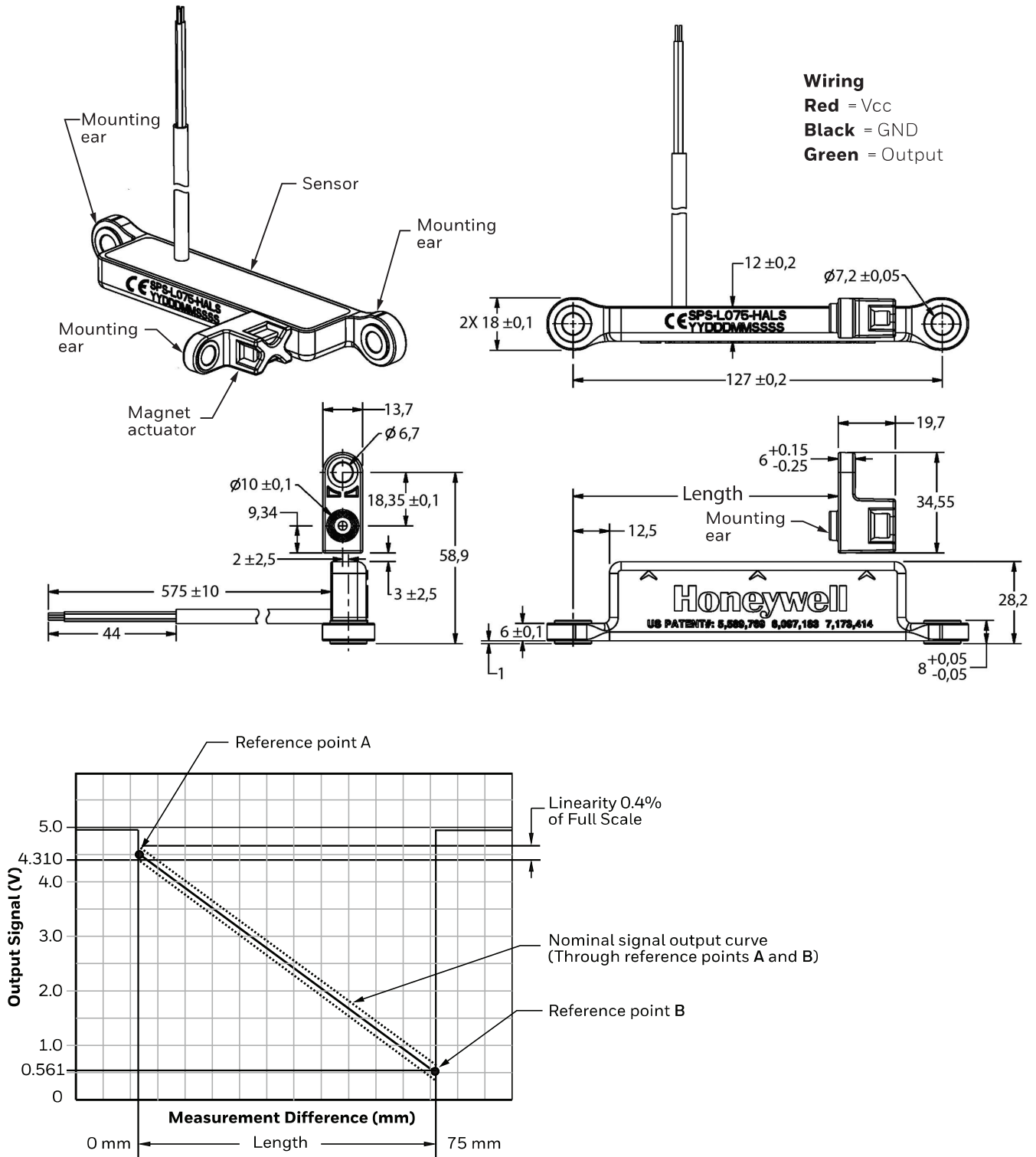

SMART POSITION SENSORS SPS SERIES

FIGURE 3. SPS-L225-HALS MOUNTING DIMENSIONS (FOR REFERENCE ONLY: MM)
AND SENSOR OUTPUT PERFORMANCE GRAPH

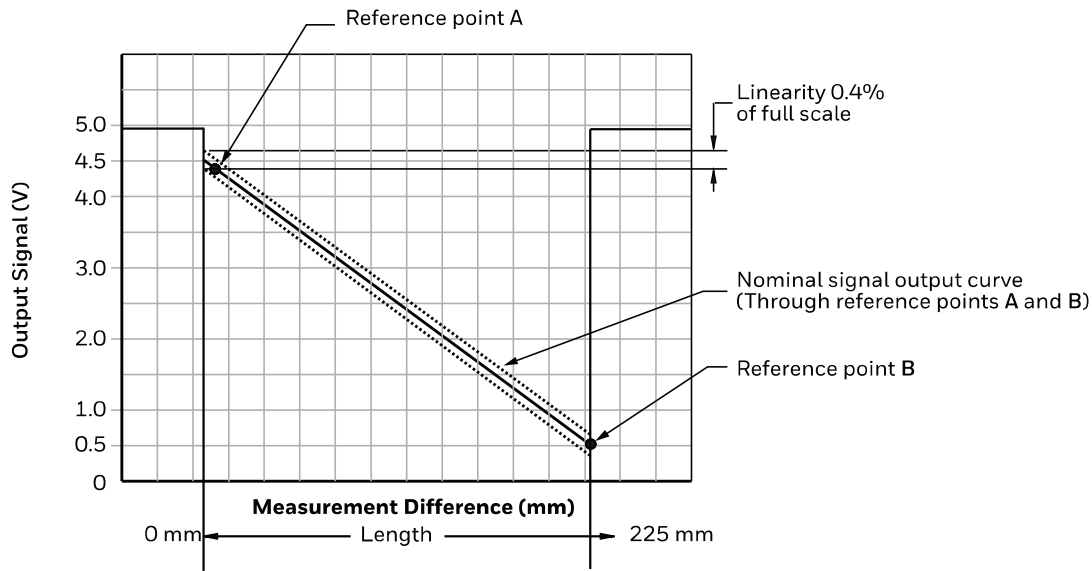
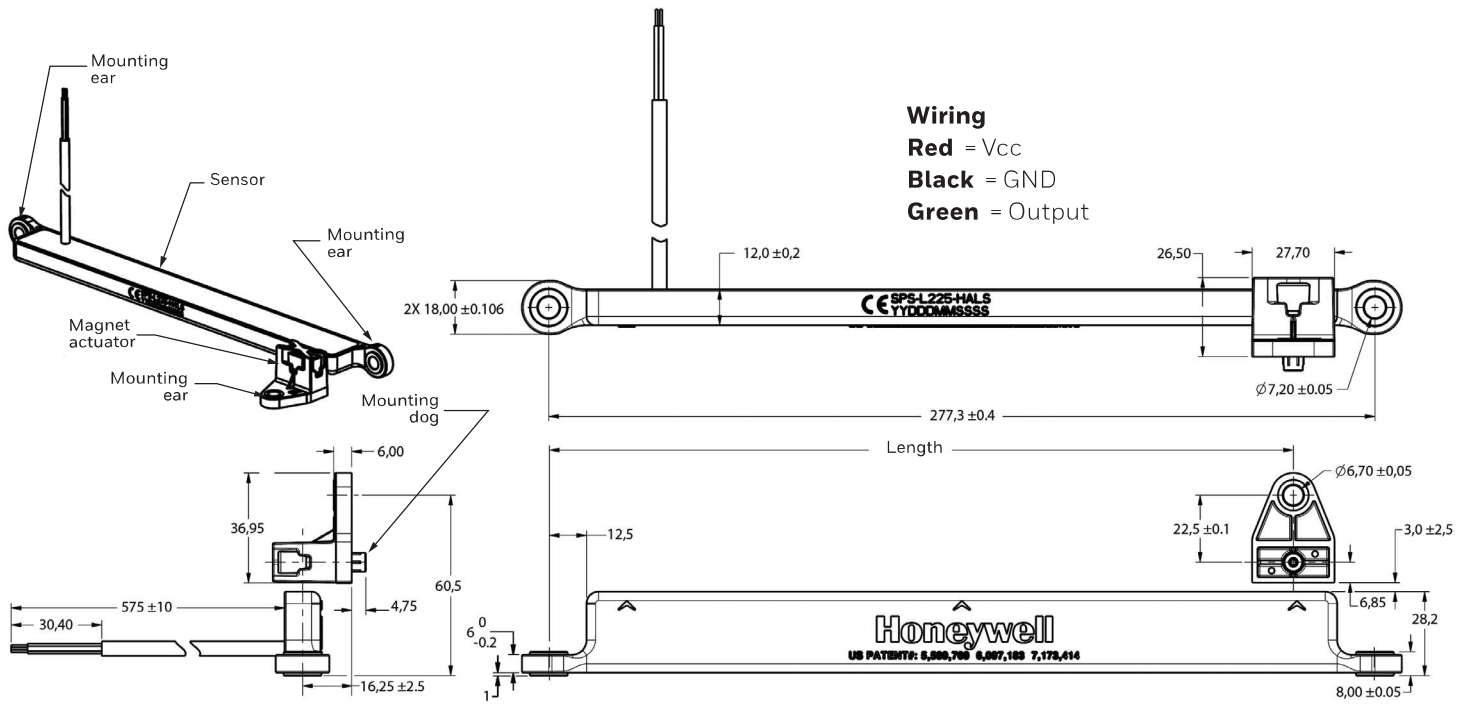

SMART POSITION SENSORS SPS SERIES

**FIGURE 4. SPS-L225-HDLS MOUNTING DIMENSIONS (FOR REFERENCE ONLY: MM)
AND SENSOR OUTPUT PERFORMANCE GRAPH**

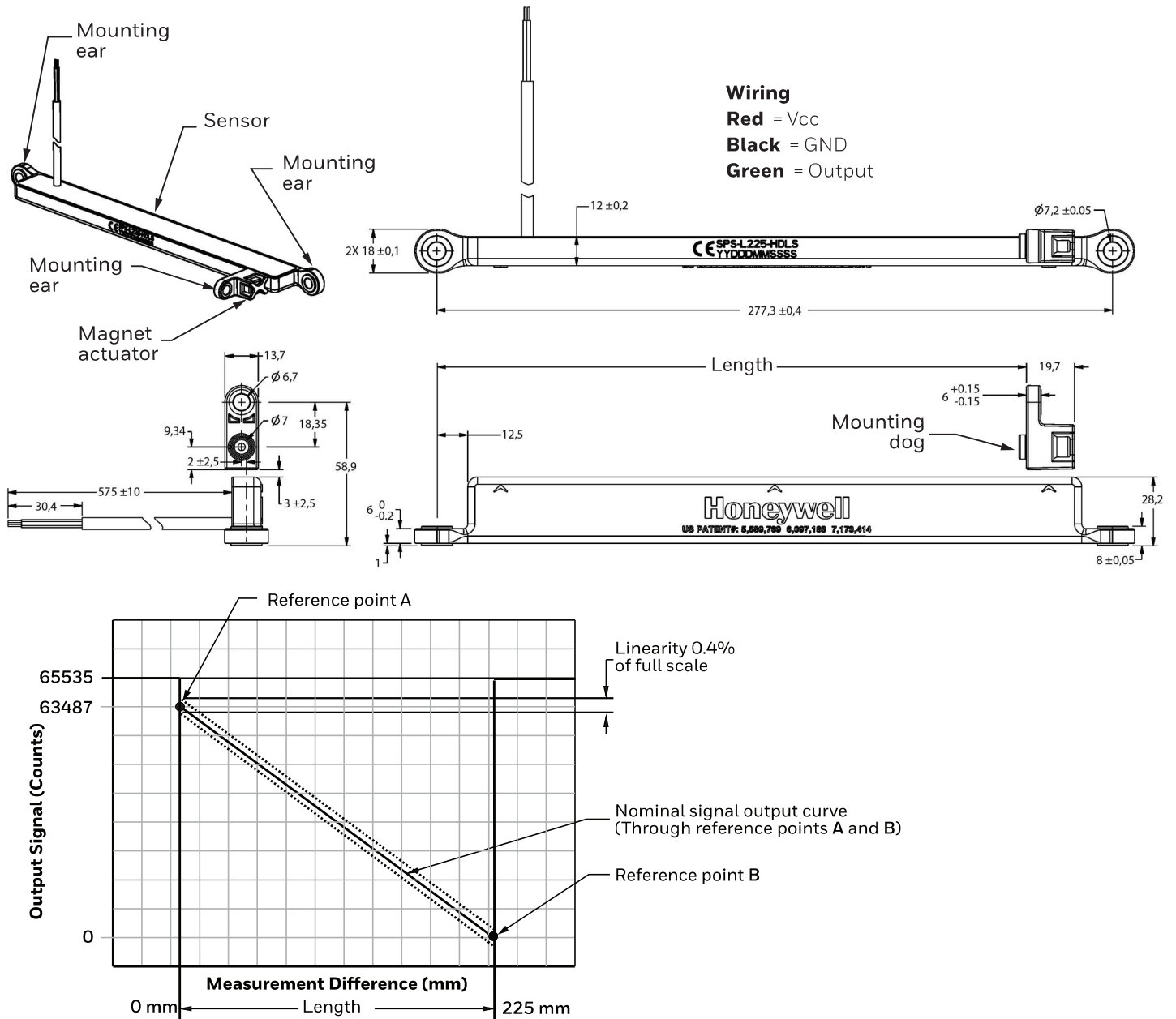

TABLE 2. ORDER GUIDE

CATALOG LISTING	DESCRIPTION
SPS-L035-LATS	SPS Series SMART Position Sensor, 35 mm linear configuration, 0 mm to 35 mm [0 in to 1.38 in] sensing range, 0.5 Vdc to 4.5 Vdc analog output, magnet actuator included (sensor also available separately)
SPS-L075-HALS	SPS Series SMART Position Sensor, 75 mm linear configuration, 0 mm to 75 mm [0 in to 2.95 in] sensing range, 0 Vdc to 5 Vdc analog output, magnet actuator included
SPS-L225-HALS	SPS Series SMART Position Sensor, 225 mm linear configuration, 0 mm to 225 mm [0 in to 8.86 in] sensing range, 0 Vdc to 5 Vdc analog output, magnet actuator included
SPS-L225-HDLS	SPS Series SMART Position Sensor, 225 mm linear configuration, 0 mm to 225 mm [0 in to 8.86 in] sensing range, RS232-type digital output with 57.6 kbits/s baud rate, magnet actuator included

ADDITIONAL MATERIALS

The following associated literature is available at sensing.honeywell.com:

- Product line guide
- Product range guide
- Product installation instructions
- Product CAD models

WARRANTY/REMEDY

Honeywell warrants goods of its manufacture as being free of defective materials and faulty workmanship during the applicable warranty period. Honeywell's standard product warranty applies unless agreed to otherwise by Honeywell in writing; please refer to your order acknowledgment or consult your local sales office for specific warranty details. If warranted goods are returned to Honeywell during the period of coverage, Honeywell will repair or replace, at its option, without charge those items that Honeywell, in its sole discretion, finds defective. **The foregoing is buyer's sole remedy and is in lieu of all other warranties, expressed or implied, including those of merchantability and fitness for a particular purpose. In no event shall Honeywell be liable for consequential, special, or indirect damages.**

While Honeywell may provide application assistance personally, through our literature and the Honeywell web site, it is buyer's sole responsibility to determine the suitability of the product in the application.

Specifications may change without notice. The information we supply is believed to be accurate and reliable as of this writing. However, Honeywell assumes no responsibility for its use.

FOR MORE INFORMATION

Honeywell Advanced Sensing Technologies services its customers through a worldwide network of sales offices and distributors. For application assistance, current specifications, pricing or the nearest Authorized Distributor, visit sps.honeywell.com/ast or call:

USA/Canada	+1 302 613 4491
Latin America	+1 305 805 8188
Europe	+44 1344 238258
Japan	+81 (0) 3-6730-7152
Singapore	+65 6355 2828
Greater China	+86 4006396841

Honeywell

Advanced Sensing Technologies

830 East Arapaho Road
Richardson, TX 75081
sps.honeywell.com/ast

WARNING PERSONAL INJURY

DO NOT USE these products as safety or emergency stop devices or in any other application where failure of the product could result in personal injury.

Failure to comply with these instructions could result in death or serious injury.

WARNING MISUSE OF DOCUMENTATION

- The information presented in this product sheet is for reference only. Do not use this document as a product installation guide.
- Complete installation, operation, and maintenance information is provided in the instructions supplied with each product.

Failure to comply with these instructions could result in death or serious injury.