

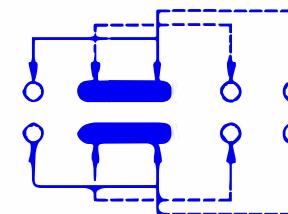

CAD FILE:

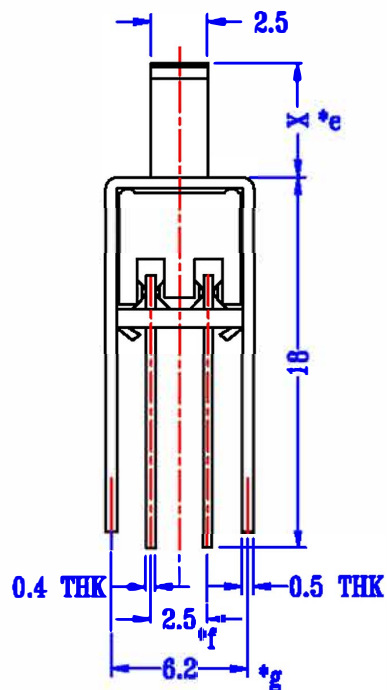

SCHMATIC (SHORTING)

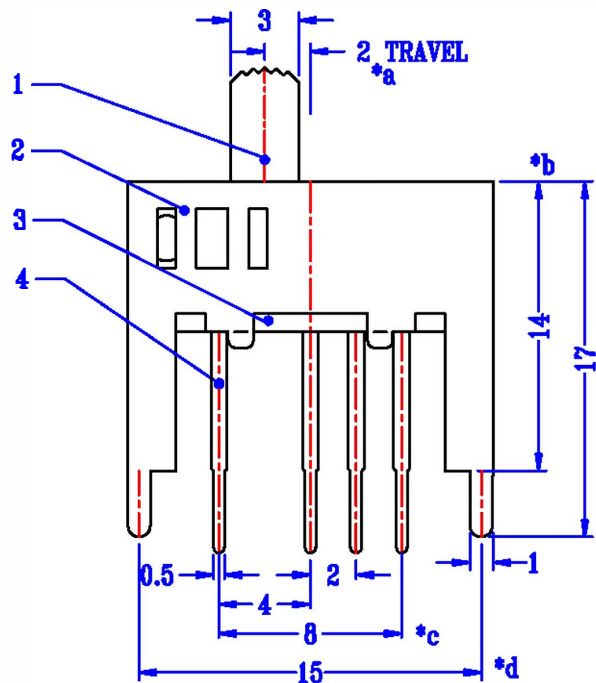
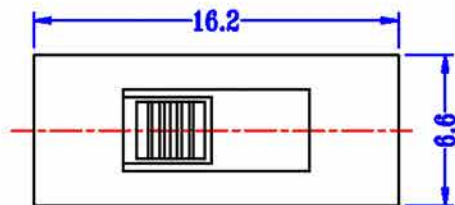
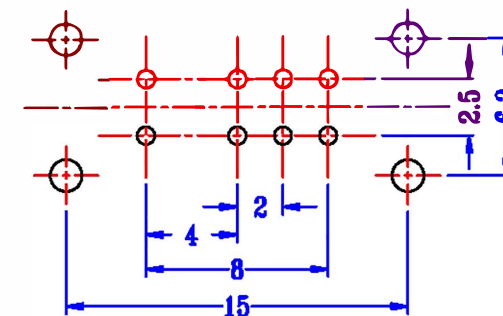

**P.C.B LAYOUT
BOTTOM VIEW**

8					TOLERANCE UNLESS SPECIFIED					
7	STEEL BALL	STEEL	1	NATURAL	WITHIN 1.5mm : ±0.1mm					
6	SPRING	STEEL WIRE	1	TEMPER	OVER 1.5mm : ±0.2mm					
5	CONTACT CLIP	PBS STRIP	2	Ag PLATED	ISSUE	DATE	DESCRIPTIONS OF REVISION		APPD.	
4	TERMINAL	BRASS STRIP	8	Ag PLATED	TITLE : VERTICAL SLIDE SWITCH		UNIT : mm			
3	BASE	PHENOLIC RESIN	1	NATURAL	MODEL: L-KLS7-SS-23D29-G5		SCALE: 3:1	DWN.		
2	FRAME	STEEL STRIP	1	Ni PLATED	NINGBO KLS ELECTRONIC CO.,LTD			CHK'D		
1	KNOB	POM	1	BLACK				APPD.		
NO.	PARTS	MATERIALS	Q'TY	FINISH						