

产品说明 Product Description:

1.表面处理 Surface treatment:

电镀Sn(雾锡) Matte tin plating

2.外观 Appearance:

>30CM距离, <5S目视, 无腐蚀、刮伤、氧化

No corrosion, scratches, oxidation on surface

Inspection condition:

Inspect from >30cm away and for <5 seconds

3.盐雾测试 Salt spray test:

24h, 等级7级(GB)

24 hours, grade 7 (GB)

4.环保: 符合ROHS&REACH

RoHS&REACH compliance: Yes

REV. (版本)	DESCRIPTION (修改内容)	DATE. (日期)
A	初始版本 Initial release	2005.03.16
B	增加规范	2007.07.31
C	变更适柳电线	2009.06.05

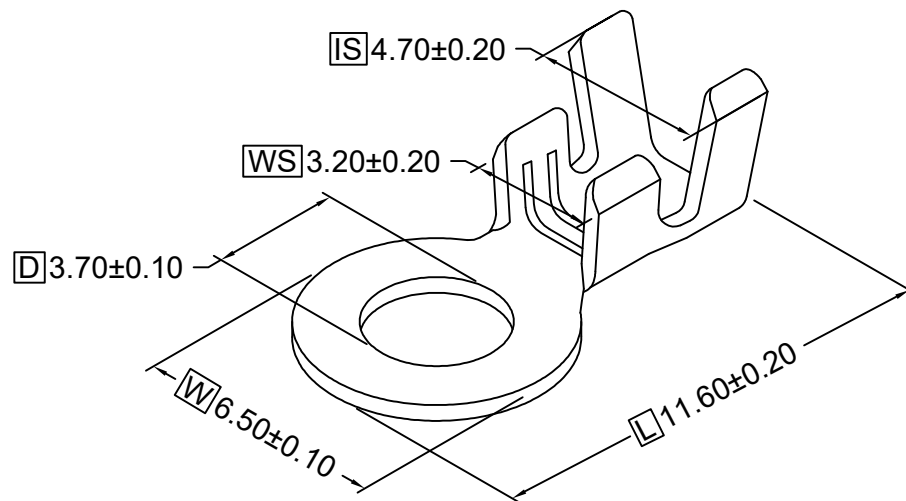
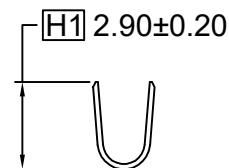
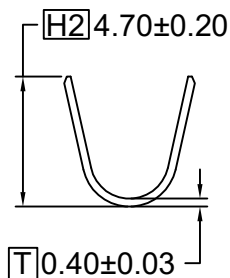

核准 APPROVED		审核 CHECKED		制图 DRAWING		尺寸单位 Units		mm	
		周顺龙		郭士宾		日期 DATE		版本 REV.	
						2020.09.08		C	

产品料号 Part NO.	R370992BS2	文件名称 File Name	规格图 Product Specification
产品规格 Note	-	文件编号 File NO.	-
客户料号 Customer's Part NO.	-	单重 Single Weight	-
材质 Material	黄铜Brass(C2680)	包装数量 Packing Q' TY	15000Pcs/Reel
适配端子 Mating Part/ Spec.	-	认证编号 Certification NO.	-

