

Dept	
Qty	
DC	1
ED	1
IE	1
ISO	1
PD	1
R&D	1
SD	1
QA	1
QC	1
QE	1

The information provided herein is from CONNPLY Electronic Co., Ltd. and is confidential. Any disclosure to a party other than the recipient is prohibited. The intellectual properties and its rights contained herein, including but not limited to, trademarks, patents, copyrights, trade secrets, and technical know-how, are owned exclusively by CONNPLY or its affiliates. Unauthorized use of this information in any format or manner, CONNPLY may enforce its intellectual property rights at its own discretion; failures or delays to exercise such rights does not constitute a waiver of such rights.

REV.	DESCRIPTION	DRAWN	CHECKED	APPROVED
A	NEW RELEASE	JLZ 01/18/21'		

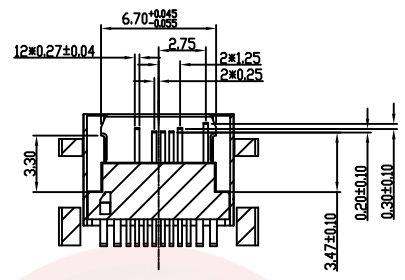
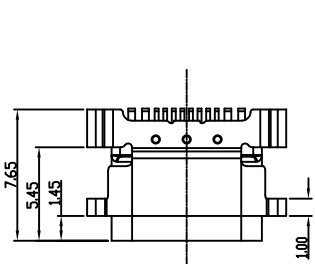

SECTION B-B
SCALE: 1:1

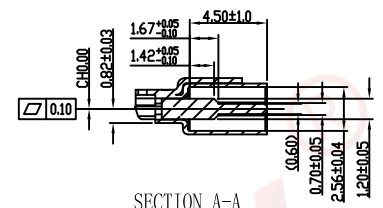
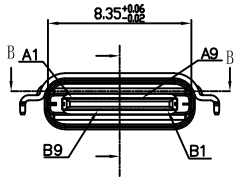

SECTION A-A
SCALE: 1:1

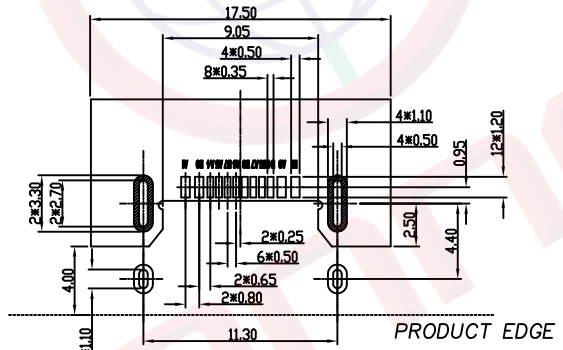
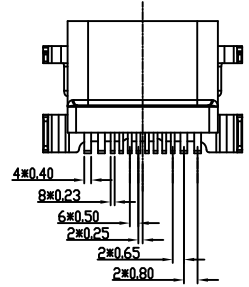

RECOMMENDED PCB LAYOUT(TOP VIEW)
THICKNESS 0.8±0.10MM; DEFAULT TOLERANCE: ±0.05



- NOTES:
- MATERIAL:
 - HOUSING:SEE TABLE ORDERING INFORMATION
 - CONTACTS:Copper Alloy(C7025)
 - SHELL:Stainless steel
 - ELECTRICAL CHARACTERISTICS:
 - CONTACT RESISTANCE:40mΩ Max FOR INTIAL, 10mΩ CHANGE AFTER TEST. MEASURE at 20mv, 100mA.
 - CONTACT CURRENT RATING:3A FOR VBUS PIN;1.25A FOR VCONN and GND PIN;0.25A FOR all THE OTHER PIN.
 - VOLTAGE RATING:30V
 - DIELECTRIC WITHSTANDING VOLTAGE:100 V R. M. S.
 - INSULATION RESISTANCE 100 MEGOHMS MIN
 - MECHANICAL PERFORMANCE:
 - INSERT FORCE:0.51-2.04Kg
 - EXTRACT FORCE:0.82-2.04Kg
 - AFTER DURABILITY:0.61-2.04Kg
 - DURABILITY:10000 CYCLES
 - ENVIRONMENTAL:
 - OPERATION TEMPERATURE : -20°C to +85°C

5.Product number code:
DS1144- 49- X X X X X X X X

No. of contacts	12: 12pin	Packing Type	R: Tape On Reel
Connector type	F: Female	Shell Plating	N: Full Nickel
Mounting type	S: SMT type	Housing color	B: Black
		Contact Plating	4:Selective 3u" gold
			0:Selective gold flash

A12	A11	A10	A9	A8	A7	A6	A5	A4	A3	A2	A1
			VBUS		D-	D+	Vconn	VBUS			GND
GND			VBUS	Vconn	D+	D-		VBUS			
B1	B2	B3	B4	B5	B6	B7	B8	B9	B10	B11	B12

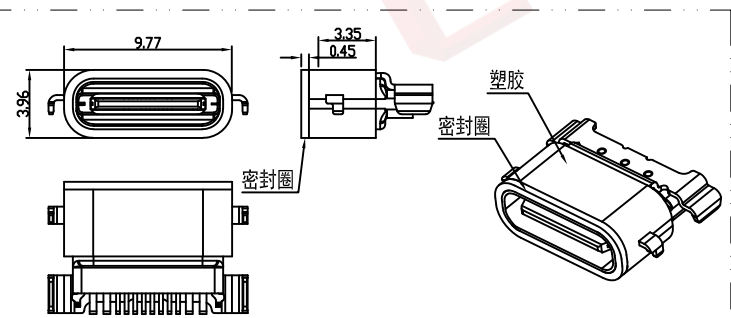

Schematic diagram with waterproof ring

GENERAL TOLERANCE		ANGLE TOLERANCE	
.X	±0.60	.X	±5°
.X	±0.38	.X	±3°
.XX	±0.25	.XX	±2°
DRAWING TYPE		CUSTOMER	
SCALE	1:1	SHEET	1 OF 1
DRAWING NO.	C-DS1144- 49-XXXXXX-A		

PROJECTION		TITLE	USB C Type 12P Female SMT Type L=7.65mm Waterproof Grade IP-X7
UNITS	mm	SERIES	DS1144- 49 SERIES
SHEET SIZE	A4		

晨翔电子有限公司
CONNPLY CONNPLY ELECTRONIC CO. LTD