

No.: RD20210315006

TO: Ozdisan

APPROVAL SHEET No. : B-7602A

Series No.: KLH

Specification No.: add black

Halogen-Free Rohs2.0

APPROVAL SHEET

FOR AL. ELECTROLYTIC CAPACITORS

No.	(Customer No.)	(Koshin Part No.)	Description	ΦD x L
1		PKLH-016V332MH250	16V3300μF	12.5X25

APPROVED BY:

PLEASE SIGN RETURN US ONE COPY OF THE APPROVAL SHEET

DESIGNED BY: KUANGFEIFEI CHECKED BY: JIANGYUANYUAN APPROVED BY: HUANGXUEHUI

DATE: 2021-3-15

KOSHIN

DJS-SD-0013

Standard Size map:

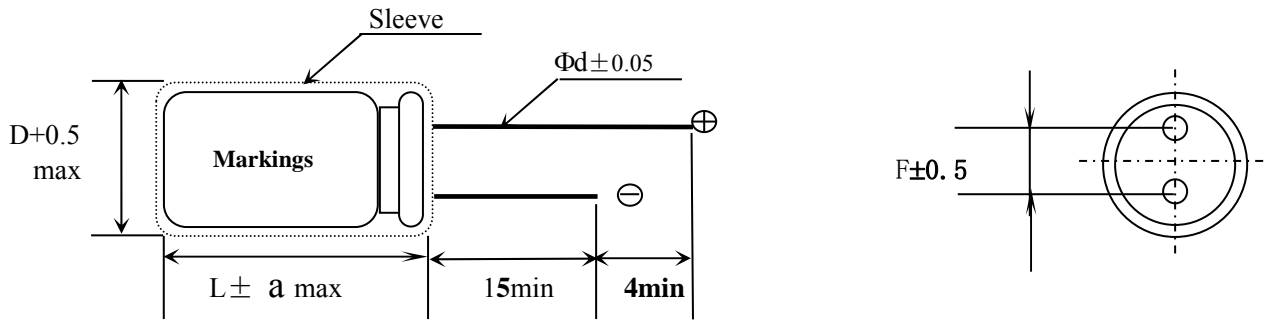

ΦD	12.5
F	5.0
Φd	0.6
L	25
a	2.0

Efficient of Frequency for Ripple Current

Frequency (Hz) \ Capacitance(μF)	Frequency (Hz)				
	50•60	120	1K	10K	100K
$CAP \leq 10$	0.47	0.59	0.85	0.97	1.00
$10 < CAP \leq 100$	0.52	0.65	0.89	0.97	1.00
$100 < CAP \leq 1000$	0.58	0.72	0.90	0.98	1.00
$CAP > 1000$	0.63	0.78	0.90	0.98	1.00

Coefficient of Temperature for Ripple Current

Temperature (°C)	45	60	85	95	105
Coefficient	2.10	1.90	1.65	1.25	1.00



Series KLH Capacitor

1. Our part No. :

For example :

<u>PKLH</u> -	<u>016V</u>	<u>332</u>	<u>M</u>	<u>H250</u>
Series code	rated voltage	capacitance	tolerance	case size symbol
PKLH	16v	3300 μ F	$\pm 20\%$	$\Phi 12.5 \times 25$

2. Your part No.:

3. Marking:

Include company's brand "Koshin", series code, rated voltage, capacitance, rated temperature range, polarity and tolerance of capacitance.

4. Specifications:

4.1 Temperature range :6.3V-100V: -40~+105°C ; 160V-600V: -25~+105°C ;

4.2 Electrical characteristics

4.2.1 Capacitance tolerance : $\pm 20\%$

4.2.2 Tangent of loss angle ($\tan \delta$) :

Rated voltage(V)	6.3	10	16	25	35	50	63	100	160
$\tan \delta$ (max.)	0.22	0.19	0.16	0.14	0.12	0.10	0.09	0.08	0.15

Rated voltage(V)	200	250	350	400	450	500	600
$\tan \delta$ (max.)	0.15	0.15	0.15	0.15	0.15	0.15	0.25

4.2.3 Leakage current (μ A) :

Rated voltage	6.3-100	160-600
Leakage current (μ A)	Less than 0.01CV or 3 whichever is large (after 2 minutes)	Less than 0.03CV (after 2 minutes)

Note: I : Leakage current (μ A) , C : Capacitance (μ F) , V : Rated DC working voltage (V)

1. Scope:

This specification applies to aluminium electrolytic capacitor, used in electronic equipment.

2. Electrical characteristics:

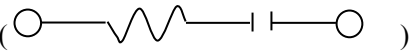
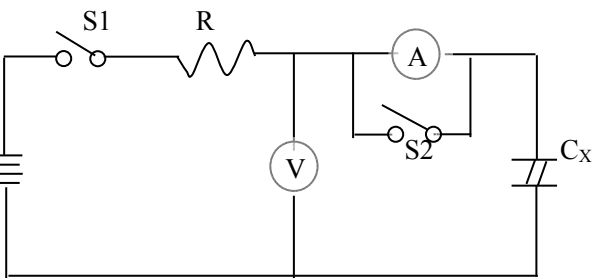
NO.	ITEM	TEST METHOD			SPECIFICATION 规格														
2.1	Rated voltage				Voltage range、capacitance range, see specification of this series														
2.2	Capacitance	1. Measuring frequency: 120Hz ± 12Hz																	
2.3	Dissipation factor	2. Measuring voltage: ≤ 0.5Vrms + 0.5VDC ~ 2.0VDC 3. Measuring circuit: 																	
2.4	Leakage current	DC leakage current shall be measured after 1~2minutes application of the DC rated working voltage through the 1000 Ω resistor at 20℃  R: 1000 Ω 100 Ω A: DC current meter V: DC voltage meter S1: Switch 开关 S2: Switch for protect of current meter C _x : Testing capacitor			Dissipation factor, leakage current, see specification of this series.														
2.5	Temperature characteristics	<table border="1"> <thead> <tr> <th data-bbox="339 1476 419 1518">STEP</th> <th data-bbox="419 1476 874 1518">TEMPERATURE</th> <th data-bbox="874 1476 1142 1518">STORAGE TIME</th> </tr> </thead> <tbody> <tr> <td data-bbox="339 1518 419 1554">1</td> <td data-bbox="419 1518 874 1554">20℃ ± 2℃</td> <td data-bbox="874 1518 1142 1554">30minutes</td> </tr> <tr> <td data-bbox="339 1554 419 1590">2</td> <td data-bbox="419 1554 874 1590">-40℃ ± 3℃、-25℃ ± 3℃</td> <td data-bbox="874 1554 1142 1590">2hours</td> </tr> <tr> <td data-bbox="339 1590 419 1626">3</td> <td data-bbox="419 1590 874 1626">20℃ ± 2℃</td> <td data-bbox="874 1590 1142 1626">15minutes</td> </tr> <tr> <td data-bbox="339 1626 419 1666">4</td> <td data-bbox="419 1626 874 1666">105℃ ± 2℃</td> <td data-bbox="874 1626 1142 1666">2hours</td> </tr> </tbody> </table>	STEP	TEMPERATURE		STORAGE TIME	1	20℃ ± 2℃	30minutes	2	-40℃ ± 3℃、-25℃ ± 3℃	2hours	3	20℃ ± 2℃	15minutes	4	105℃ ± 2℃	2hours	<p>Step1. Measure the capacitance and impedance.</p> <p>(Z , -40℃, -25℃ 120Hz ± 10%)</p> <p>Step2. Measure the impedance at thermal balance after 2 hours.</p> <p>(Z , -40℃, -25℃ 120Hz ± 10%)</p> <p>Step4. Measure the capacitance at thermal balance after 2 hours.</p>
STEP	TEMPERATURE	STORAGE TIME																	
1	20℃ ± 2℃	30minutes																	
2	-40℃ ± 3℃、-25℃ ± 3℃	2hours																	
3	20℃ ± 2℃	15minutes																	
4	105℃ ± 2℃	2hours																	

NO	ITEM	TEST METHOD	SPECIFICATION
2.6	Surge test	Rated surge voltage shall be applied (switch on)for 30±5 second and then shall be applied (switch off) with discharge for 5.5min at room temperature. This cycle shall be repeated for 1000 cycles. Duration of one cycle is 6±0.5 minutes	<p>Capacitance change: within±15% of the initial specified value.</p> <p>Dissipation factor: Less than specified value.</p> <p>Leakage current: Within initial specified value.</p>

3. Mechanical characteristics:

NO	ITEM	TEST METHOD	SPECIFICATION																
3.1	Lead strength	<p>(A)Tensile strength: wire lead terminal:</p> <table border="1" style="margin-left: 20px; border-collapse: collapse; text-align: center;"> <tr> <td style="padding: 2px;">d(mm)</td> <td style="padding: 2px;">≤0.5</td> <td style="padding: 2px;">0.5<d≤0.8</td> <td style="padding: 2px;">0.8<d≤1.25</td> </tr> <tr> <td style="padding: 2px;">load(kg)</td> <td style="padding: 2px;">0.5</td> <td style="padding: 2px;">1.0</td> <td style="padding: 2px;">2.0</td> </tr> </table> <p>The capacitor shall withstand the constant tensile force specified between the body and each lead for 10seconds without damage either mechanical or electrical.</p> <p>(B) Bending strength: wire lead terminal:</p> <table border="1" style="margin-left: 20px; border-collapse: collapse; text-align: center;"> <tr> <td style="padding: 2px;">d(mm)</td> <td style="padding: 2px;">≤0.5</td> <td style="padding: 2px;">0.5<d≤0.8</td> <td style="padding: 2px;">0.8<d≤1.25</td> </tr> <tr> <td style="padding: 2px;">load(kg)</td> <td style="padding: 2px;">0.5</td> <td style="padding: 2px;">0.5</td> <td style="padding: 2px;">1.0</td> </tr> </table> <p>with the capacitor in a vertical position apply the load specified axially to each lead. The capacitor shall be rotated slowly from the vertical to the horizontal position, back to the vertical position. The 90° in the opposite direction and back the original position. Performance of capacitor shall not have change and leads shall be undamaged.</p>	d(mm)	≤0.5	0.5<d≤0.8	0.8<d≤1.25	load(kg)	0.5	1.0	2.0	d(mm)	≤0.5	0.5<d≤0.8	0.8<d≤1.25	load(kg)	0.5	0.5	1.0	<p>When the capacitance is measured, there shall be no intermittent contacts, or open-or short-circuiting.</p> <p>There shall be no such mechanical damage as terminal damage etc. Capacitance change: within ± 5% of the initial specified value.</p>
d(mm)	≤0.5	0.5<d≤0.8	0.8<d≤1.25																
load(kg)	0.5	1.0	2.0																
d(mm)	≤0.5	0.5<d≤0.8	0.8<d≤1.25																
load(kg)	0.5	0.5	1.0																

NO.	ITEM	TEST METHOD	SPECIFICATION
3.2	Vibration resistance	The frequency of the vibration shall vary uniformly within the range 10 to 55 Hz with the amplitude of 0.75mm, completing the cycle in the interval of one minute. The capacitor shall be securely mounted by its leads with hold the body of capacitor. The capacitor shall be vibrated in three mutually perpendicular directions for a period of 2 hours in each direction.	Appearance : no abnormal. Capacitance change: within $\pm 5\%$ of initial measured value.
3.3	Solder ability	The leads are dipped in the solder bath of Sn at $245^{\circ}\text{C} \pm 5^{\circ}\text{C}$ for 2 ± 0.5 seconds. The dipping depth should be set at 1.5~2.0 mm.	The solder alloy shall cover the 95% or more of dipped lead's area.

4. Reliability:

NO.	ITEM	TEST METHOD	SPECIFICATION
4.1	Soldering heat resistance	The leads immerse in the solder bath of Sn at $260^{\circ}\text{C} \pm 5^{\circ}\text{C}$ for 10 ± 1 seconds until a distance of 1.5~2.0mm from the case.	No visible damage or leakage of electrolyte. Capacitance change: Within $\pm 5\%$ of the initial measured value Tan δ : Less than specified value. Leakage current: Less than specified value
4.2	Damp head (steady state)	Subject the capacitor to $40^{\circ}\text{C} \pm 2^{\circ}\text{C}$ and 90% to 95% relative humidity for 504 hours.	Capacitance change: Within $\pm 20\%$ of the initial measured value Tan δ : Less than 1.2 specified value. Leakage current: Less than specified value Impedance: Less than 1.2 specified value.

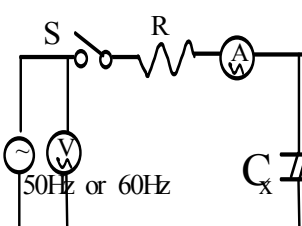
NO	ITEM	TEST METHOD	SPECIFICATION														
4.3	Load life	After 5000 hours continuous application of max allowable ripple current and DC rated voltage at $105\text{ }^{\circ}\text{C} \pm 2\text{ }^{\circ}\text{C}$, Measurements shall be performed after 16 hours exposed at room temperature.	Capacitance change: Within $\pm 20\%$ of the initial value. Tan δ :less than 200% specified value														
4.4	Shelf life	After storage for 1000 hours at $105\text{ }^{\circ}\text{C} \pm 2\text{ }^{\circ}\text{C}$ without voltage application ,Measurements shall be performed after exposed for 16 hrs at room temperature after application of Testing	Leakage current: Less than initial specified value. Appearance :no Abnormal														
4.5	Storage at low temperature	The capacitor shall be stored at temperature of $-40\text{ }^{\circ}\text{C} \pm 3\text{ }^{\circ}\text{C}$ for 16 hours, during which time be subjected to standard atmospheric conditions for 16 hours or more. After which measurements shall be made.	Capacitance change: Within $\pm 10\%$ of the initial value. Tan δ :less than specified value Leakage current: Less than specified value. Appearance: no Abnormal.														
4.6	Pressure relief	AC test: Applied voltage: AC voltage not exceeding 0.7 times of the rated direct voltage or 250V AC whichever is the lower. Frequency : 50Hz or 60Hz. Series resistor :refer to the table below <table border="1" style="margin-left: auto; margin-right: auto; border-collapse: collapse; text-align: center;"> <thead> <tr> <th>Capacitance(C)</th> <th>Series resistor</th> </tr> </thead> <tbody> <tr> <td>$C < 1\text{ }\mu\text{F}$</td> <td>$1000\text{ }\Omega$</td> </tr> <tr> <td>$1\text{ }\mu\text{F} < C \leq 10\text{ }\mu\text{F}$</td> <td>$100\text{ }\Omega$</td> </tr> <tr> <td>$10\text{ }\mu\text{F} < C \leq 100\text{ }\mu\text{F}$</td> <td>$10\text{ }\Omega$</td> </tr> <tr> <td>$100\text{ }\mu\text{F} < C \leq 1000\text{ }\mu\text{F}$</td> <td>$1\text{ }\Omega$</td> </tr> <tr> <td>$1000\text{ }\mu\text{F} < C \leq 10000\text{ }\mu\text{F}$</td> <td>$0.1\text{ }\Omega$</td> </tr> <tr> <td>$10000\text{ }\mu\text{F} < C$</td> <td>*</td> </tr> </tbody> </table> * Resistance is equivalent to a half impedance by test frequency.	Capacitance(C)	Series resistor	$C < 1\text{ }\mu\text{F}$	$1000\text{ }\Omega$	$1\text{ }\mu\text{F} < C \leq 10\text{ }\mu\text{F}$	$100\text{ }\Omega$	$10\text{ }\mu\text{F} < C \leq 100\text{ }\mu\text{F}$	$10\text{ }\Omega$	$100\text{ }\mu\text{F} < C \leq 1000\text{ }\mu\text{F}$	$1\text{ }\Omega$	$1000\text{ }\mu\text{F} < C \leq 10000\text{ }\mu\text{F}$	$0.1\text{ }\Omega$	$10000\text{ }\mu\text{F} < C$	*	AC test circuit  Ⓢ : AC power S : Switch Ⓢ : AC voltage meter Ⓢ : AC current meter R : protection resistor C _x : testing capacitor
Capacitance(C)	Series resistor																
$C < 1\text{ }\mu\text{F}$	$1000\text{ }\Omega$																
$1\text{ }\mu\text{F} < C \leq 10\text{ }\mu\text{F}$	$100\text{ }\Omega$																
$10\text{ }\mu\text{F} < C \leq 100\text{ }\mu\text{F}$	$10\text{ }\Omega$																
$100\text{ }\mu\text{F} < C \leq 1000\text{ }\mu\text{F}$	$1\text{ }\Omega$																
$1000\text{ }\mu\text{F} < C \leq 10000\text{ }\mu\text{F}$	$0.1\text{ }\Omega$																
$10000\text{ }\mu\text{F} < C$	*																

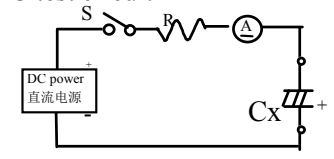
NO.	ITEM	TEST METHOD	SPECIFICATION
4.6	Pressure relief	<p>DC test Send the following electricity while applying the inverse voltage.</p> <p>Where case size $D \leq 22.4\text{mm}$: 1 A d.c.max $D > 22.4\text{mm}$: 10 A d.c.max</p> <p>Note: 1. This requirement applies to capacitors with a diameter of 6 mm or more. 2. When the pressure relief device does not open even 30 minutes after commencement of test, the test may be ended.</p>	<p>DC test circuit</p>  <p>S : Switch Ⓐ : DC current meter C x : testing capacitor</p> <p>The pressure relief device shall open in such a way as to avoid any damage of fire or explosion of capacitor elements (terminal and metal foil etc.) or cover.</p>
4.7	Temp cycle	<p>LSL temperature(°C):-40 ± 3 time(H): 0.5H/timeX5 times USL temperature(°C):105 ± 2 time(H): 0.5H/timeX5 times Judgement: CAP: $\Delta C/C \leq \pm 10\%$, Appearance no Abnormal. No electrolyte leakage.</p>	
4.8	Thermal shock	<p>dry heat temperature (°C): 105 ± 2 time(H): 16 moist heat temperature(°C): 55 time(H): 24/ cold temperature(°C): -40 ± 2 time(H): 2/ moist heat temperature(°C): 55 time(H): 24 : Judgement: CAP, $\Delta C/C \leq \pm 10\%$, Tan δ :Less than 1.2 specified value, Leakage current: Less than specified value. Appearance no Abnormal. No electrolyte leakage.</p>	

5. Marking

Marking on capacitors include:

Koshin trade-mark

Koshin
Working voltage

Normal capacitance

Tolerance

Polarity

Operating temperature range

Sleeving pipe basic: Coffee PET

Printing color: White

Required space above the valve (mm): 2.0mm

Detergent needing attention

Hydrogen carbide liquid and halogen liquid can cause Aluminium Electrolytic Capacitor to corrode. Some of Safe and Unsafe detergent are as follows

Safe	Unsafe
Dimethylbenzene	1,1,2-trichloroethane
Ethanol	1,2,2- trichloroethane
Butanol	Tetrachloroethylene
Methanol	Chloroform(colorless volatilizable liquid)
Propanol	Dichloromethane
Detergent	Trichloroethylene

Aluminum Electrolytic Capacitor Specification

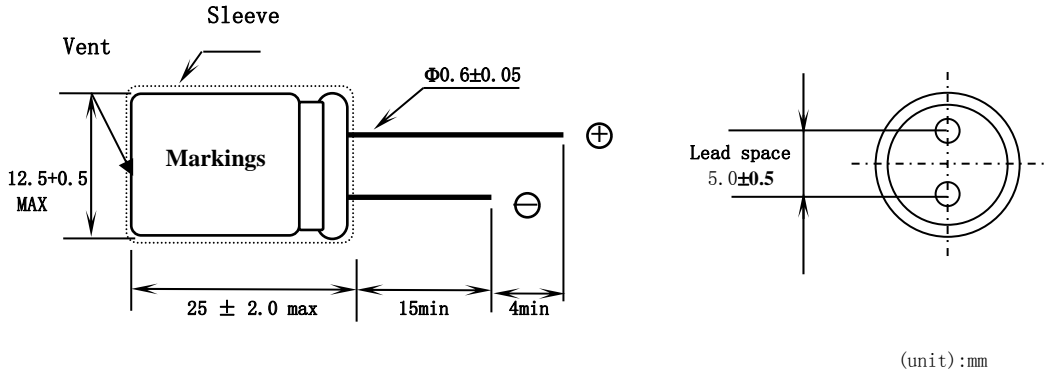
Series	PKLH	16 V 3300 μ F	Part No.	PKLH-016V332MH250
Customer No.	/		Case size	Φ D12.5 X L25
Specification	Items		Standard	
	Operating temperature range		- 40 ~ + 105 $^{\circ}$ C	
	Capacitance tolerance		\pm 20% (20 $^{\circ}$ C , 120Hz)	
	Dissipation factor (MAX)		(Less than) 20% (20 $^{\circ}$ C , 120Hz)	
	Leakage current (MAX)		(Less than) 528 μ A (20 $^{\circ}$ C 16V 2 min)	
	Impedance (MAX)		0.028 Ω (100KHz , 20 $^{\circ}$ C)	
	Ripple current (MAX)		2340 mArms (100KHz , 105 $^{\circ}$ C)	
	Load life		5000 hrs	
Outline	Sleeve color		Coffee PET	
	Marking color		White	
	(Dimensions)			
	Copper clad steel wire(tinned)			
				
Recorder	(The first edition) :2021-3-15			
Wrote by: Kuangfeifei		Checked by: Jianguanyuan		Approved by: Huangxuehui