

Features

- Evaluation platform for RPL-3.0 Buck Regulator Module
- Thermal design considerations included
- EMI Class A filter
- Easy evaluation of output voltage selection, control, power good and sensing functions

Evaluation Module

Description

The RPL-3.0-EVM-1 generates a constant output voltage selectable from 1.8V, 3.3V, or 5V from a DC input in the range of 4 – 18V. It has a maximum continuous output current of 3 A.

All the functions of the RPL-3.0 such as output voltage selection, control, power good, and output sense can be readily evaluated. Also the behavior in overload or over-temperature can be evaluated easily before it is designed in.

The evaluation board also contains the filter components to meet EMC Class A levels. Alternate component positions are included to allow experimentation to optimize the EMC performance depending on operating conditions and budget.

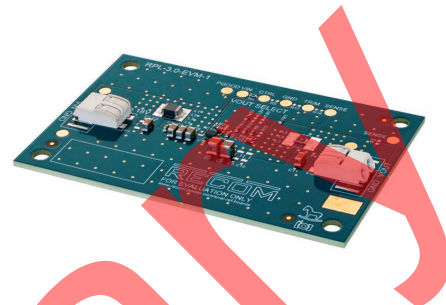

Selection Guide

Part Number	Input Voltage Range [VDC]	Output Voltage ⁽¹⁾ [VDC]	Output Current max. [A]
RPL-3.0-EVM-1	4.0 - 18	1.8	3
	4.5 - 18	3.3	
	6.5 - 18	5	

Notes:

Note1: refer to [SAFE OPERATING AREA](#) of RPL-3.0 datasheet

Quick Start Guide

1. Connect P3 to power supply (observe correct polarity!)
2. Connect P4 to the load (no load operation is allowed)
3. The evaluation module is preset to 5Vout. The output voltage can be selected with values of 1.8V, 3.3V, and 5V by shorting a 0Ω resistor to the respective places as seen in the board silkscreen.
4. The sense pin is connected to the RPL output pin, so the preset voltage is very accurate at the output of the RPL. To compensate any losses of the filter, remove the resistor at R1, and solder a zero ohm resistor at R3.
5. CTRL
The device is preset as normally on. It can be disabled by pulling the CTRL pad to GND. Short R5 to disable the device.



Caution:

ESD sensitive. Always follow ESD preventative procedures when handling the product!

Specifications (measured @ Ta= 25°C, full load and after warm-up unless otherwise stated)

Component Placement

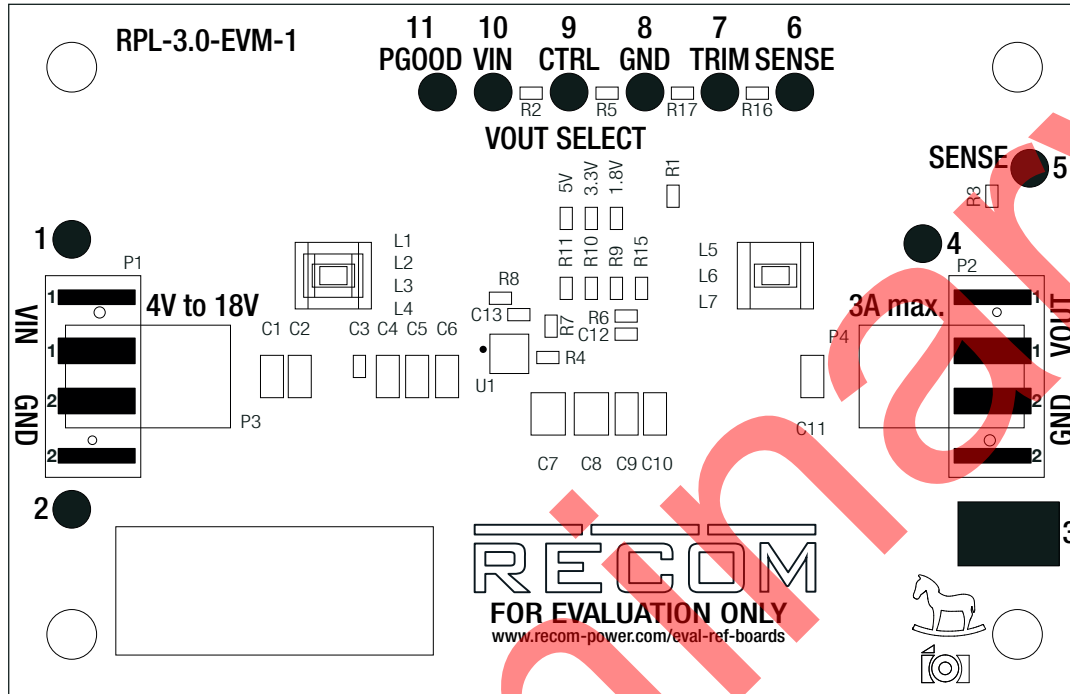

Connector Description

P1 (Not Mounted)

Pin	Name	Description
1	NC	No Connection
2	NC	No Connection

P2 (Not Mounted)

Pin	Name	Description
1	NC	No Connection
2	NC	No Connection

P3

Pin	Name	Description
1	VIN	Positive Input Voltage (observe correct polarity!)
2	GND	Common GND

P4

Pin	Name	Description
1	VOUT	Positive Output Voltage
2	GND	Common GND

Pads Direct Connection

Pin	Name	Description
1	VIN	Positive Input Voltage
2	GND	Negative Input Voltage (GND)
3	GND	Negative Output Voltage (GND)
4	VOUT	Positive Output Voltage
5,6	SENSE	Output Voltage Sense Pin (leave open if not used)
7	TRIM	TRIM Pad (leave open if not used)
8	GND	Negative Input Voltage (GND)
9	CTRL	CTRL Pad (leave open if not used)
10	VIN	Positive Input Voltage
11	PGOOD	Power Good Signal

Schematic

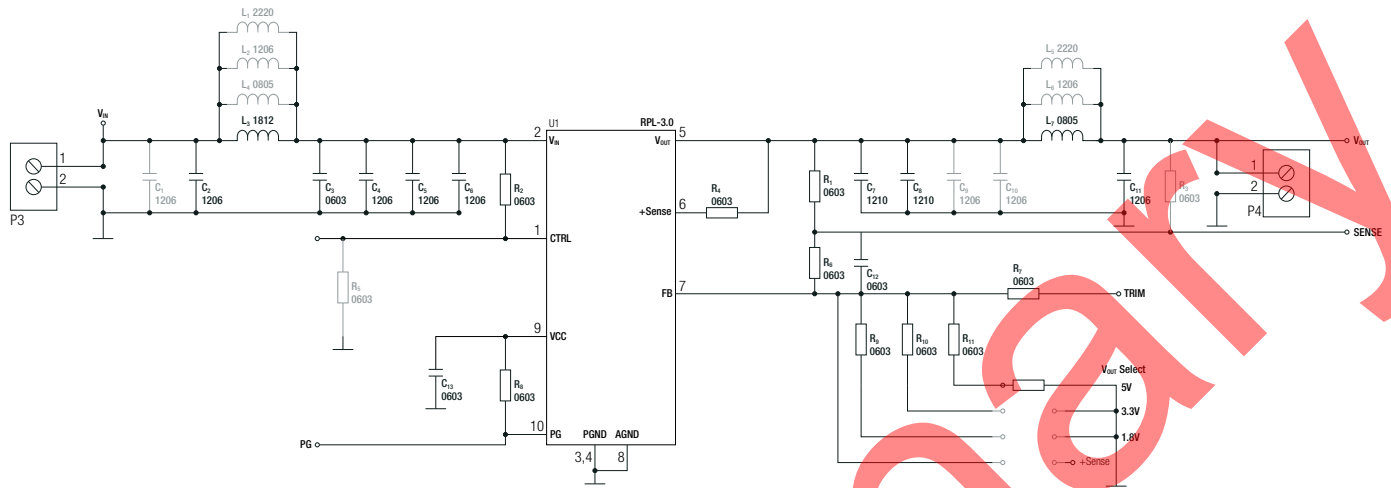

Notes:

Note2: Gray colored components are not mounted

Description

U1: RPL-3.0 power module.

C1,C2,L1,L2,L3,L4,C3,C4,C5,C6: allow placement of various sized components to test input filter design. The populated filter is designed to meet EN55022 class A. Note: Connect a 220uF across the input for damping the LISN.

C7,C8,C9,C10,L5,L6,L7,C11: allow placement of various sized components to test output filter design. The populated filter is designed to meet EN55022 class A. Note: Connect a 220uF across the input for damping the LISN.

R2 and R5: configure CTRL. R2 is populated to enable the RPL-3.0. Short R5 in order to disable the RPL-3.0.

R1: populated zero ohm resistor for direct output voltage measurement. If sense is desired at a different location, for example after the filter or directly at the load, unsolder R1, and connect sense to the new measurement point.

R3: sense point for output voltage after the filter. To set sense point here, remove R1 and solder a zero ohm resistor at R3.

VOUT Selection: the output voltage can be selected with values of 1.8V, 3.3V, and 5V by shorting a zero ohm resistor to the respective places as seen in the board silkscreen.

R16, R17: trim the output voltage. Refer to **"OUTPUT VOLTAGE TRIMMING"**

OUTPUT VOLTAGE TRIMMING

The RPL-3.0 offers the feature of trimming the output voltage by using external trim resistors. The values for trim resistors are shown in trim tables below according to E96 values; therefore, the specified voltage may slightly vary. Refer to *"Selection Guide"* for applicable Vout range.

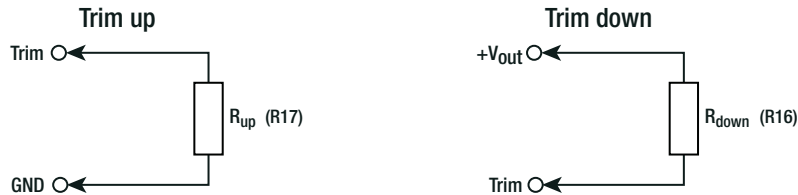

Calculation:

- Vout_{nom} = nominal output voltage [VDC]
- Vout_{set} = trimmed output voltage [VDC]
- V_{ref} = reference voltage [VDC]
- R_{up} = trim up resistor [kΩ]
- R_{down} = trim down resistor [kΩ]
- R_{Hi}, R_{Lo} = internal resistors [kΩ]

R _{Hi}	R _{Lo}	V _{ref}
37k6Ω	47kΩ	0.8VDC

$$R_{up} = \left[\frac{R_{Hi}}{V_{out_set} - V_{nom}} \right] - 1k$$

$$R_{down} = \left[\frac{(V_{out_set} - V_{ref}) \times R_{Lo}}{V_{out_nom} - V_{set}} \right]$$

Practical Example, trim up:

Vout_{set} = 5.1VDC

$$R_{up} = \left[\frac{37k6\Omega}{5.1 - 5} \right] - 1k = \underline{376k\Omega}$$

R_{up} according to E96 ≈ 374kΩ

Practical Example, trim down:

Vout_{set} = 4VDC

$$R_{down} = \left[\frac{(4 - 0.8) \times 47k\Omega}{5 - 4} \right] = \underline{150k4\Omega}$$

R_{down} according to E96 ≈ 150kΩ

Vout_{set} = 1.8V

Trim up

Vout _{set} =	1.82	1.88	1.90	1.98	[VDC]
R _{up} (E96) ≈	1M87	464k	374k	210k	[Ω]

Trim down

Vout _{set} =	1.7	1.6	1.5	1.44	[VDC]
R _{down} (E96) ≈	422k	187k	110k	84k5	[Ω]

Vout_{set} = 3.3V

Trim up

Vout _{set} =	3.4	3.5	3.6	3.63	[VDC]
R _{up} (E96) ≈	374k	187k	124k	113k	[Ω]

Trim down

Vout _{set} =	3.1	3	2.8	2.64	[VDC]
R _{down} (E96) ≈	536k	340k	187k	130k	[Ω]

Vout_{set} = 5V

Trim up

Vout _{set} =	5.1	5.2	5.3	5.5	[VDC]
R _{up} (E96) ≈	374k	187k	124k	75k	[Ω]

Trim down

Vout _{set} =	4.7	4.5	4.3	4	[VDC]
R _{down} (E96) ≈	619k	348k	237k	150k	[Ω]

Specifications (measured @ Ta= 25°C, full load and after warm-up unless otherwise stated)

DIMENSION AND PHYSICAL CHARACTERISTICS

Parameter	Type	Value
Dimension (LxWxH)		85.0 x 55.0 x 6.5mm
Weight		21.2g typ.

Layout

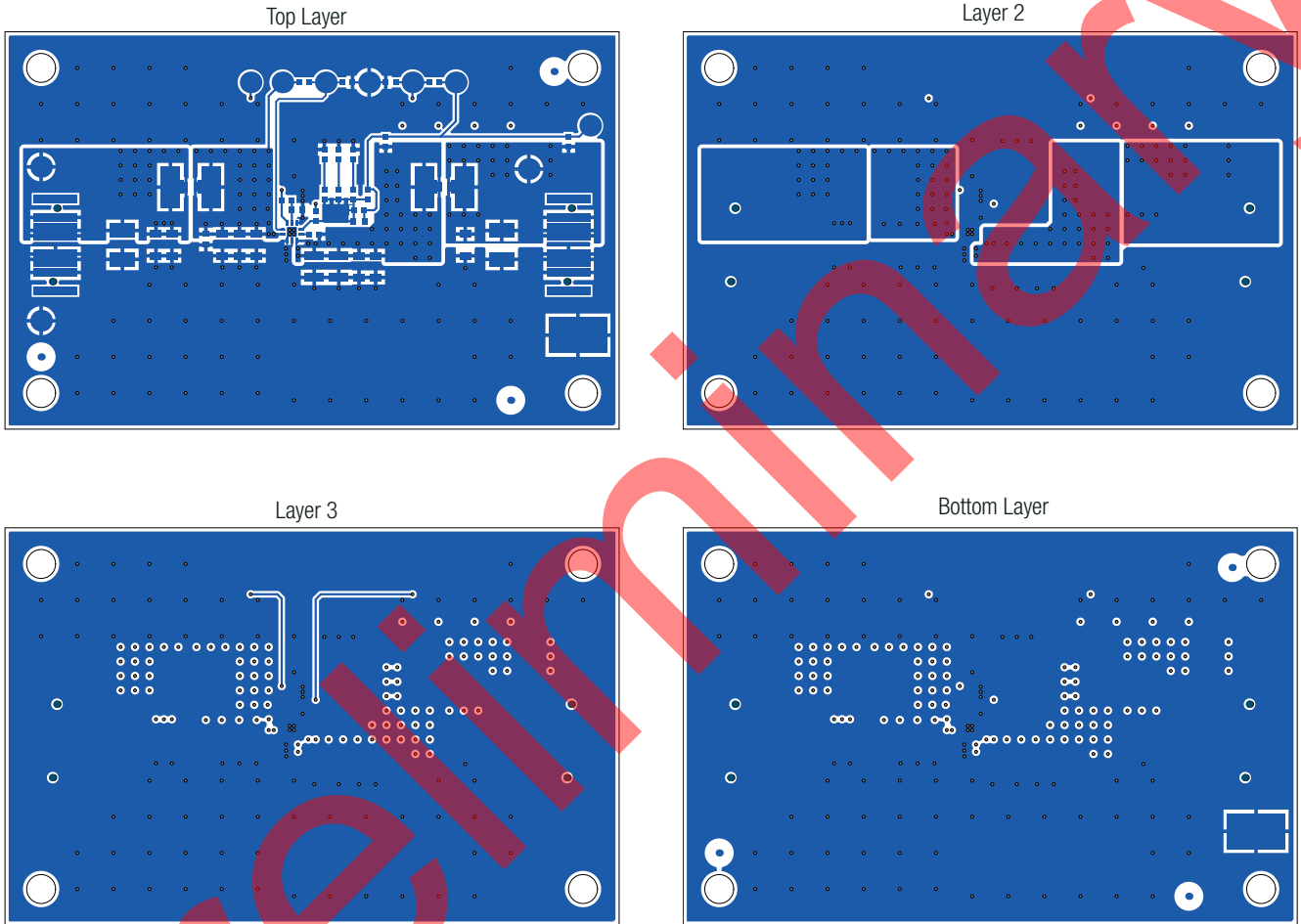

Notes:

Note3: Visit www.recom-power.com/eval-ref-boards to download the Gerber files

BOM

Comp.	Description	Manufacturer Part Number	Manufacturer	Remarks
C1	10µF 25V X7R 1206	CL31B106KAHNNNE	Samsung Electro-Mechanics	not mounted
C2	10µF 25V X7R 1206	CL31B106KAHNNNE	Samsung Electro-Mechanics	
C3	100nF 25V X7R 0603	CL10B104KA8NNNC	Samsung Electro-Mechanics	
C4	10µF 25V X7R 1206	CL31B106KAHNNNE	Samsung Electro-Mechanics	
C5	10µF 25V X7R 1206	CL31B106KAHNNNE	Samsung Electro-Mechanics	
C6	10µF 25V X7R 1206	CL31B106KAHNNNE	Samsung Electro-Mechanics	
C7	22µF 16V X7R 1210	CL32B226KOJNNNE	Samsung Electro-Mechanics	

continued on next page

Specifications (measured @ Ta= 25°C, full load and after warm-up unless otherwise stated)

Comp.	Description	Manufacturer Part Number	Manufacturer	Remarks
C8	22µF 16V X7R 1210	CL32B226KOJNNNE	Samsung Electro-Mechanics	
C9	10µF 25V X7R 1206	CL31B106KAHNNNE	Samsung Electro-Mechanics	not mounted
C10	10µF 25V X7R 1206	CL31B106KAHNNNE	Samsung Electro-Mechanics	not mounted
C11	10µF 25V X7R 1206	CL31B106KAHNNNE	Samsung Electro-Mechanics	
C12	100pF 25V X7R 0603	CC0603KRX7R8BB101	Yageo	
C13	1 µ F 16V X7R 0603	CL10B105K08NFNC	Samsung Electro-Mechanics	
L1	FERRITE BEAD 2220	HI2220R301R-10	Laird	not mounted
L2	FERRITE BEAD 1206	742792121	Würth	not mounted
L3	FERRITE BEAD 74279252	74279252	Würth	
L4	FERRITE BEAD 0805	742792040	Würth	not mounted
L5	FERRITE BEAD 2220	HI2220R301R-10	Laird	not mounted
L6	OR 1206	CRCW1206000Z0EAC	Vishay	
L7	OR 0805	RC0805JR-070RL	Yageo	not mounted
P1	CONNECTOR	XW4K-04A1-H1	Omron Electronics INC	not mounted
P2	CONNECTOR	XW4K-04A1-H1	Omron Electronics INC	not mounted
P3	CONNECTOR	2060-452_998-404	Wago	
P4	CONNECTOR	2060-452_998-404	Wago	
R1	OR 0.1W 0603	RC0603JR-070RL	Yageo	
R2	100K OHM 0.1W 1% 0603	RC0603FR-07100KL	Yageo	
R3	OR 0.1W 0603	RC0603JR-070RL	Yageo	not mounted
R4	1K OHM 0.1W 1% 0603	RC0603FR-071KL	Yageo	
R5	OR 0.1W 0603	RC0603JR-070RL	Yageo	not mounted
R6	47K OHM 0.1W 1% 0603	RC0603FR-0747KL	Yageo	
R7	1K OHM 0.1W 1% 0603	RC0603FR-071KL	Yageo	
R8	100K OHM 0.1W 1% 0603	RC0603FR-07100KL	Yageo	
R9	37K4 OHM 0.1W 1% 0603	RC0603FR-0737K4L	Yageo	
R10	15K OHM 0.1W 1% 0603	RC0603FR-0715KL	Yageo	
R11	8K87 0.1W 1% 0603	RC0603FR-078K87L	Yageo	
R12	OR 0.1W 0603	RC0603JR-070RL	Yageo	
R13	OR 0.1W 0603	RC0603JR-070RL	Yageo	not mounted
R14	OR 0.1W 0603	RC0603JR-070RL	Yageo	not mounted
R15	OR 0.1W 0603	RC0603JR-070RL	Yageo	not mounted
R16	OR 0.1W 0603	RC0603JR-070RL	Yageo	not mounted
R17	OR 0.1W 0603	RC0603JR-070RL	Yageo	not mounted
U1	RPL-3.0	RPL-3.0	RECOM	

PACKAGING INFORMATION

Parameter	Type	Value
Packaging Dimension (LxWxH)		114.0 x 60.0 x 28.0mm
Packaging Quantity		1pc

Contents

- RPL-3.0-EVM-1 Evaluation Module
- Terms and Conditions