

REV.	DESCRIPTION	DRAWN	DATE
5	ECR2000003	FROS	2020/04/16
5.1	ECR2000010	FROS	2020/07/24
5.2	ECR2100003	TIM	2021/01/27

SPECIFICATION:

1. ELECTRICAL
 - 1.1 Current Rating: 0.5A per pin
 - 1.2 Voltage Rating: 50V AC
 - 1.3 Contact Resistance: 55mΩ Max
 - 1.4 Insulation Resistance: 500MΩ Min
 - 1.5 Dielectric Withstanding Voltage: 300VAC
2. MECHANICAL
 - 2.1 Durability: 50 Cycles
 - 2.2 Total Mating/Unmating Force: 2.3Kgf max.
3. ENVIRONMENTAL
 - 3.1 Operating temperature range: -40°C ~ +85°C
 - 3.2 Storage temperature range: -40°C ~ +85°C
4. SOLDER ABILITY
 - 4.1 Recommended IR-Reflow Temperature: 260°C 10Sec

Date Code: Y WW D

Year | | Day(1~7)
Week(1~52)

3	HOLDDOWN	Brass, Tin plated under nickel plating	
2	CONTACT	Phosphor Bronze, contact area: G/F solder area: Tin, under plating Nickel	
1	HOUSING	LCP UL94V-0, Black	
NO. PART NAME		DESCRIPTION	
UNLESS OTHERWISE SPECIFIED TOLERANCE			
UNIT:	DECIMAL	LINEAR	ANGLES
mm	X.	±0.50	±5°
	X.X	±0.25	±3°
	X.XX	±0.12	±1°
DRAWN		Willis	2009/11/11
CHECKED		Angel	2009/11/11
APPROVED		Ken	2009/11/11
SCALE		2.25/1	
SHEET		1/2	
SIZE		A4	
DRAWN NAME:		Mini PCI Express Socket H: 5.6mm	
PRODUCT NO.		119A-56A00-R02	
FILE NAME		119A-56A00-R02_B_5.2	



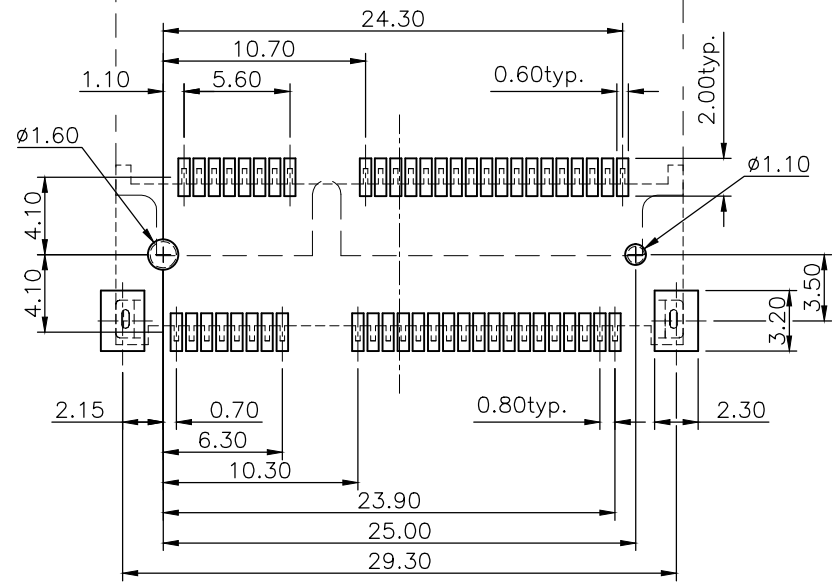
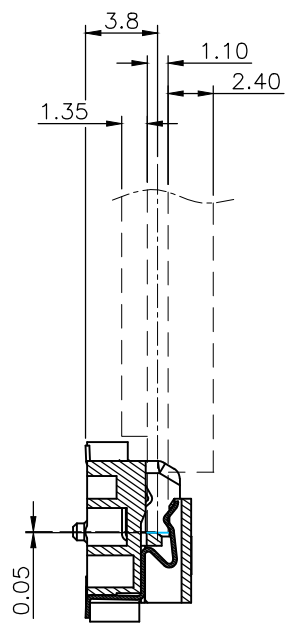

www.attend.com.tw

REV.	DESCRIPTION	DRAWN	DATE
	see sheet one		



--- CARD
 --- PAD LAYOUT

RECOMMEND LAYOUT (TOP VIEW)
GENERAL TOLERANCE: ±0.05

UNLESS OTHERWISE SPECIFIED TOLERANCE				 www.attend.com.tw	
UNIT:	DECIMAL	LINEAR	ANGLES		
mm	X.	±0.50	±5°		
	X.X	±0.25	±3°		
	X.XX	±0.12	±1°		
DRAWN	Willis	2009/11/11	DRAWN NAME:		
CHECKED	Angel	2009/11/11	Mini PCI Express Socket H: 5.6mm		
APPROVED	Ken	2009/11/11	PRODUCT NO.	119A-56A00-R02	
	SCALE	SHEET	SIZE	FILE NAME	
	2.25/1	2/2	A4	119A-56A00-R02_B_5.2	

REV.	DESCRIPTION	DRAWN	DATE
3	Note 9.2H 300 PCS/REEL	Willis	2010/04/30
4	New frame	Willis	2012/08/03
5	ECR2000003	FROS	2020/04/16

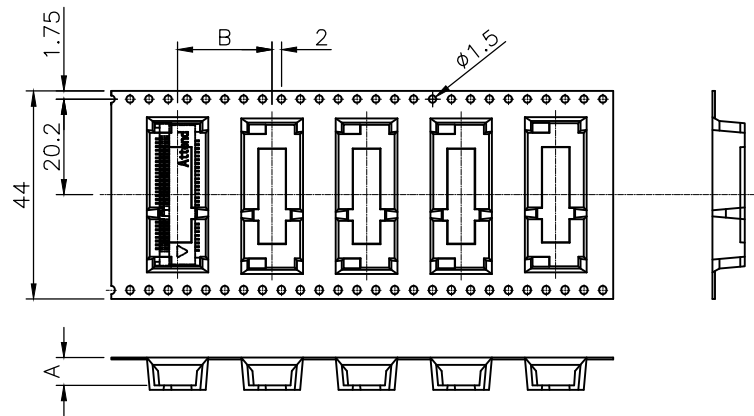
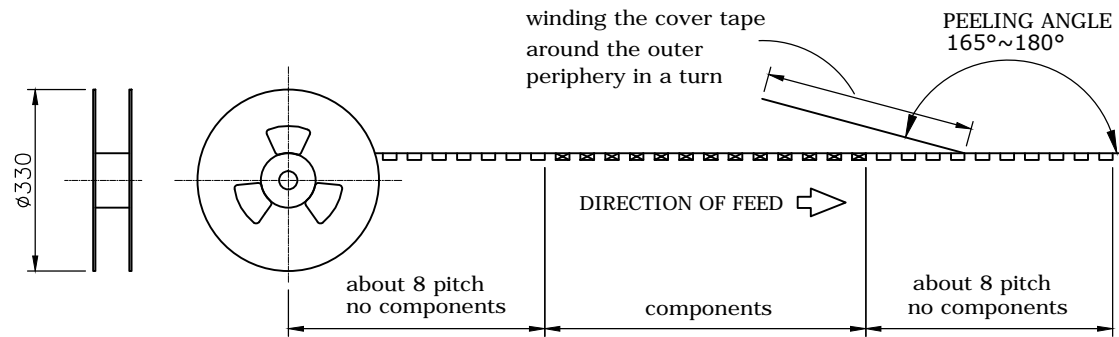

Dimension table:

P/N	DIM. A	DIM. B
119A-40A00-R02	4.30	16.00
119A-56A00-R02	5.90	16.00
119A-80A00-R02	8.30	16.00
119A-92A00-R02	9.50	20.00

PACKAGING SPECIFICATION:

1. MATERIAL

- 1.1 Embossed Carrier Tape: PS Black
- 1.2 Top Cover Tape: PET 20-80g (Peel Speed 300mm/Minute)
- 1.3 Taping Reel: Plastic

2. PACKING

2.1 Quantity:

P/N	PCS/ REEL	PCS/ CARTON
119A-40A00-R02	700	4200
119A-56A00-R02	550	3300
119A-80A00-R02	400	2400
119A-92A00-R02	300	1800

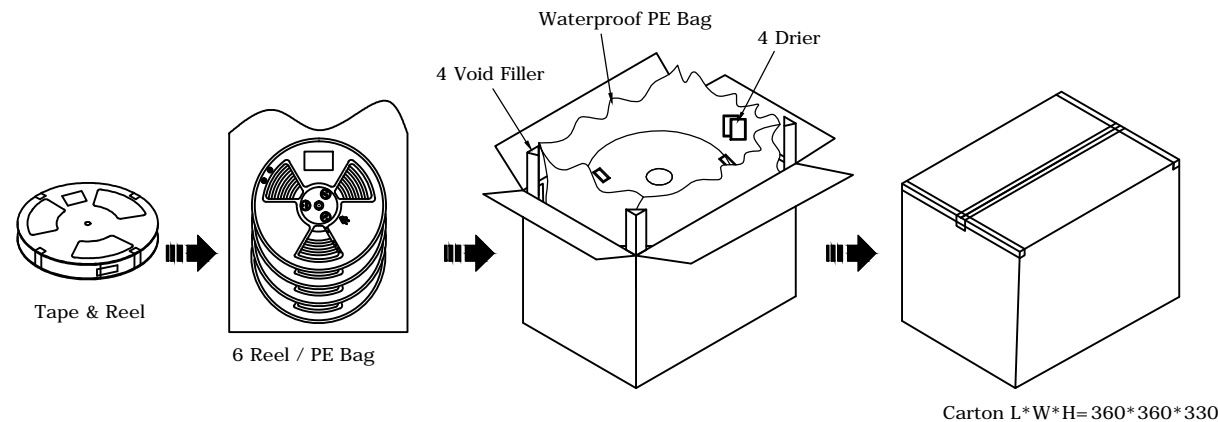

UNLESS OTHERWISE SPECIFIED TOLERANCE			
UNIT:	DECIMAL	LINEAR	ANGLES
mm	X.	±0.50	±5°
	X.X	±0.25	±3°
	X.XX	±0.12	±1°



www.attend.com.tw

DRAWN	Willis	2009/11/11	DRAWN NAME:	Mini PCI Express Socket Packaging drawing	
CHECKED	Angel	2009/11/11			
APPROVED	Ken	2009/11/11	PRODUCT NO.	see table	
SCALE	n/a	SHEET 1/1	SIZE A4	FILE NAME	119A-XXA00-R02_D_5

REV.	DESCRIPTION	DRAWN	DATE
1	Initial Release	FROS	2014/12/03

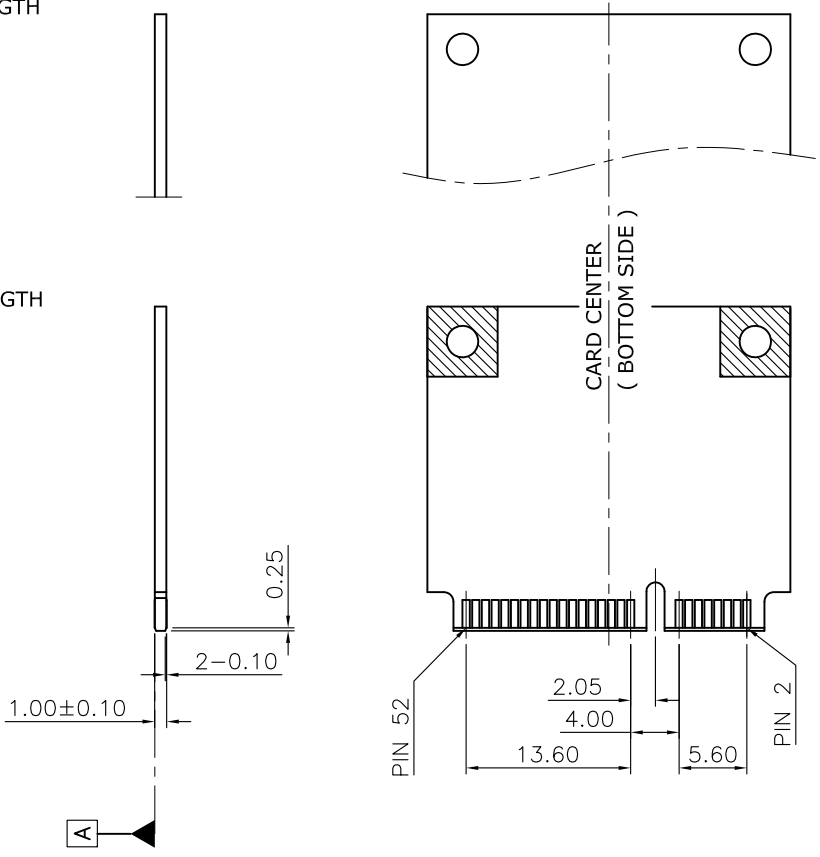
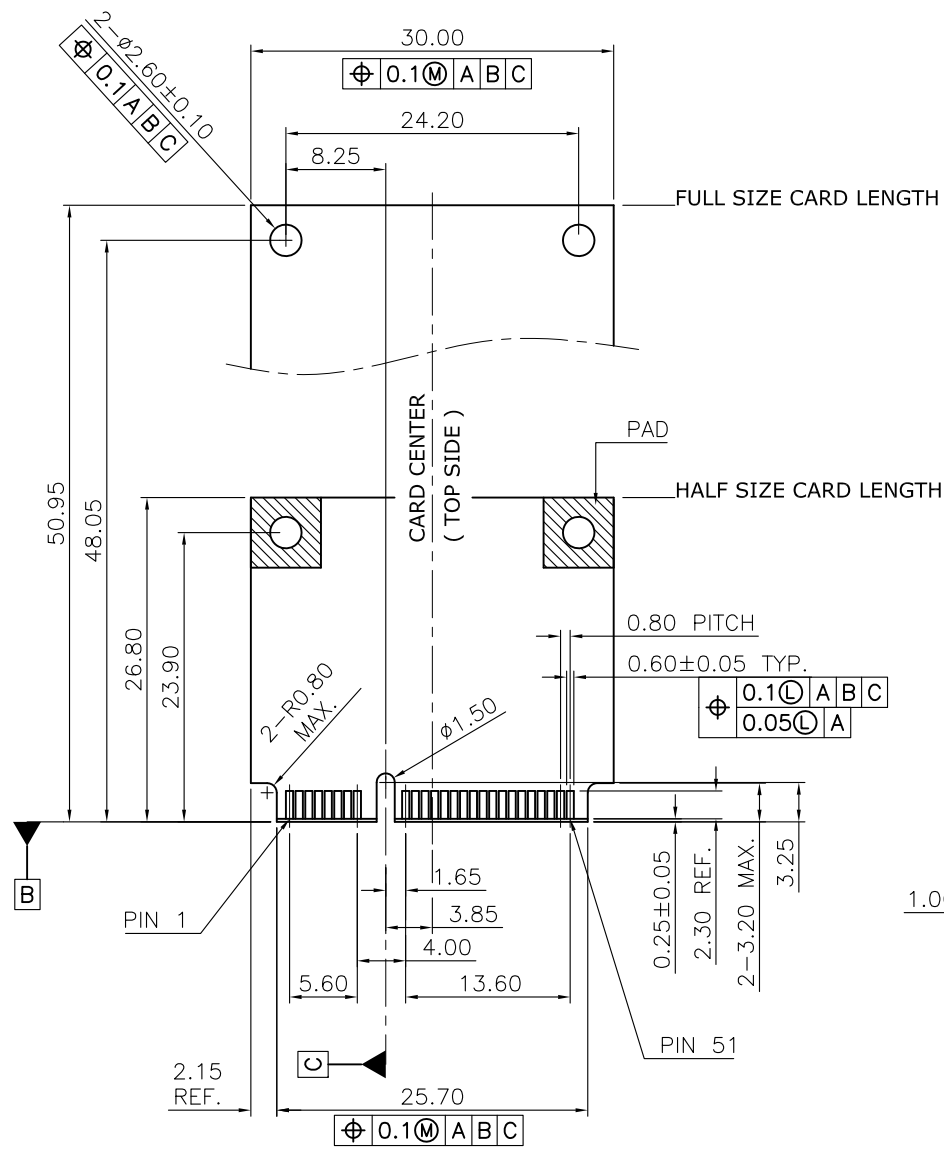

UNLESS OTHERWISE SPECIFIED TOLERANCE					
UNIT:	DECIMAL	LINEAR	ANGLES		
mm	X.	±0.50	±5°	WWW.ATTEND.COM.TW	
	X.X	±0.25	±3°		
	X.XX	±0.12	±1°		
DRAWN	Fros	2014/12/03	DRAWN NAME:		
CHECKED	Ron	2014/12/03	PHYSICAL DIMENSIONS OF		
APPROVED	Albert	2014/12/03	PCI EXPRESS MINI CARD		
SCALE	1.6/1	SHEET	1/1	SIZE	A4
PRODUCT NO.	FILE NAME				
					119A-CARD_1

REV.	DESCRIPTION	DRAWN	DATE
2	Revised frame	Willis	2013/01/25
3	Revised frame & p/n table	FROS	2017/06/14
4	ECR2000003	TIM	2020/04/24

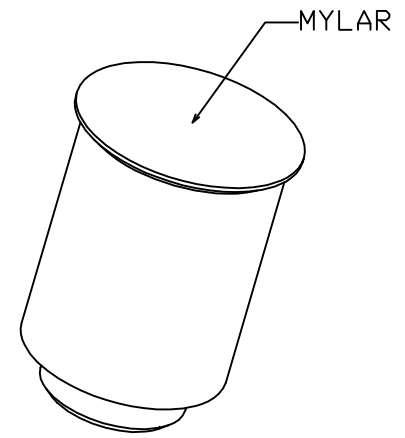
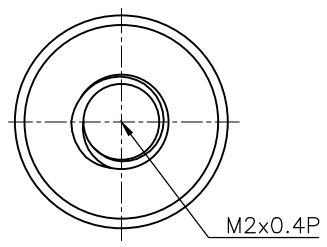

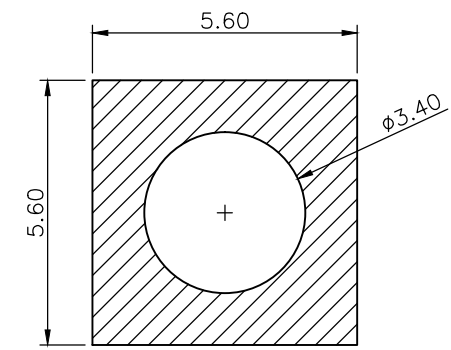
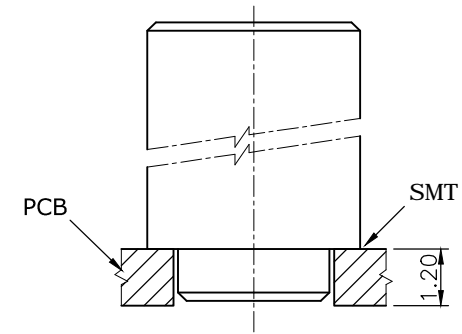
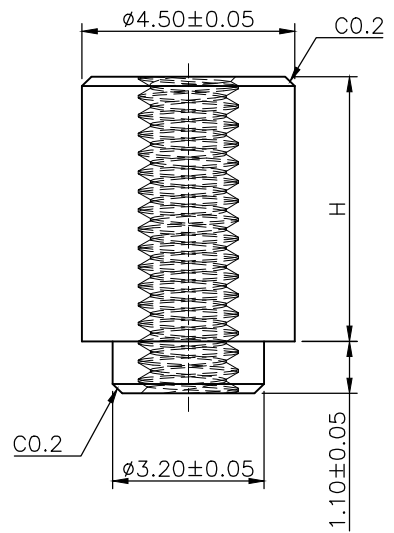

NOTE:
 1. MATERIAL: Copper Alloy
 2. Plating: Sn.



PCB Recommend Layout Pattern

NUT P/N	"H"±0.1	Mini PCI E P/N
119A-NUT-40-R02	1.6	119A-40A00-R02
119A-NUT-40-R02	1.6	119A-40A00-R04
119A-NUT-56-R02	3.2	119A-56A00-R02
119A-NUT-56-R02	3.2	119A-56A00-R04
119A-NUT-80-R02	5.6	119A-80A00-R02
119A-NUT-92-R02	6.8	119A-92A00-R02

UNLESS OTHERWISE SPECIFIED TOLERANCE				 WWW.ATTEND.COM.TW
UNIT:	DECIMAL	LINEAR	ANGLES	
mm	X.	±0.50	±5°	
	X.X	±0.25	±3°	
	X.XX	±0.12	±1°	
DRAWN	Willis	2012/12/10	DRAWN NAME:	
CHECKED	Angel	2012/12/10	Mini PCI Express Stand Off	
APPROVED	Ken	2012/12/10	PRODUCT NO. see p/n table	
 SCALE 6.25	SHEET 1/1	SIZE A4	FILE NAME 119A-NUT-XX-R02_B_4	

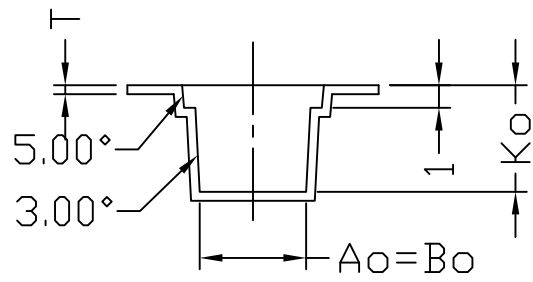
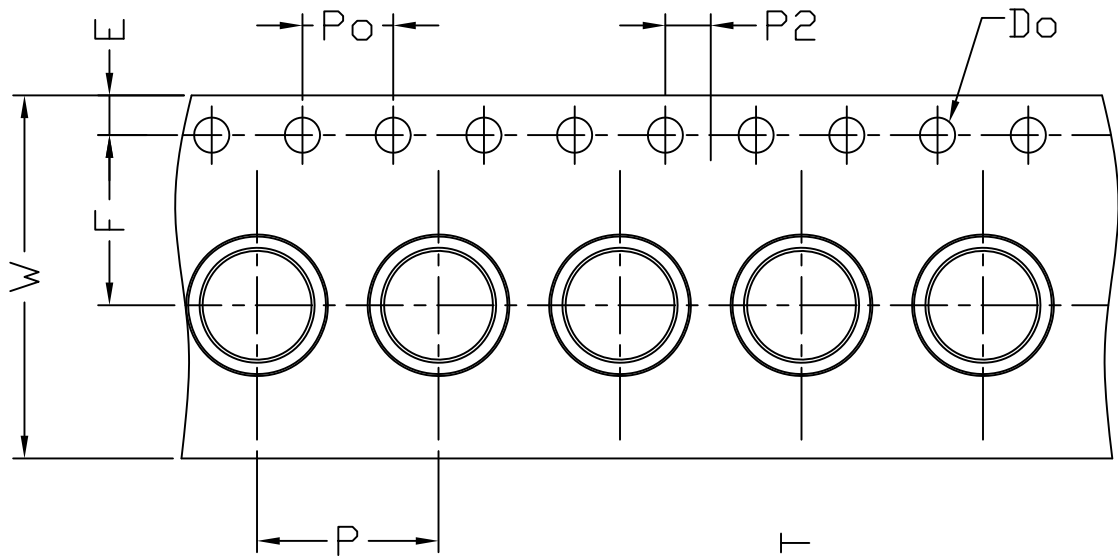

ITEM	DIM
W	16.00 ^{+0.30} _{-0.30}
E	1.75 ^{+0.10} _{-0.10}
F	7.50 ^{+0.10} _{-0.10}
P	8.00 ^{+0.10} _{-0.10}
P ₀	4.00 ^{+0.10} _{-0.10}
P ₂	2.00 ^{+0.10} _{-0.10}
D ₀	∅1.50 ^{+0.10} _{-0.00}
T	0.40 ^{+0.05} _{-0.05}
A ₀	∅4.70 ^{+0.10} _{-0.10}
B ₀	∅4.70 ^{+0.10} _{-0.10}
K ₀	4.70 ^{+0.10} _{-0.10}

1.MATERIAL: Black Anti-static Polystyrene
 2.Components loaded per 13" reel : 1700pcs

REV.	DESCRIPTION	DATE	REV.	DESCRIPTION	DATE	SIZE	REV.	FILE NAME
1			4			A4	1.0	119A-NUT-56-R02_D_3

UNLESS OTHERWISE SPECIFIED TOLERANCE			 www.attend.com.tw	
ANGLES	ANG.	±5°	DRAWN	Willis 2012/12/10
LINEAR	0.	±0.3	CHECKED	Angel 2012/12/10
	0.0	±0.25	APPROVED	Ken 2012/12/10
	0.00	±0.20	SCALE	AS SHOWN UNIT: mm
DRAWN NAME: Mini PCI Express Stand Off			PRODUCT NO.	119A-NUT-56-R02

REV.	DESCRIPTION	DRAWN	DATE
1	Initial Release	FROS	2020/04/16

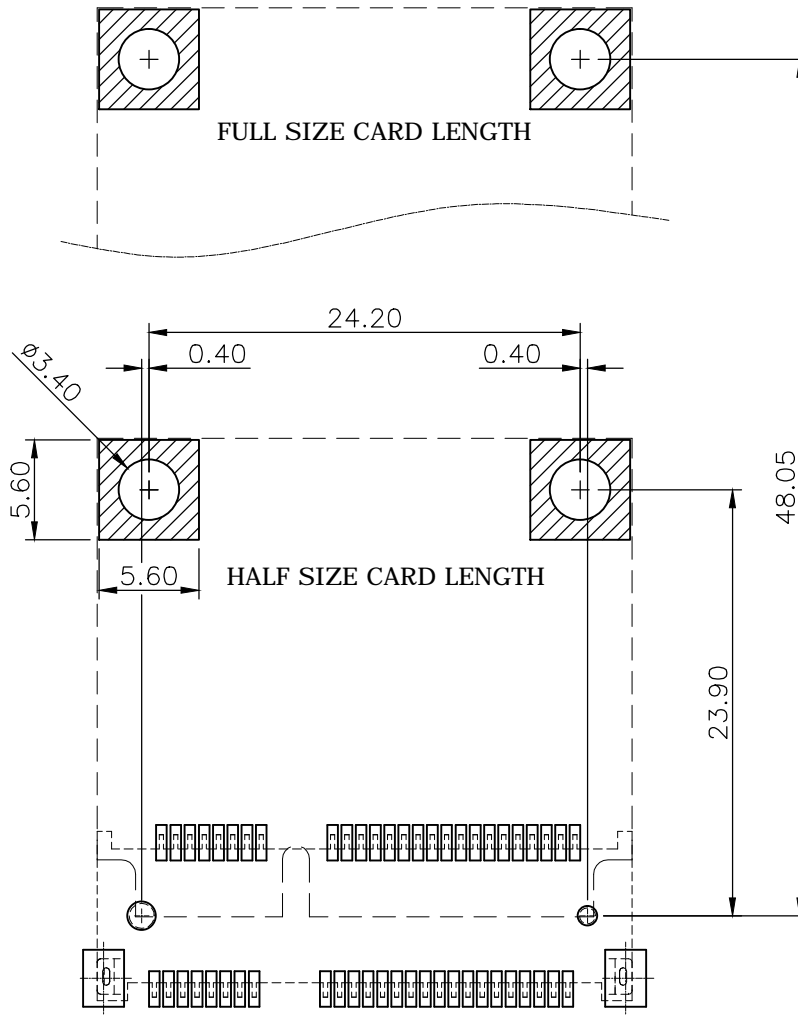

RECOMMEND LAYOUT (TOP VIEW)
GENERAL TOLERANCE: ±0.05

UNLESS OTHERWISE SPECIFIED TOLERANCE

UNIT:	DECIMAL	LINEAR	ANGLES
mm	X.	±0.50	±5°
	X.X	±0.25	±3°
	X.XX	±0.12	±1°



WWW.ATTEND.COM.TW

DRAWN	Fros	2020/04/16	DRAWN NAME: Mini PCI Express Stand Off Layout	
CHECKED	Tim	2020/04/16		
APPROVED	Ken	2020/04/16	PRODUCT NO.	
	SCALE 6.25	SHEET 1/1	SIZE A4	FILE NAME 119A-NUT-XX-R02_LAYOUT

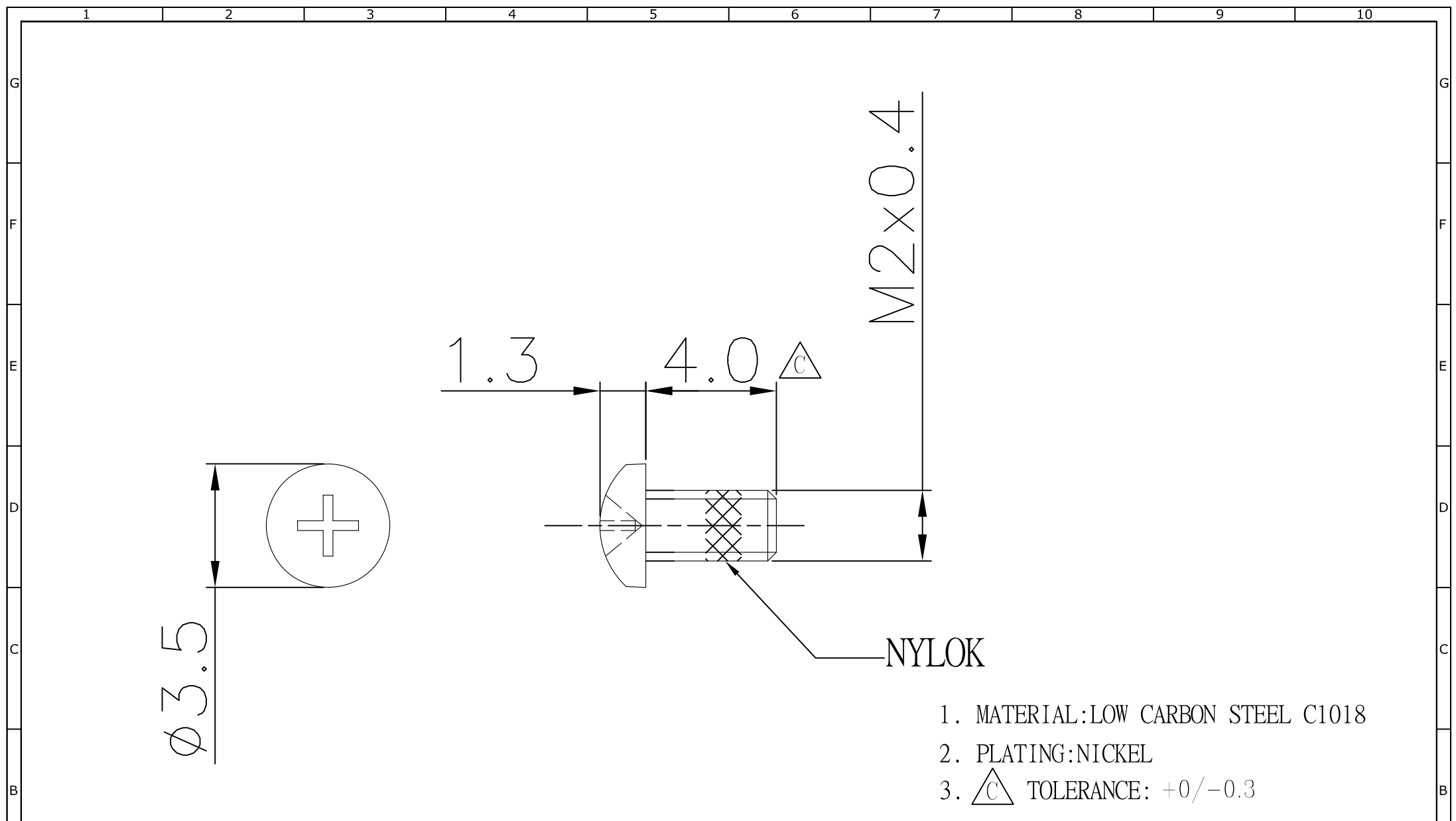

1. MATERIAL:LOW CARBON STEEL C1018
2. PLATING:NICKEL
3. $\triangle C$ TOLERANCE: +0/-0.3

REV.	DESCRIPTION	DATE	REV.	DESCRIPTION	DATE
1			4		
2			5		
3			6		

NOTES:			UNLESS OTHERWISE SPECIFIED TOLERANCE		
ANGLES	ANG.	$\pm 5^\circ$	LINEAR	0.0	± 0.3
		± 0.3		0.00	± 0.25
		± 0.20	SCALE	AS SHOWN	UNIT: mm
DRAWN	Willis	2013/01/25	CHECKED	Angel	2013/01/25
APPROVED	Ken	2013/01/25			

	
www.attend.com.tw	
DRAWN NAME: Mini PCI Express M2 Nylok Screw	
PRODUCT NO.	119A-Screw-R02
FILE NAME	119A-Screw-R02_B_2

REV.	DESCRIPTION	DATE	REV.	DESCRIPTION	DATE
1			4		
2			5		
3			6		