

KC3FB40H

Thyristors

400V, 3A

Feature

- Small SMD
- tq guaranteed
- High Sensitivity
- Pb free terminal
- RoHS:Yes

OUTLINE

Package (House Name): FB

Package (JEDEC Code): TO-252AA



Equivalent circuit

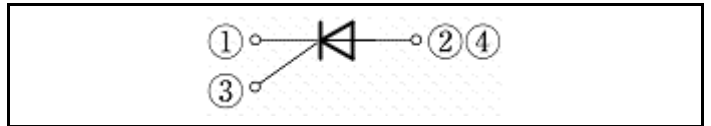

Absolute Maximum Ratings (unless otherwise specified : Tc=25°C)

Item	Symbol	Conditions	Ratings	Unit
Storage temperature	T _{stg}		-55 to 150	°C
Junction temperature	T _j		-40 to 125	°C
non-Repetitive peak off-state voltage	V _{DSM}	RGK=1KΩ	500	V
non-Repetitive peak reverse voltage	V _{RSM}	RGK=1KΩ	500	V
Repetitive peak off-state voltage	V _{DRM}	RGK=1KΩ	400	V
Repetitive peak reverse voltage	V _{RRM}	RGK=1KΩ	400	V
Average on-state Current	I _{T(AV)}	Tc=111°C, 50Hz sine wave, θ=180°	3	A
On-state current (r.m.s.)	I _{T(RMS)}	Tc=113°C, 50Hz sine wave, θ=180°	4	A
Peak surge on-state current	I _{TSM}	Tj=25°C, 50Hz sine wave, θ=180°, Non repetitive	40	A
Current squared time	I ² t	Tj=25°C, 1ms ≤ t ≤ 10ms, Non repetitive	8	A ² s
Peak gate dissipation	P _{FGM}	f ≥ 50Hz, Duty ≤ 10%	1	W
Average gate dissipation	P _{FG(AV)}		0.2	W
Peak gate forward current	I _{FGM}	f=50Hz, Duty ≤ 10%	0.5	A
Peak gate reverse voltage	V _{RGM}		6	V
Critical rate of rise of on-state current	di/dt		50	A/μs

* : See the original Specifications

Electrical Characteristics (unless otherwise specified : T_c=25°C)

Item	Symbol	Conditions	Ratings			Unit
			MIN	TYP	MAX	
Repetitive off-state current	I _{DRM}	VD=400V, RGK=1kΩ, Pulse measurement			50	μA
Repetitive reverse current	I _{RRM}	VR=400V, RGK=1kΩ, Pulse measurement			50	μA
On-state voltage	V _{TM}	ITM=4A, Pulse measurement			1.4	V
Gate trigger voltage	V _{GT}	VD=6V, RL=100Ω			0.8	V
Gate trigger current	I _{GT}	VD=6V, RL=100Ω			100	μA
Gate non-trigger voltage	V _{GD}	T _j =125°C, VD=1/2V _{DRM} , RGK=1kΩ	0.2			V
Holding Current	I _H	ITM=5A, RGK=1kΩ			5	mA
Critical rate of rise of off-state voltage	dVD/dt	T _j =125°C, VD=270V, RGK=1kΩ		16		V/μs
Turn-off time	t _q	T _j =125°C, ITM=2A, VR≥25V, diR/dt=15A/μs, VD=2/3V _{DRM} , RGK=1kΩ		18		μs
Thermal Resistance	R _{th(j-c)}	Junction to case			3	°C/W

※ :See the original Specifications

CHARACTERISTIC DIAGRAMS

On-state Voltage vs On-state Current

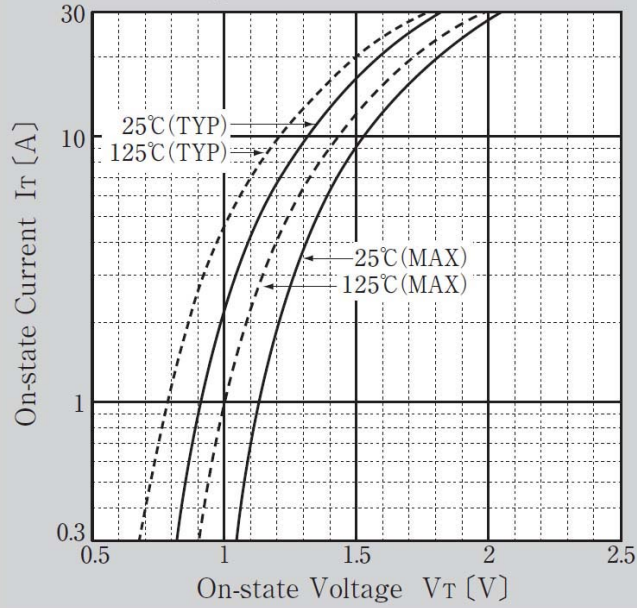

Surge On-state Current Capability

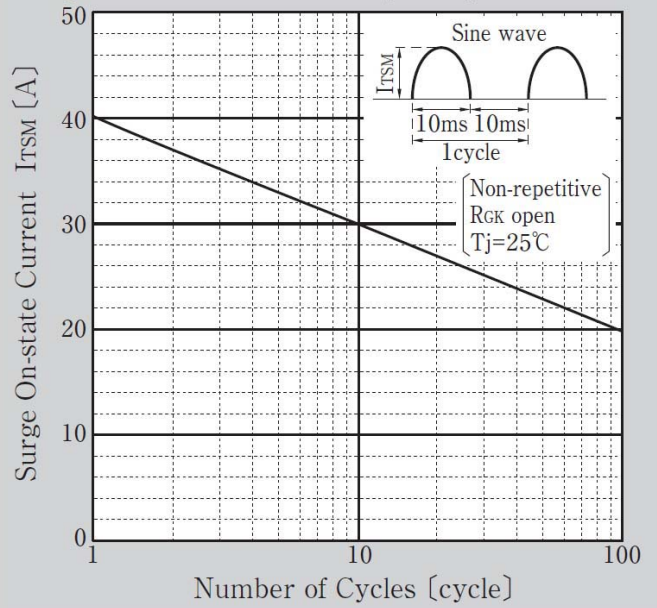

On-state Power Dissipation

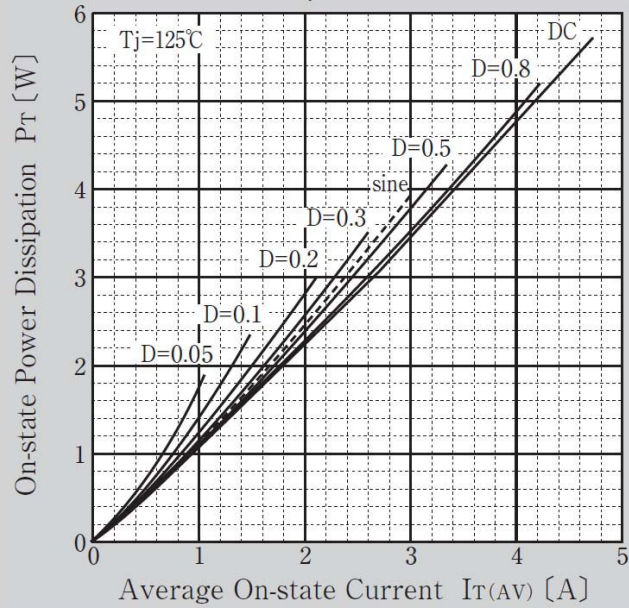

Derating Curve T_c-I_{T(AV)}

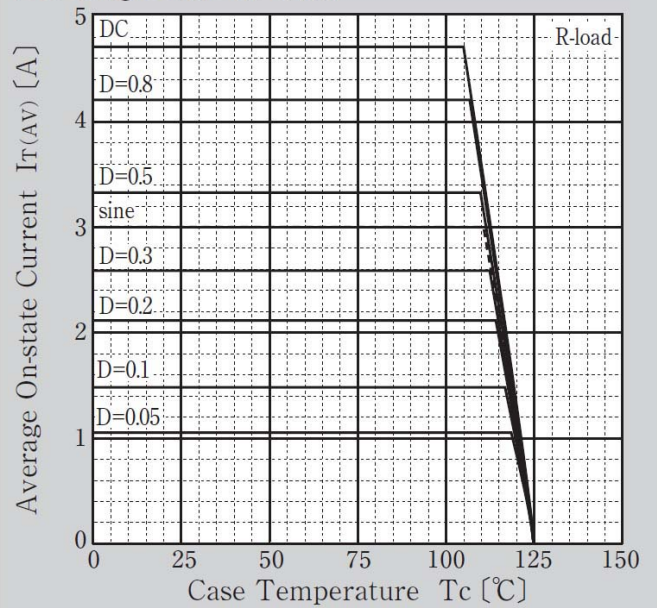

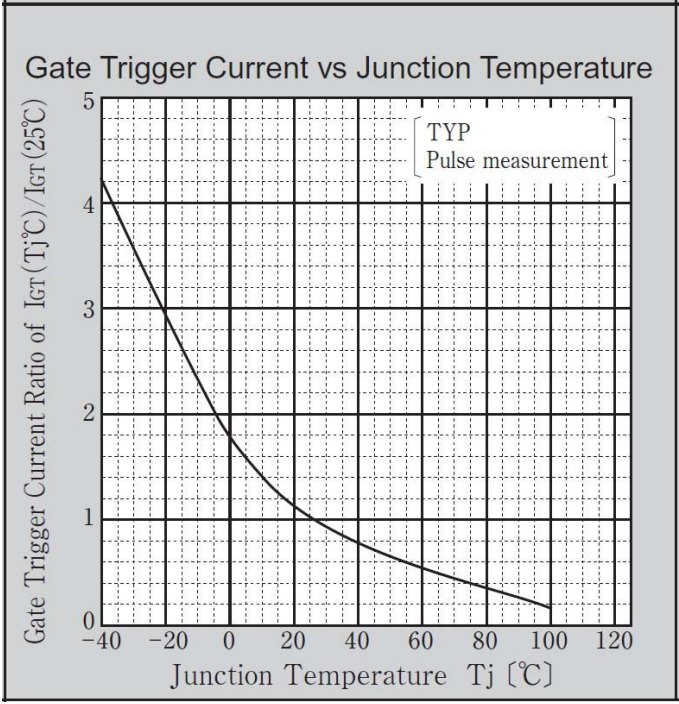
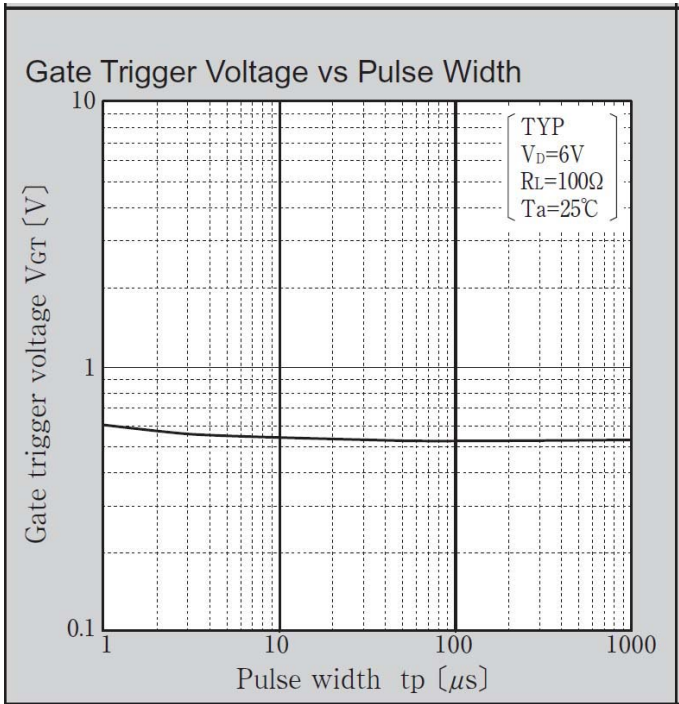
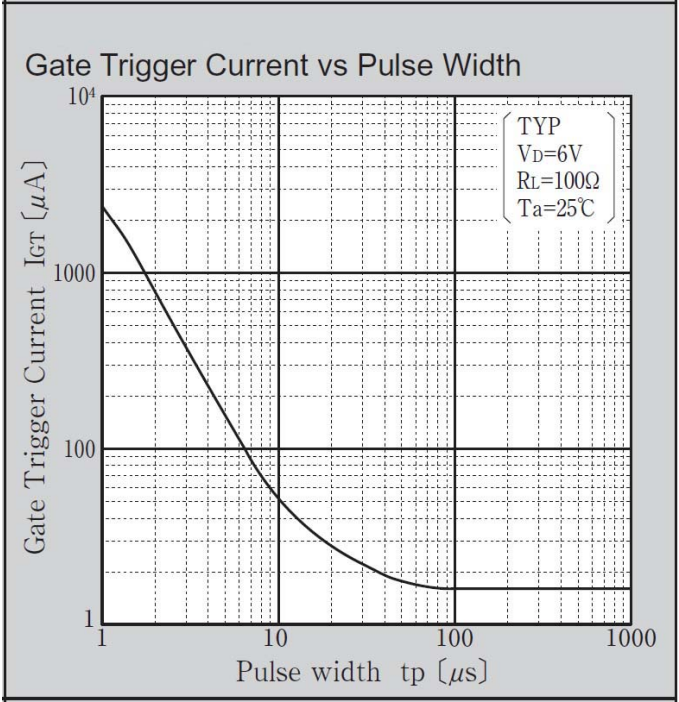
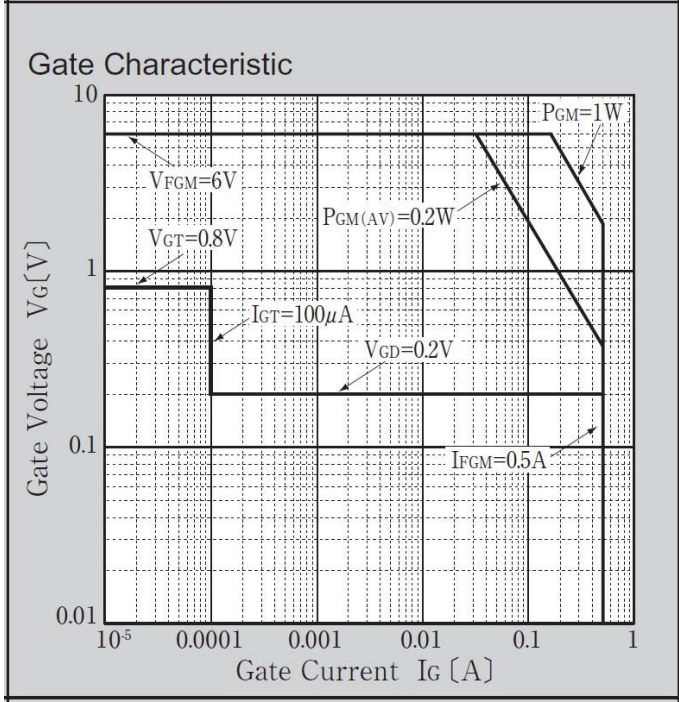

Holding Current vs Junction Temperature

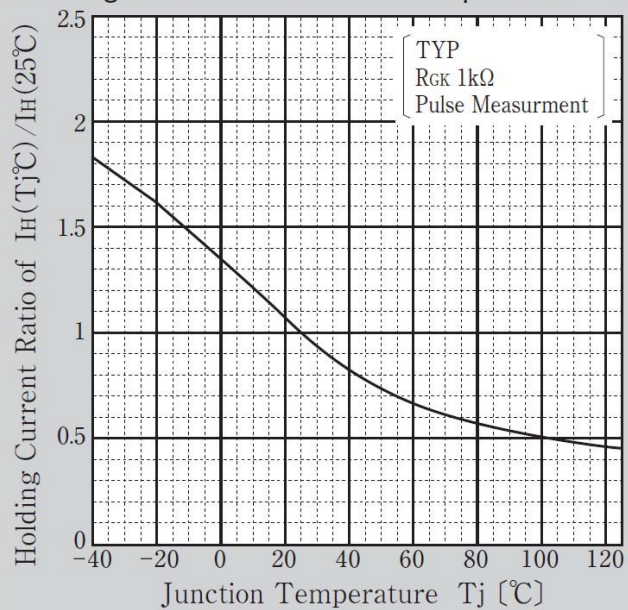

Gate Trigger Voltage vs Junction Temperature

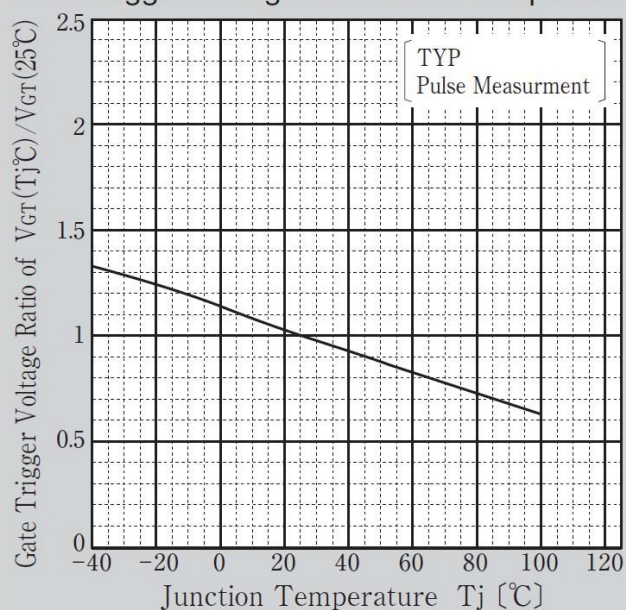

G2

JEDEC Code	TO-252AA
JEITA Code	-
House Name	FB

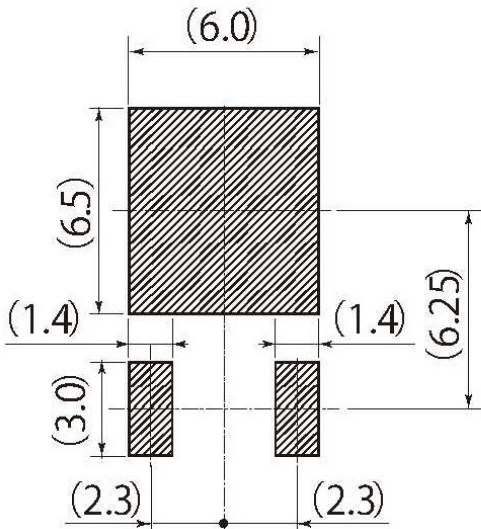
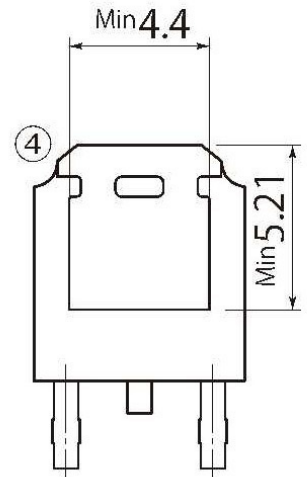
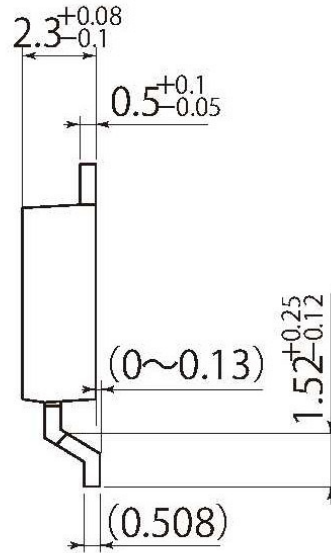
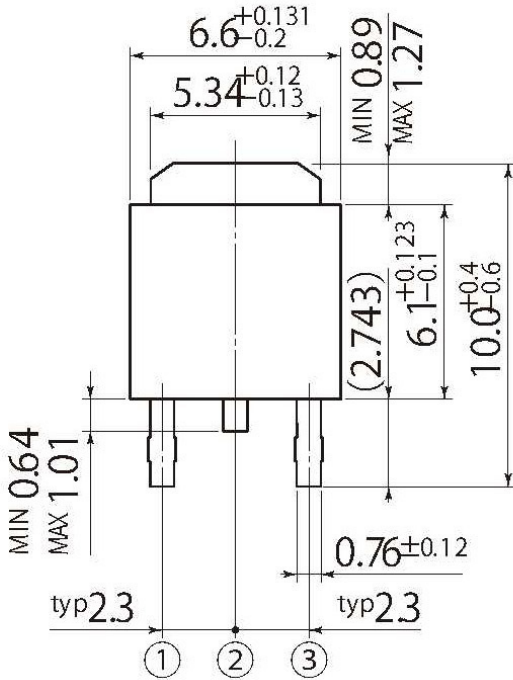

Referential Soldering Pad

• Optimize soldering pad to the board design and soldering condition.

Notes

1. If you wish to use any such product, please be sure to refer to the specifications issued by Shindengen.
2. All products described or contained herein are designed with a quality level intended for use in standard applications requiring an ordinary level of reliability. If these products are to be used in equipment or devices for special or specific applications requiring an extremely high grade of quality or reliability in which failures or malfunctions of products may directly affect human life or health, a local Shindengen office must be contacted in advance to confirm that the intended use of the product is appropriate. Shindengen products are grouped into the following three applications according to the quality grade.
 - 【Standard applications】
Computers, office automation and other office equipment, communication terminals, test and measurement equipment, audio/visual equipment, amusement equipment, consumer electronics, machine tools, personal electronic equipment, industrial equipment, etc.
 - 【Special applications】
Transportation equipment (vehicles, ships, etc.), trunk-line communication equipment, traffic signal control systems, anti-disaster/crime systems, safety equipment, medical equipment, etc.
 - 【Specific applications】
Nuclear reactor control systems, aircraft, aerospace equipment, submarine repeaters, life support equipment and systems, etc.
3. Although Shindengen continuously endeavors to enhance the quality and reliability of its products, customers are advised to consider and take safety measures in their design, such as redundancy, fire containment and anti-failure, so that personal injury, fires, or societal damages can be prevented.
4. Please note that all information described or contained herein is subject to change without notice due to product upgrades and other reasons. When buying Shindengen products, please contact the Company's offices or distributors to obtain the latest information.
5. Shindengen shall not bear any responsibility with regards to damages or infringement of any third-party patent rights and other intellectual property rights incurred due to the use of information on this website.
6. The information and materials on this website neither warrant the use of Shindengen's or any third party's patent rights and other intellectual property rights, nor grant license to such rights.
7. In the event that any product described or contained herein falls under the category of strategic products controlled under the Foreign Exchange and Foreign Trade Control Law of Japan, exporting of such products shall require an export license from the Japanese government in accordance with the above law.
8. No reprinting or reproduction of the materials on this website, either in whole or in part, is permitted without proper authorization from Shindengen.