

REVISION RECORD			
REV	ECN	DESCRIPTION	DRFT DATE

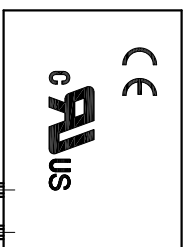
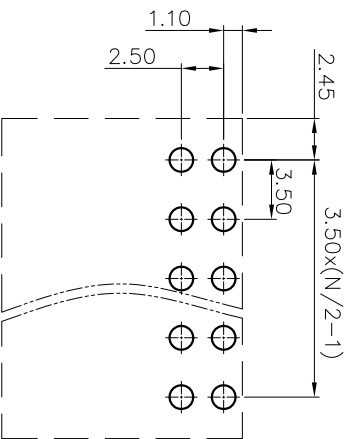
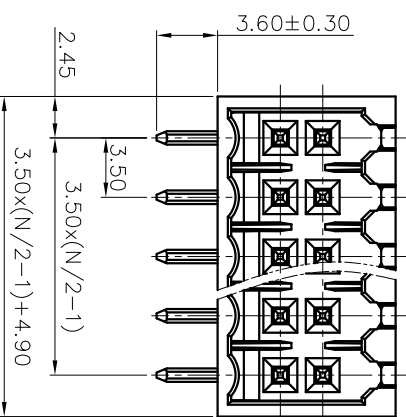
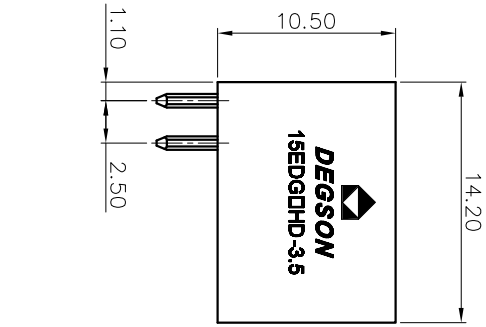
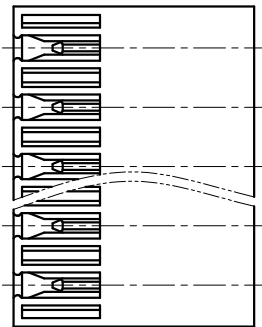

Pollution degree	2	2	3
Overvoltage category	II	III	III
Rate impulse voltage(kV)	2.5kV	2.5kV	2.5kV
Rate voltage(V)	250V	125V	80V
Rate current(A)	10A		

- NOTES1:
- UL Standard
 - Rated voltage/current : 150V / 10A
 - Withstanding voltage : AC1500V/1Min.
- IEC Standard

- NOTES2:
- Dimension shall be interpreted per ASME Y14.5-2009
 - Pitch : 3.50mm, Poles : N=04~48P
 - Operating temperature: -40°C~+105°C
 - Undimensioned tolerances:

Pitch range in mm	Over	Over	Over	Over	Over	Over	Over	Over	Over
6	10	10	30	60	100	150			
TO	TO	TO	TO	TO	TO	TO			
6	10	24	30	60	100	150			
±0.15	±0.20	±0.30	±0.30	±0.50	±0.70	±1.00	±1.30		

5.RoHS Compliance

15EDGRHD - 3.5 - XXP - 1Y - 00A (H)

(Series No.) (Pitch) (Poles) (Single Pitch) (Color) : 1.(Grey)
 2.(Blue)
 3.(Black)
 4.(Green)
 5.(Orange)
 6.(Red)
 7.(Transparent)
 8.(Yellow)
 9.(White)

00A - (Standard)
 (RoHS)

DETACHED LISTS			
PART NO.:	/	NAME:	DEGSON® NINGBO DEGSON ELECTRICAL CO., LTD 宁波高松电子有限公司
APPD:	/	CHKD:	/
DRFT:	/	TITLE:	CUSTOMER DRAWING
THIRD ANGLE PROJECTION		DRAWING NO.:	/
		DO NOT SCALE DRAWING	SCALE
			1:1

A B C D E F G H

8 7 6 5 4 3 2 1

A B C D E F G H