



Microwave Coaxial Connector

SWC/GSC/FSC/CCR/BFA Type

MICROWAVE COAXIAL CONNECTOR



- SWC Type
- GSC Type
- FSC Type
- CCR Type
- BFA Type

muRata

*Innovator
in Electronics*

Murata
Manufacturing Co., Ltd.

Cat.No.O30E-3

CONTENTS

- Ultra-Miniature SMT SWC Type 2-5
- Ultra-Miniature SMT GSC Type 6-9
- Miniature SMT FSC Type 10-14
- SMT CCR Type 15-18
- Low Profile BFA Type 19-22
- Miniaturized micro wave coaxial connector Cable list . . . 23-24



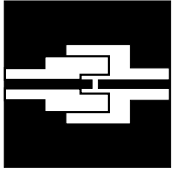

COAXIAL CONNECTOR



Ultra-Miniature SMT **SWC** Type

SMD type coaxial connector with switch. For high density mounting. Useful for automatic characteristic measurement of hand held phone.

FEATURES

1. The coaxial connector with switch is very useful for characteristic measurement of hand held phone and microwave circuit.
2. It is possible to switch the line connection and disconnection easily by special probe.
3. Small size, low profile. Size 3.4X3.3X1.9mm (LXWXH). Mounting dimension 11.2mm².
4. Excellent characteristic. Low IL (0.1dB max.). VSWR 1.2max at DC to 3GHz. Isolation 15 dB min.
5. Surface mountable and reflow solderable.
6. Tape package available.

APPLICATION

Cellular phone, PHS, Other wireless and measurement equipment.

PART NUMBER

● Receptacle (coaxial connector with switch)

Part Number	Packaging	Quantity
MM8329-2600	Bulk package	Free
MM8329-2600TB1	178mm Dia. Taping	1000pcs/reel
MM8329-2600TB2	330mm Dia. Taping	3000pcs/reel

● Probe for automatic measurement
MM126012

● L type probe with lock function
MXGM76RY1000

STRUCTURE (MM8329-2600)

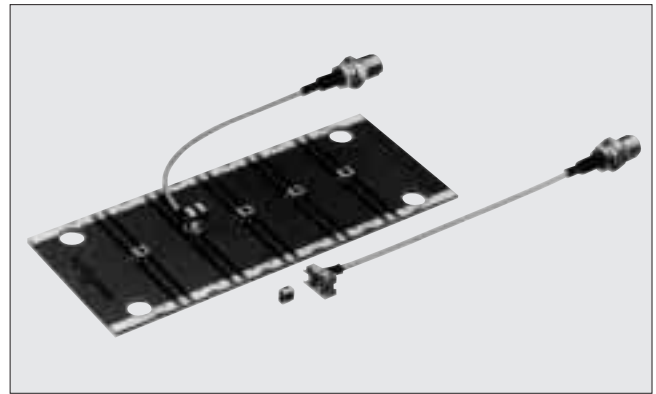
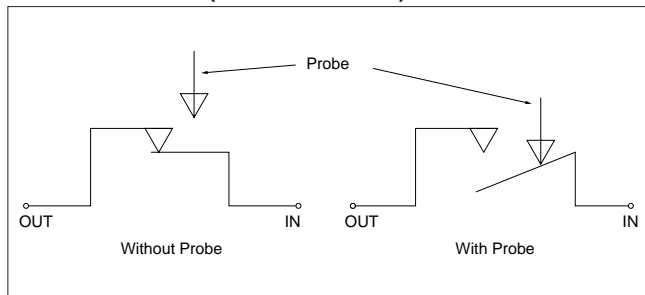

DIMENSIONS (MM8329-2600)

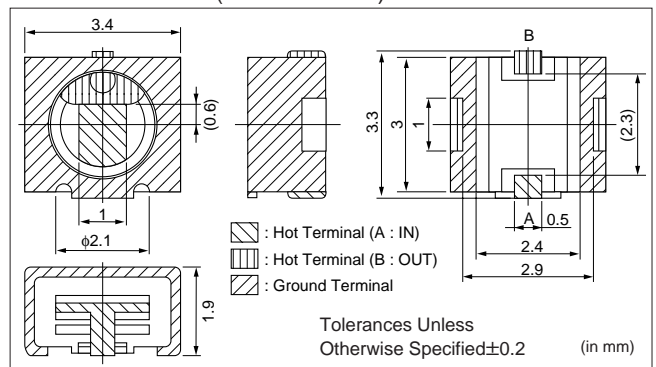

DIMENSIONS (MM126012)

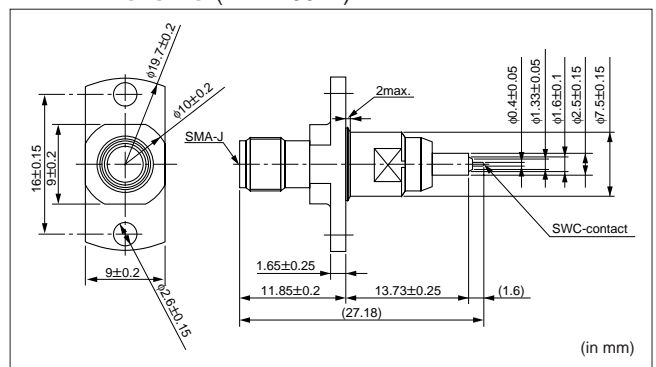

DIMENSIONS (MXGM76RY1000)

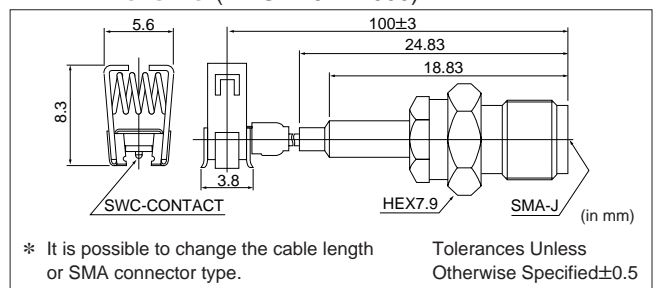

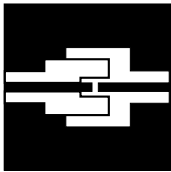

COAXIAL CONNECTOR



Ultra-Miniature SMT SWC Type

■ SPECIFICATION AND CHARACTERISTIC (COAXIAL CONNECTOR WITH SWITCH)

● Receptacle (MM8329-2600)

Item	Specification
Frequency Range	From DC to 3GHz
VSWR	1.2max.
Nominal Impedance	50Ω
Temperature Range	-40°C to +90°C
Voltage Rating	250Vrms
Contact Resistance	25mΩ max.
Withstanding Voltage	AC300±20Vrms
Insulation Resistance	500MΩ min.
IL at On switch	0.1dB max.
Isolation at OFF switch	15dB min.
Durability	50cycles

■ RATING AND CHARACTERISTICS

● Probe for automatic measurement (MM126012)

Item	Specification
Frequency Rating	DC to 3GHz
VSWR	1.5max.
Nominal Impedance	50Ω
Durability	100000

● L Type probe with lock function (MXGM76RY1000)

Item	Specification
Frequency Rating	DC to 3GHz
VSWR	1.3max.
Nominal Impedance	50Ω
Durability	1000

■ MATERIALS AND FINISH

Part Name	Material	Finish
Elastomer	Insulation rubber	None
Case	Engineering plastic	None
Ground terminal	Copper alloy	Silver plating
Hot terminal (A)	Copper alloy	Gold plating
Hot terminal (B)	Copper alloy	Gold plating

■ NOTICE

- Automatic measurement probe (MM126012)
MM126012 should be used on the condition in Fig.3 for good connection without any damages.
- L type probe with lock function (MXGM76RY1000)
 - See Fig.4. For connection, it should be confirmed if the direction of probe and receptacle are matched. Connect vertically with pinching the side of handle. After connection, the probe should be pushed from the top of handle, and be confirmed if it is locked. For disconnection, the probe should be disconnected vertically with pinching the side of handle. The probe must not be disconnected with pinching the cable not to have any damage.
 - The cable must not be twisted for protection of the center conductor assembled point.
 - For connector protection.
 - The stress for connector body.
See Fig.5. The stress over 2.94N (0.3kgf) must not be applied to the mated connector body from direction A or B.
 - The stress for cable assembled point.
See Fig.5. The stress over 2.94N (0.3kgf) must not be applied to the cable assembled point of mated connector from direction C.
 - The stress for cable.
See Fig.5. The stress over 14.7N (1.5kgf) must not be applied to the cable of connector to direction D.
- Pattern layout
Use the pattern in Fig.6 for the best characteristic.
- Soldering condition
 - Reflow soldering
Use the reflow profile as shown in Fig.1 and Fig.2.
 - Iron soldering
Use the following condition.
 - Preheating : 150°C, 60-120sec
 - Temperature of tip : 280°C
 - Time : less than 3sec.
 - Solder and flux
 - Use Rosin based flux, but not with strong acid flux (Chlorine content should be less than 0.20wt%).
 - Use the eutectic solder
 - The flux should not be left inside of receptacle because of the electrical performance degradation (contact resistance and etc.).
- Cleaning
Do not wash the this connector.
- Storage condition
Temperature : -10 to +40°C
Humidity : 30 to 80%RH

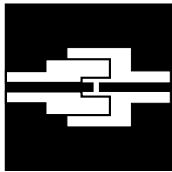

COAXIAL CONNECTOR



Ultra-Miniature SMT SWC Type

■ ALLOWABLE TEMPERATURE AND TIME OF REFLOW SOLDERING (Fig. 1)

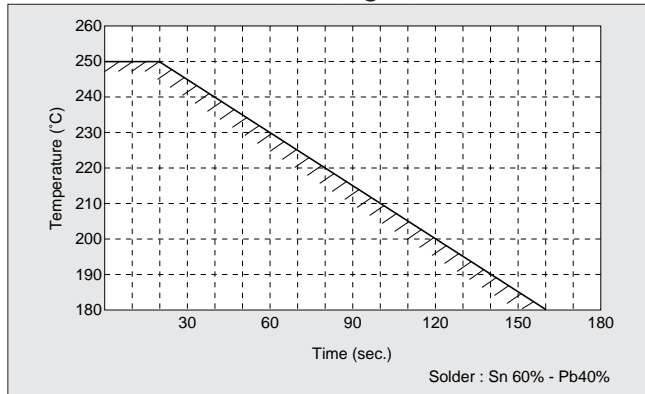

■ REFLOW SOLDERING STANDARD CONDITIONS (Fig. 2)

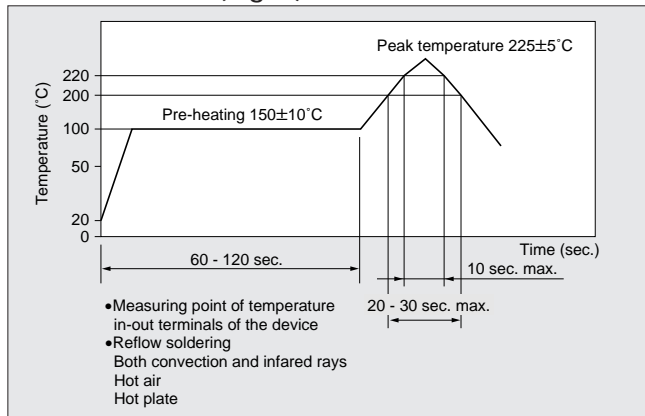

■ INSERTION THE AUTOMATIC MEASUREMENT PROBE (MM126012) in RECEPTACLE (MM8329-2600) (Fig. 3)

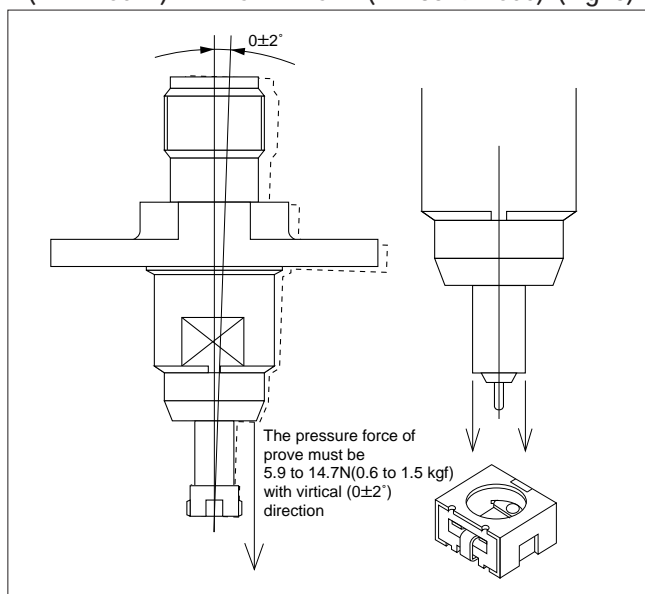

■ RECEPTACLE (MM8329-2600) AND L TYPE PROBE (MXGM76RY1000) CONNECTION AND DISCONNECTION (Fig. 4)

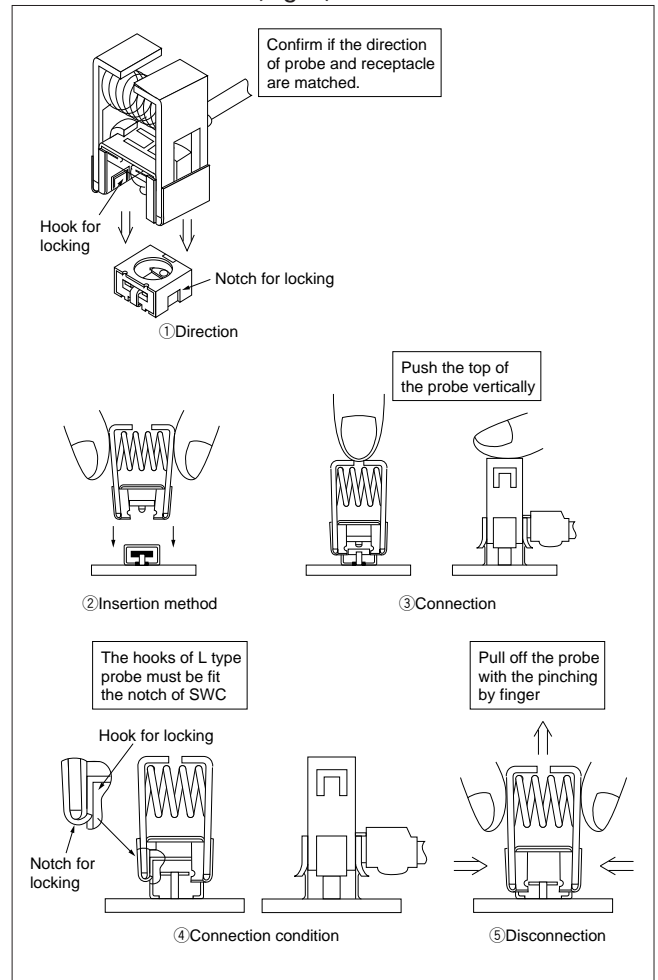

■ STRESS FOR MATED CONNECTOR (Fig. 5)

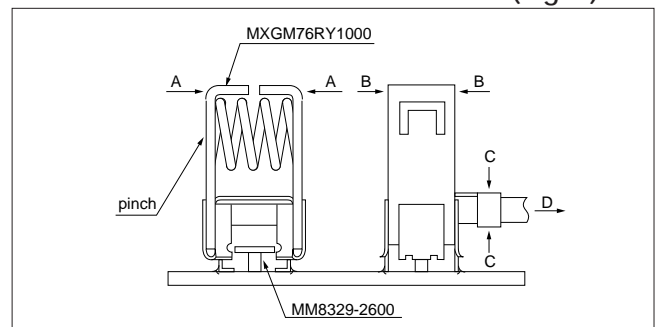

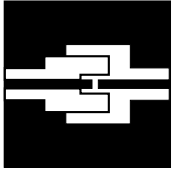

COAXIAL CONNECTOR



Ultra-Miniature SMT **SWC** Type

■LAND PATTERN (Fig. 6)

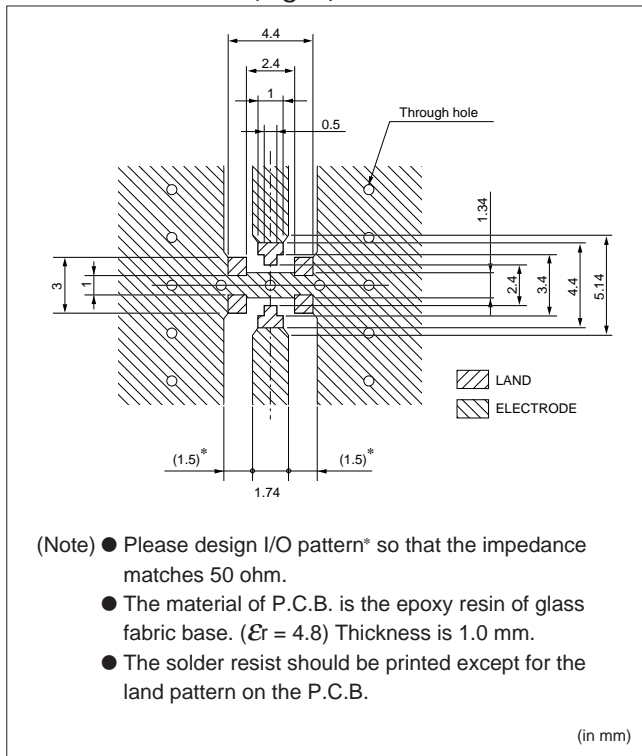

■DIMENSIONS OF PLASTIC TAPE (Fig. 7)

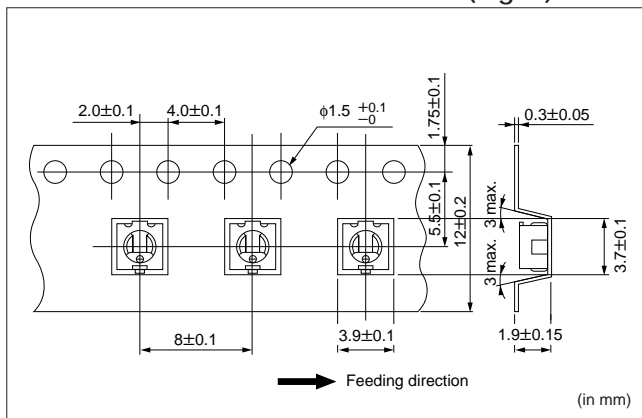

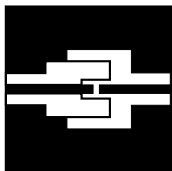

COAXIAL CONNECTOR



Ultra-Miniature SMT **GSC** Type

New coaxial connector GSC type. Microwave, Low profile 2mm height, SMD.

FEATURES

1. The mating height is only 2mm maximum by new mechanical design. Suitable for low profile design.
2. Receptacle size is 3.0X3.0mm. Suitable for high density design.
3. New mating mechanical design makes stable feeling connection.
4. Soft and ultra thin 0.8mm diameter flexible coaxial cables is available. Easy cable lay out will be realized. In addition to flexible cable, ultra thin 0.62mm diameter semi rigid cable is also available. Low insertion loss and low leakage will be realized.
5. High performance with wide frequency range (DC to 6GHz). VSWR at DC to 3GHz is 1.2 maximum. VSWR at 3GHz to 6GHz is 1.3 maximum.
6. Surface mountable and reflow solderable.
7. Tape package is available.

APPLICATIONS

Portable telephone, cordless telephone (analog and digital), GPS, and other microwave radio and measurement equipment.

PART NUMBER

- Straight receptacle for printed circuit board.

Part Number	Packaging	Quantity
MM9329-2700	Bulk package	Free
MM9329-2700TB1	178mm Dia. Taping	1000pcs/reel
MM9329-2700TB2	330mm Dia. Taping	5000pcs/reel

- Right angle cable assembly with flexible cable.

MXTK88□□□□□□ (Flexible Cable)
 MXTK92□□□□□□ (Flexible Cable)
 MXTK91□□□□□□ (Semirigid Cable)

- SMA-GSC adapters for receptacle.

MM121470 (Hand measurement)
 MM121471 (Automatic measurement)

- SMA-GSC adapter for cable assembly

MM121480

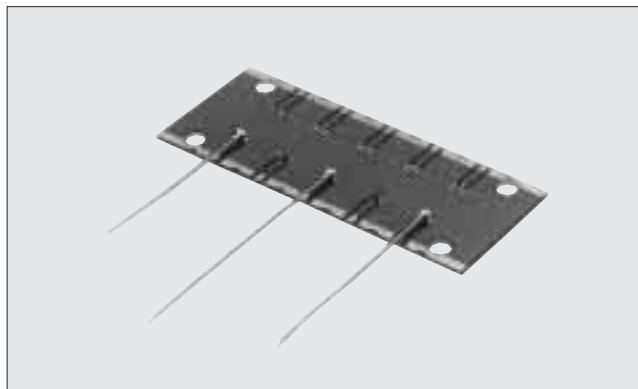

DIMENSIONS

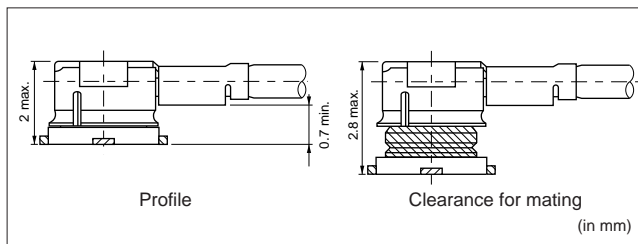

DIMENSIONS (MM9329-2700)

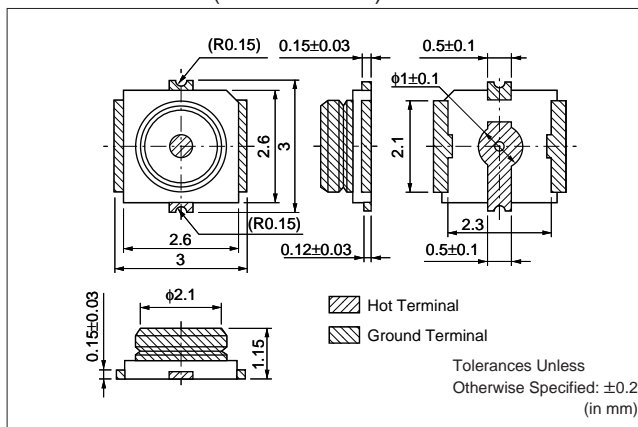

DIMENSIONS (MXTK92□□□□□□)

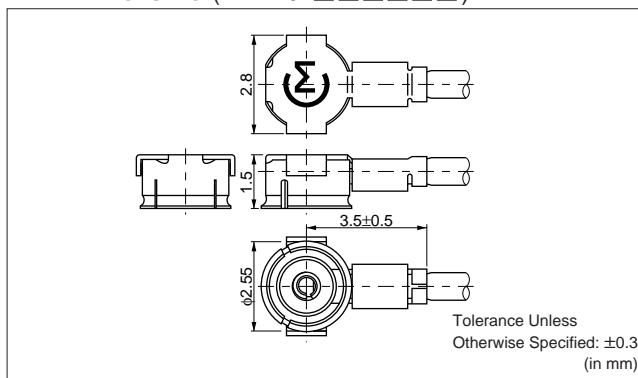

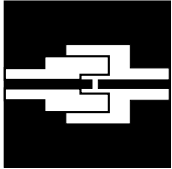

COAXIAL CONNECTOR



Ultra-Miniature SMT GSC Type

■ RATING AND CHARACTERISTICS

Item	Specification
Frequency Range	DC to 6GHz
VSWR	1.2 Max. (DC to 3GHz) 1.3 Max. (3GHz to 6GHz)
Nominal Impedance	50Ω
Temperature Range	-40°C to +90°C
Voltage Rating	250Vrms
Contact Resistance	15mΩ Max.
Withstanding Voltage	AC300Vrms
Insulation Resistance	500MΩ Min.
Durability	50 cycles

■ MATERIALS AND FINISH

● MM9329-2700

Part Name	Materials	Finish
Center Contact	Copper Alloy	Gold plated
Outer Contact	Copper Alloy	Silver plated
Insulator	Engineering plastic	None

● MXTK88

MXTK91

MXTK92

Part Name	Materials	Finish
Center Contact	Copper Alloy	Gold plated
Outer Contact	Copper Alloy	Silver plated
Insulator	Engineering plastic	None

■ PART NUMBERING FOR CABLE ASSEMBLY

(Please specify the part number when ordering.)



① Cable assembly

②④ Connector code

Code	Connector
TK	GSC type plug connector
XX	None

③ Cable code (See cable list on page 23 to 24 for detail.)

Code	Cable	Outer Diameter	Outer conductor construction	Insulation material	Minimum Bending radius
88	0.4D (*)	0.83mm	Single shield	PFA	3.3mm
92	0.4D (*)	0.8mm	Single shield	PFA	3.3mm
91	0.52D (*)	0.62mm	Semirigid cable	PTFE	3.2mm

(*) Based on Japanese Industrial Standard (JIS).

⑤⑥ Full length of cable assembly

Length (mm) = ⑤ × 10^⑥

Ex. : 500mm = 500 × 10⁰ → 5000

1000mm = 100 × 10¹ → 1001

■ SMA-GSC ADAPTERS

● SMA-GSC adapters for receptacle

MM121470 (Hand measurement)

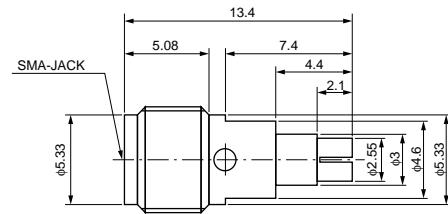

(in mm)

MM121471 (Automatic measurement)

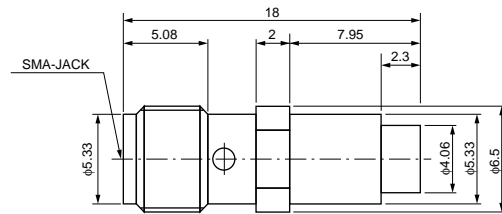

(in mm)

● SMA-GSC adapter for cable assembly

MM121480

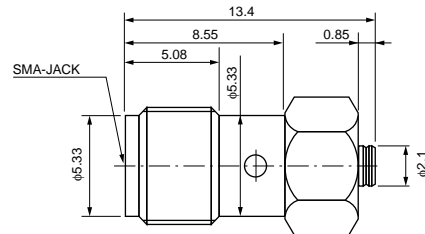

(in mm)

■ CABLE LENGTH TOLERANCE

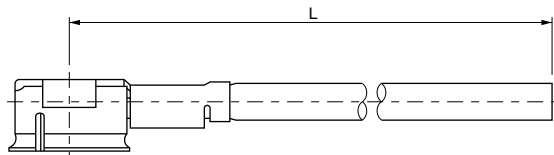

Cable Length L (mm) (*)		Dimensional tolerance (mm)
Over	Till	
40	100	±3
100	500	±4
500	1000	±10
1000	-	+2% of L -0% of L

* L must be 20mm Min.

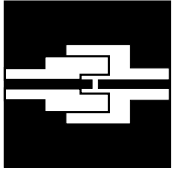

COAXIAL CONNECTOR



Ultra-Miniature SMT GSC Type

NOTICE

Disaccord with following notes could give mechanical damage and/or poor electrical performance.

1. Mechanical Stress :

Stress to the connector should be limited as shown Fig.1.

2. PCB mount pattern dimension :

Dimensions shown in Fig. 2 should be used for the PCB design.

3. Disengagement and engagement.

Use tool P/N M22001 (Fig.3). The connector to be disengaged and engaged should be pulled out or insert to the vertical direction using the tool. Do not try to pull out by the cable, because there is the possibility a wire breaks.

4. Cable and connector handling :

Do not give a twisted torque to the cable and connector.

5. Reflow soldering condition :

Reflow soldering should be carried out according to condition as shown in Fig.4.

And the eutectic solder should be used.

6. When MM9329-2700 was soldered on P.C.B.,

- Use the metal mask pattern as illustrated in Fig.2 (Thickness is 0.15mm) in order to print the proper quantity.
- Use Rosin based flux, but not with strong acid flux (Chlorine content should be less than 0.20wt%).
- Flux should be cleaned thoroughly.

7. Washing :

In case of cleaning the receptacle, please dry out the receptacle immediately after cleaning.

Do not wash cable assembly.

8. Storage of temperature and humidity.

Temperature : -10 to +40°C

Humidity : 30-80%RH

STRESS TO THE CONNECTOR (Fig.1)

1. Stress to the housing
Stress A and B : 4.9N (0.5kgf) max.
2. Stress to the outer sleeve.
Stress C : 2.94N (0.3kgf) max.
Stress D : 1.96N (0.2kgf) max.
3. Cable pull strength.
Stress E : 4.9N (0.5kgf) max. (for 88, 92, 91 cable)

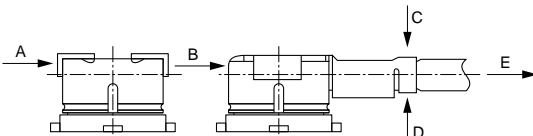

PATTERN DIMENSION, METAL MUSK PATTERN (Fig. 2)

(i) Pattern Dimension

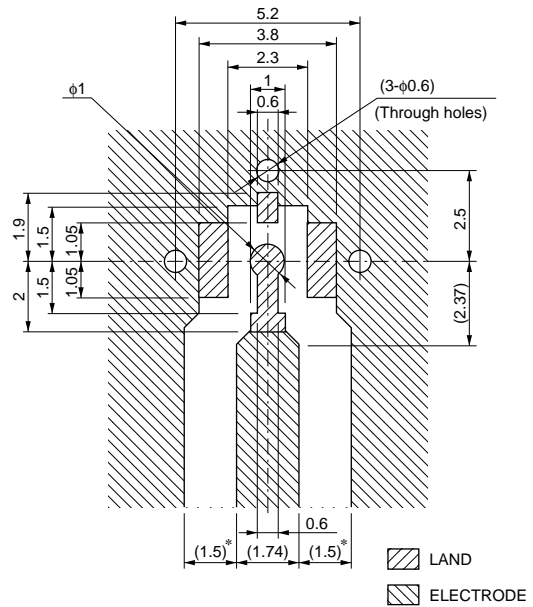

(in mm)

- (Note)
- Please design I/O pattern so that the impedance matches 50 ohm including the land pattern.
 - The material of P.C.B. is the epoxy resin of glass fabric base. ($\epsilon_r = 4.8$) Thickness is 1.0 mm.
 - The solder resist should be printed except for the land pattern on the P.C.B.

(ii) Metal Musk Pattern

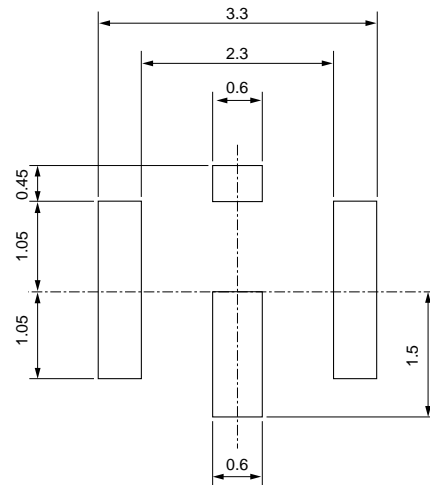

(in mm)

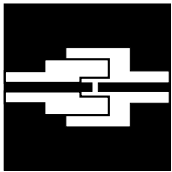

COAXIAL CONNECTOR



Ultra-Miniature SMT GSC Type

TOOL (Fig. 3)

M22001

(in mm)

How to use tool

STANDARD REFLOW SOLDERING CONDITIONS (Fig. 4)

Allowable Temperature and Time of Reflow Soldering

Solder : Sn 60%-Pb 40%

Reflow Soldering Standard Conditions

- Measuring point of temperature in-out terminals of the device
- Reflow Soldering
- Both convection and infrared rays
- Hot air
- Hot plate

DIMENSIONS OF PLASTIC TAPE (Fig. 5)

Feeding direction

Tolerances Unless
Otherwise Specified ±0.1
(in mm)

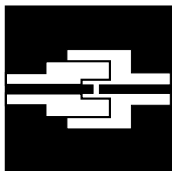

COAXIAL CONNECTOR



Miniature SMT FSC Type

Miniature, Low profile, 3mm height, SMD. Right angle type receptacle available.

FEATURES

1. High engagement with new structure (50% up compared with ESC type).
2. Ultra-miniature (LXWXH : 3.4X3.4X1.5mm) for High density mounting (11.6mm²).
3. Ultra-low profile (3.0mm Max.).
4. High performance. (VSWR 1.2max. at 2GHz).
5. Matched with ultra-thin FEP coaxial cables (0.8mm dia).
6. Mountable by automatic placer.
7. Taping package applicable.
8. SMD and reflow soldering applicable.

APPLICATIONS

Portable telephone, mobile telephone, cordless telephones, GPS, and other microwave radio and measurement equipment.

PART NUMBER

● Straight receptacle for printed circuit board.

Part Number	Packaging	Quantity
MM7329-2700	Bulk package	Free
MM7329-2700TB1	178mm Dia. Taping	1000pcs/reel
MM7329-2700TB2	330mm Dia. Taping	4000pcs/reel

● Right angle receptacle for printed circuit board.

Part Number	Packaging	Quantity
MM7329-2702	Bulk package	Free
MM7329-2702TB1	178mm Dia. Taping	500pcs/reel
MM7329-2702TB2	330mm Dia. Taping	2000pcs/reel

● Right angle cable assembly with flexible cable.

MXFK81□□□□□□
MXFG76□□□□□□

● SMA-FSC adapter for receptacle.

MM121454

● SMA-FSC adapter for cable assembly.

MM121460

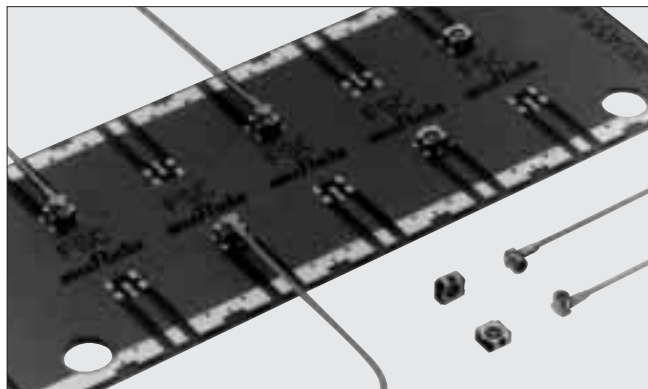

DIMENSIONS

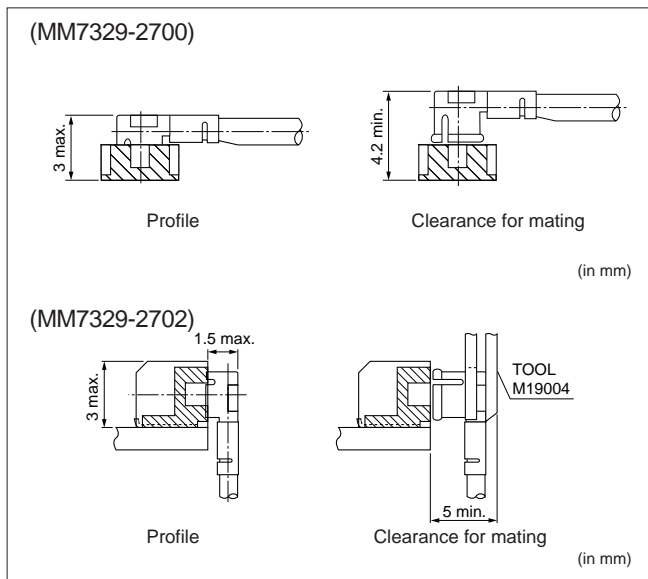

RATING AND CHARACTERISTICS

Item	Specification
Frequency Range	DC to 3GHz
VSWR	1.2Max. (DC to 2GHz) 1.3Max. (2GHz to 3GHz)
Nominal Impedance	50Ω
Temperature Range	-40°C to +90°C
Voltage Rating	250Vrms
Contact Resistance	15mΩ Max.
Withstanding Voltage	AC300Vrms
Insulation Resistance	500MΩ Min.
Durability	50cycles

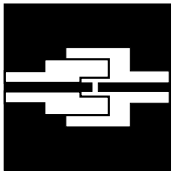

COAXIAL CONNECTOR



Miniature SMT FSC Type

■ DIMENSIONS (MM7329-2700)

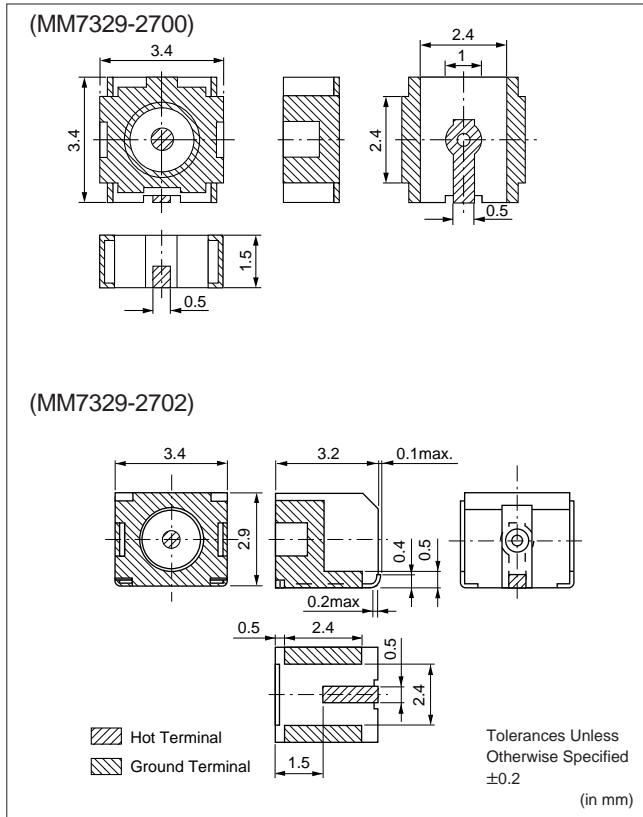

■ DIMENSIONS (MXFK81□□□□□□)

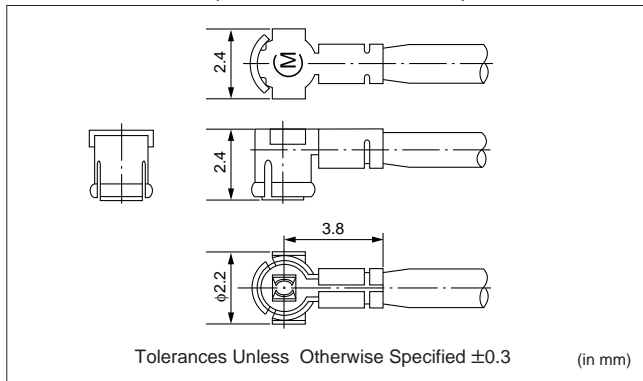

■ MATERIALS AND FINISH

● MM7329-2700/MM7329-2702

Part Name	Materials	Finish
Center Contact	Copper Alloy	Gold plated
Outer Contact	Copper Alloy	Gold plated
Insulator	Engineering plastic	None

● MXFK81□□□□□□

MXFG76□□□□□□

Part Name	Materials	Finish
Center Contact	Copper Alloy	Gold plated
Outer Contact	Copper Alloy	Gold plated
Insulator	Engineering plastic	None

■ PART NUMBERING FOR CABLE ASSEMBLY

(Please specify the part number when ordering.)



- ① Cable assembly
- ②④ Connector code

Code	Connector
FK	FSC type Plug connector (for 81 cable)
FG	FSC type Plug connector (for 76 cable)
XX	None

③ Cable code (See cable list on page 23 to 24 for detail.)

Code	Cable	Outer Diameter	Outer conductor construction	Insulation material	Minimum Bending radius
81	0.4D (*)	0.8mm	Single shield	FEP	4.8mm
76	0.8D (*)	1.25mm	Single shield	FEP	6mm

(*) Based on Japanese Industrial Standard (JIS).

⑤⑥ Full length of cable assembly

$$\text{Length (mm)} = \text{⑤} \times 10^{\text{⑥}}$$

Ex. : 500mm = 500 × 10⁰ → 5000

1000mm = 100 × 10¹ → 1001

■ CABLE LENGTH TOLERANCE

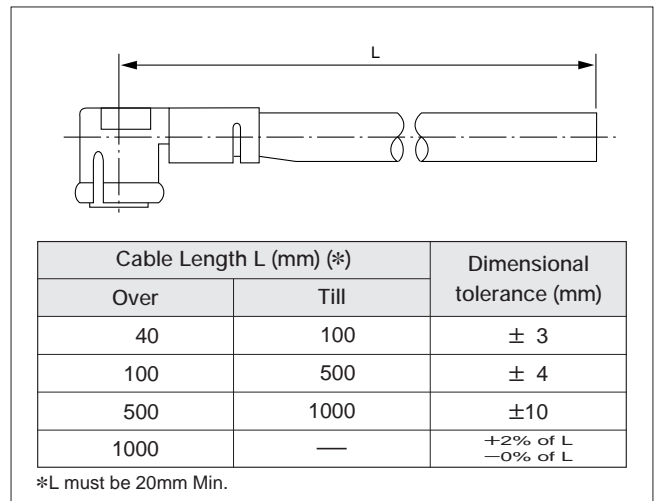

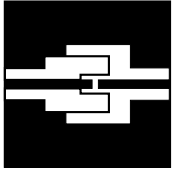

COAXIAL CONNECTOR



Miniature SMT FSC Type

■ SMA-FSC ADAPTERS

MM121454 (For FSC type receptacle)

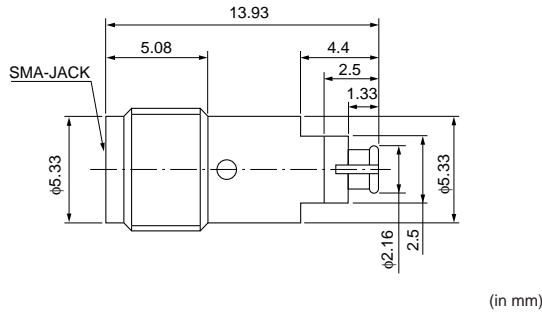

MM121460 (For FSC type cable assembly)

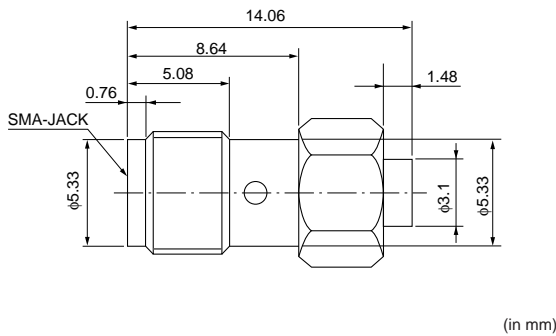

■ NOTICE

Disaccord with following notes could give mechanical damage and/or poor electrical performance.

1. Mechanical Stress :
Stress to the connector should be limited as shown Fig.1.
2. PCB mount pattern dimension :
Dimensions shown in Fig. 2 should be used for the PCB design.
3. Disengagement and engagement.
Use tool P/N M19000 or M19004 (Fig.3). The connector to be disengaged and engaged should be pulled out or insert to the vertical direction using the tool. Do not try to pull out by the cable, because there is the possibility a wire breaks.
4. Cable and connector handling :
Do not give a twisted torque to the cable and connector.
5. Reflow soldering condition :
Reflow soldering should be carried out according to condition as shown in Fig.4.
And the eutectic solder should be used.
6. When MM7329-2700/MM7329-2702 was soldered on P.C.B.,
 - Use Rosin based flux, but not with strong acid flux (Chlorine content should be less than 0.20wt%).
 - Flux should be cleaned thoroughly.
7. Washing :
In case of cleaning the receptacle, please dry out the receptacle immediately after cleaning.
Do not wash cable assembly.
8. Storage of temperature and humidity.
 Temperature: -10 to +40°C
 Humidity : 30-80%RH

■ STRESS TO THE CONNECTOR (Fig.1)

1. Stress to the housing
Stress A and B : 4.9N (0.5kgf) max.
2. Stress to the outer sleeve.
Stress C : 2.94N (0.3kgf) max.
Stress D : 1.96N (0.2kgf) max.
3. Cable pull strength.
Stress E : 4.9N (0.5kgf) max. (for 81 cable)
: 7.84N (0.8kgf) max. (for 76 cable)

(MM7329-2700)

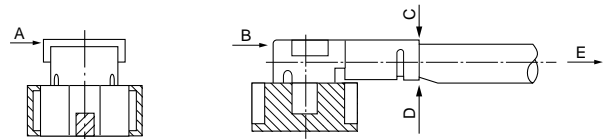

(MM7329-2702)

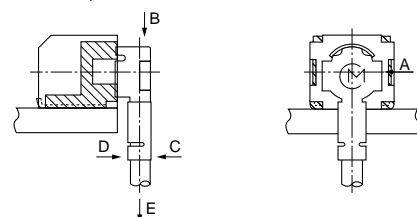

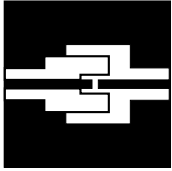

COAXIAL CONNECTOR



Miniature SMT FSC Type

■ PATTERN DIMENSION (Fig. 2)

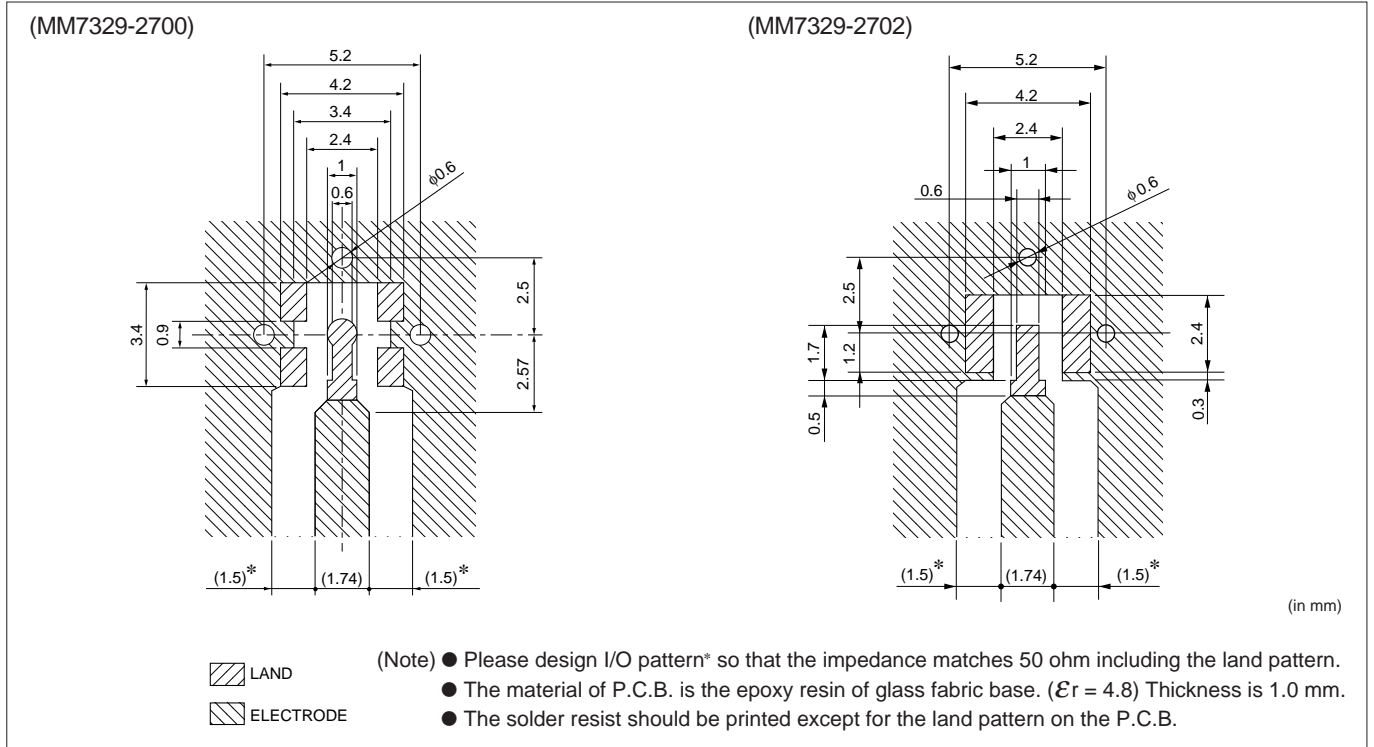

■ TOOL (Fig. 3)

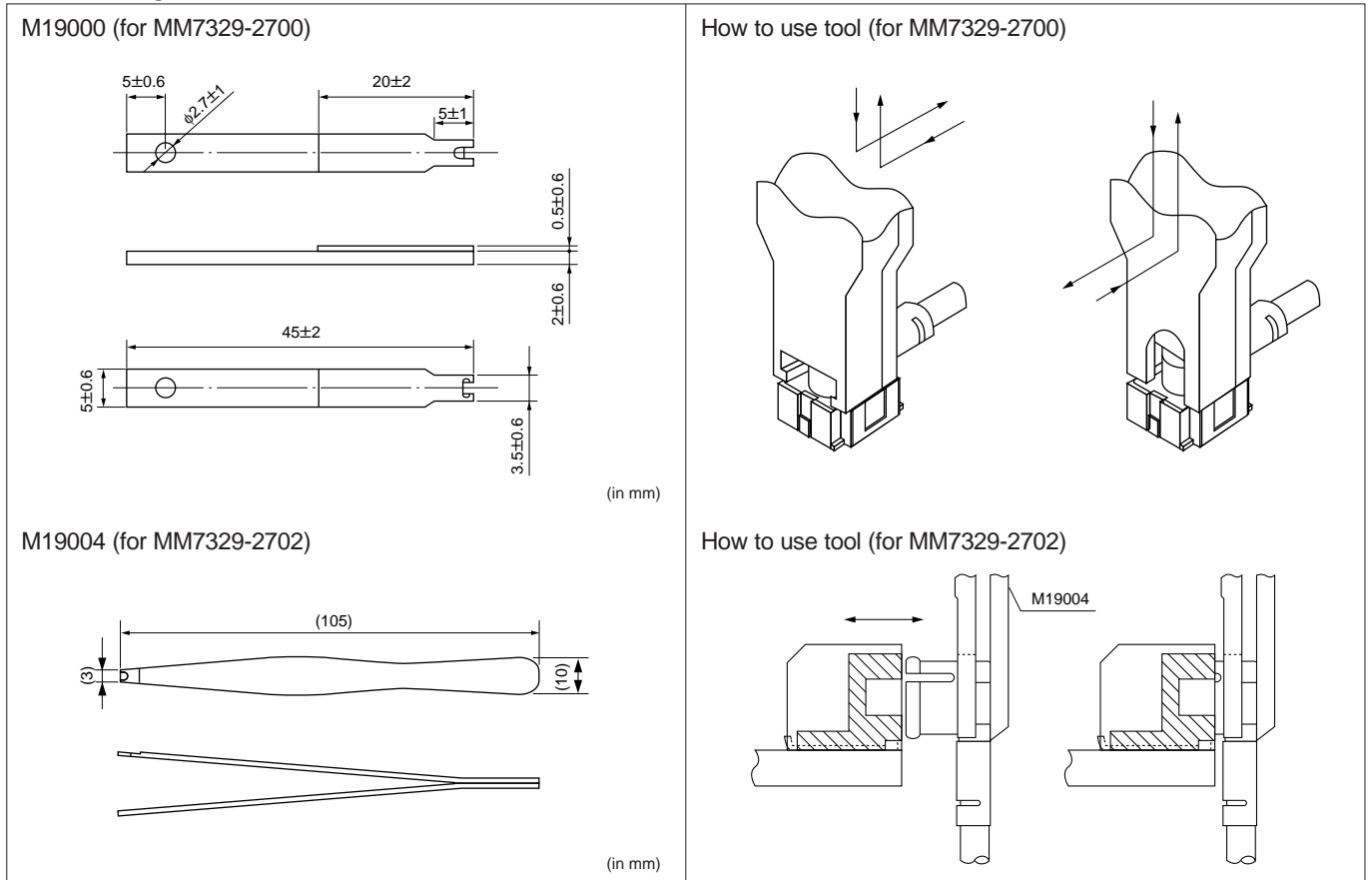

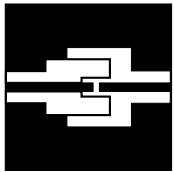

COAXIAL CONNECTOR



Miniature SMT FSC Type

STANDARD REFLOW SOLDERING CONDITIONS (Fig. 4)

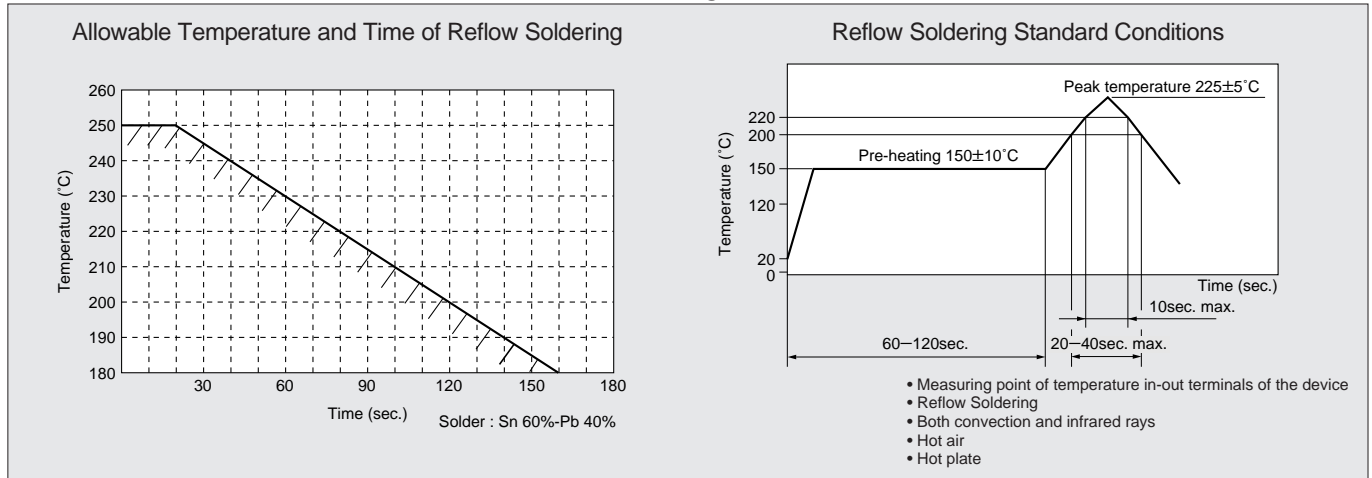

DIMENSIONS OF PLASTIC TAPE (Fig. 5)

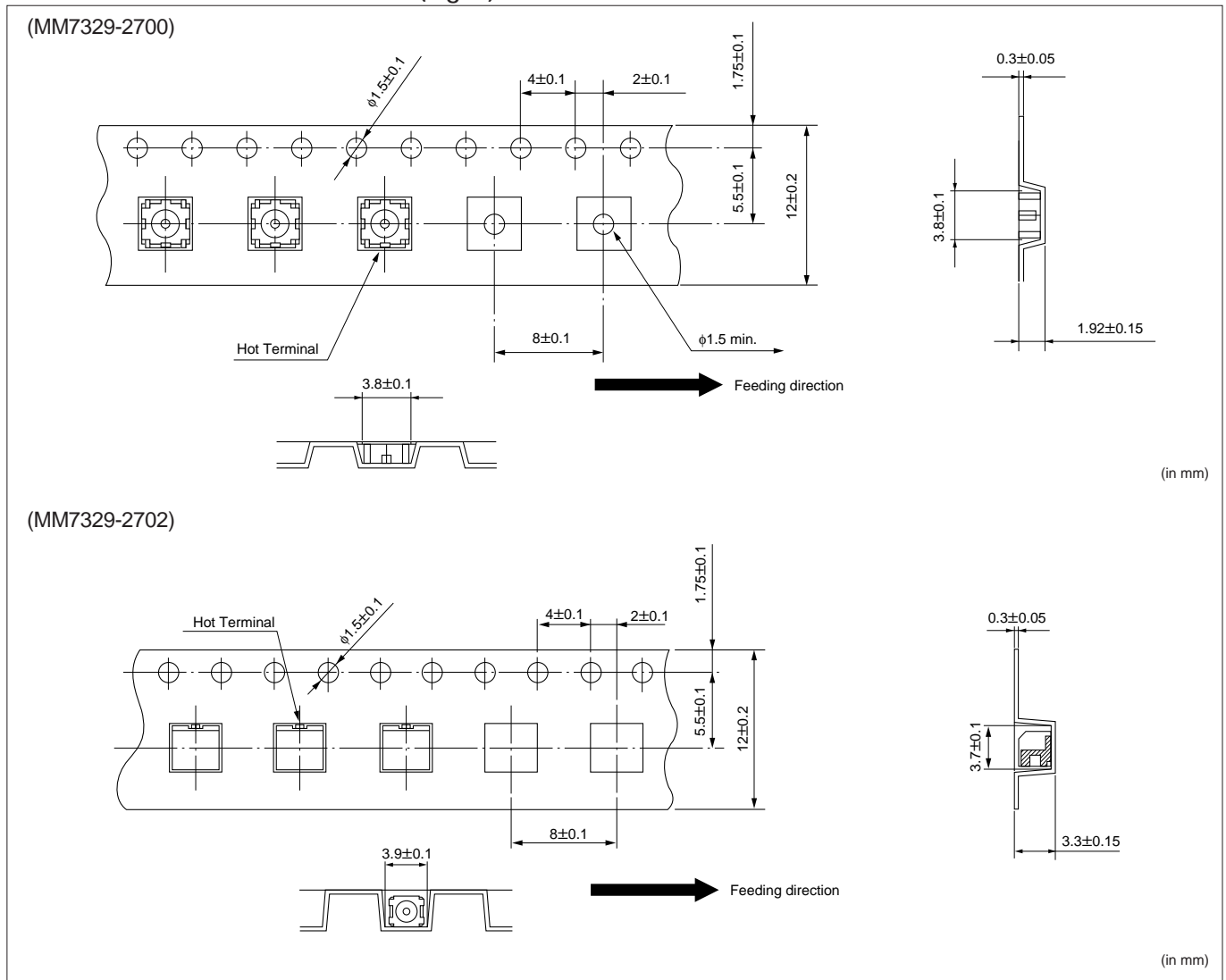

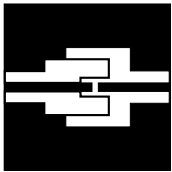

COAXIAL CONNECTOR



SMT CCR Type

4.2mm height, SMD. Strong Engage Force.

FEATURES

1. Ultra-miniature and low profile. (4.2mm Max.)
2. SMD and reflow soldering applicable.
3. Taping package applicable.
4. Mountable by automatic placer.
5. High performance. (VSWR 1.2 Max. at 2GHz)
6. Available for ultra-thin coaxial cables.

APPLICATIONS

Portable telephones, mobile telephones, cordless telephones, GPS, and other microwave radio and measurement equipment.

PART NUMBER

● Straight receptacle for printed circuit board.

Part Number	Packaging	Quantity
MM4329-2700	Bulk package	Free
MM4329-2700TB1	178mm Dia. Taping	500pcs/reel
MM4329-2700TB2	330mm Dia. Taping	3000pcs/reel

● Right angle cable assembly with flexible cable.

MXSG63□□□□□□

● SMA-CCR adapter for receptacle

MM121390

● SMA-CCR adapter for cable assembly

MM121400

RATING AND CHARACTERISTICS

Item	Specification
Frequency Range	DC to 2GHz
VSWR	1.2Max.
Nominal Impedance	50Ω
Temperature Range	-40°C to +90°C
Voltage Rating	250Vrms
Insulation Resistance	500MΩ Min.
Contact Resistance	15mΩ Max.
Withstanding Voltage	AC300Vrms
Durability	50cycles

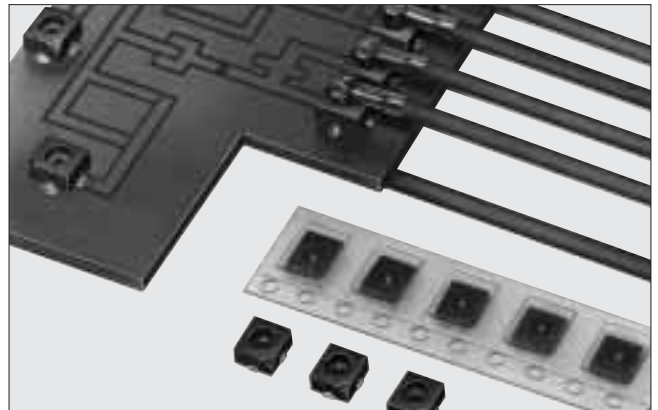

DIMENSIONS

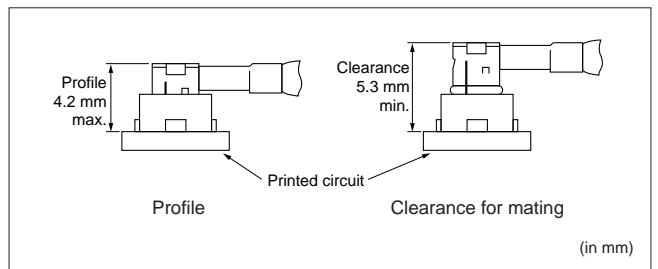

DIMENSIONS (MM4329-2700)

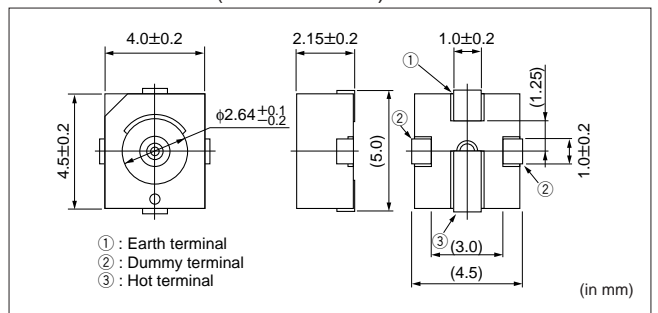

DIMENSIONS (MXSG63□□□□□□)

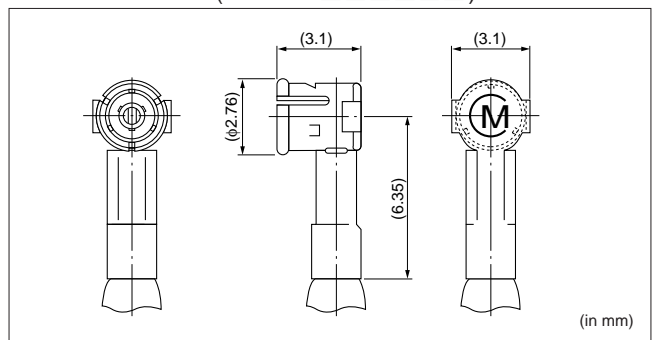

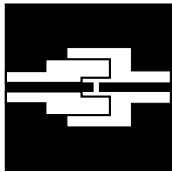

COAXIAL CONNECTOR



SMT CCR Type

■ MATERIALS AND FINISH

● MM4329-2700

Part Name	Materials	Finish
Center Contact	Stainless Steel	Gold plated
Outer Contact	Stainless Steel	Gold plated
Insulator	Polyphenylene Sulfide	None

● MXSG63

Part Name	Materials	Finish
Center Contact	Beryllium Copper	Gold plated
Outer Contact	Phosphor Bronze	Gold plated and Nickel plated
Insulator	Fiber Reinforced Polypropylene	None

■ PART NUMBERING FOR CABLE ASSEMBLY

(Please specify the part number when ordering.)



- ① Cable assembly
- ②④ Connector code

Code	Connector
SG	CCR type Plug connector
XX	None

③ Cable code (See cable list on page 23 to 24 for detail.)

Code	Cable	Outer Diameter	Outer conductor construction	Insulation material	Minimum Bending radius
63	0.8D (*)	2.0mm	Single shield	Cross-linked Polyethylene	8mm
75	0.8D (*)	1.5mm	Double shield	FEP	8mm

(*) Based on Japanese Industrial Standard (JIS).

- ⑤⑥ Full length of cable assembly
 Length (mm) = ⑤×10^⑥
 Ex. : 500mm =500×10⁰→5000
 1000mm =100×10¹→1001

■ CABLE LENGTH TOLERANCE

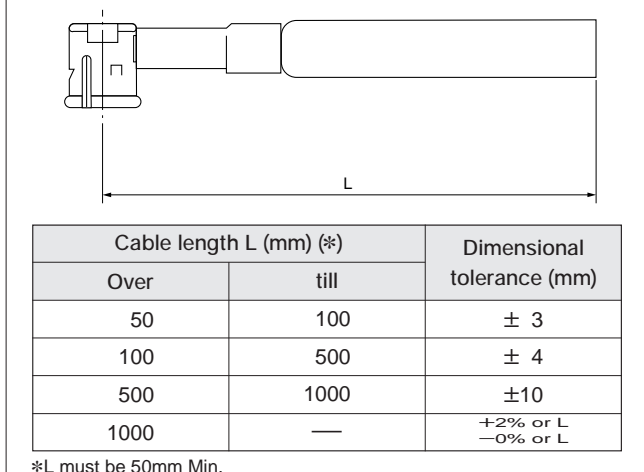

Cable length L (mm) (*)		Dimensional tolerance (mm)
Over	till	
50	100	± 3
100	500	± 4
500	1000	±10
1000	—	+2% or L -0% or L

*L must be 50mm Min.

■ SMA-CCR ADAPTERS

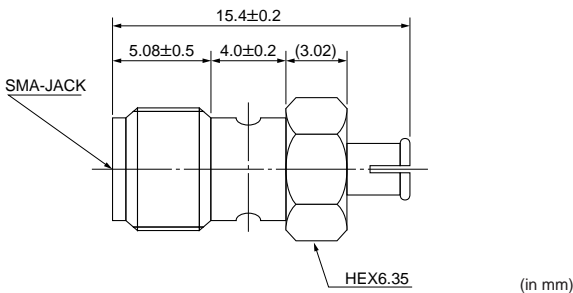
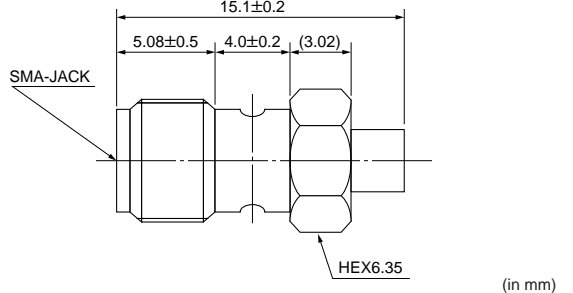
<p>MM121390 (For CCR type receptacle)</p>  <p style="text-align: right;">(in mm)</p>	<p>MM121400 (For CCR type cable assembly)</p>  <p style="text-align: right;">(in mm)</p>
---	--

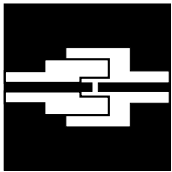

COAXIAL CONNECTOR



SMT CCR Type

NOTICE

Disaccord with following notes could give mechanical damage and/or poor electrical performance.

1. Mechanical Stress :
Stress to the connector should be limited as shown Fig.1.
2. PCB mount pattern dimension :
Dimensions shown in Fig.2 and Fig. 3 should be used for the PCB design.
3. Engagement :
Insertion should be made straight to the axis of the connector.
4. Disengagement :
Use tool P/N M17000. The connector to be disengaged should be pulled out to the vertical direction. Do not try to pull out by the cable.
5. Cable and connector handling :
Do not give a twisted torque to the cable and connector.
6. Reflow soldering condition :
Reflow soldering conditions should be used as shown Fig.5. And the eutectic solder should be used.
7. When MM4329-2700 was soldered on P.C.B.,
 - Use Rosin based flux, but not with strong acid flux (Chlorine content should be less than 0.20wt%).
 - Flux should be cleaned thoroughly.
8. Washing :
In case of cleaning the receptacle, please dry out the receptacle immediately after cleaning. Do not wash cable assembly.
9. Storage of temperature and humidity.
Temperature: -10 to +40°C
Humidity : 30-80%RH

PATTERN DIMENSION (Fig. 2)

For the microstrip line

Legend:
 [Hatched] : LAND
 [Cross-hatched] : ELECTRODE

- The material of P.C.B. is the epoxy resin of glass fabric base. ($\epsilon_r = 4.8$)
- The solder resist should be printed except for the land pattern on the P.C.B.

Thickness of P.C.B. (mm)	A (mm)	B (mm)
0.8	2.14	1.44
1.0	1.82	1.80
1.2	1.71	2.16
1.6	1.62	2.88
2.0	1.59	3.60

STRESS TO THE CONNECTOR (Fig. 1)

1. Stress to the housing
Stress A and B : 9.8N (1kgf) Max.
2. Stress to the outer sleeve.
Stress C : 2.94N (0.3kgf) Max.
Stress D : 1.96N (0.2kgf) Max.
3. Cable pull strength.
Stress E : 14.7N (1.5kgf) Max.

(in mm)

PATTERN DIMENSION (Fig. 3)

For the coplaner line

Legend:
 [Hatched] : LAND
 [Cross-hatched] : ELECTRODE

- The material of P.C.B. is the epoxy resin of glass fabric base. ($\epsilon_r = 4.8$)
- The solder resist should be printed except for the land pattern on the P.C.B.

Thickness of P.C.B. (mm)	L1 (mm)	L2 (mm)
0.8	0.47	0.14
1.0	0.31	0.15
1.2	0.25	0.16
1.6	0.21	0.16
2.0	0.20	0.16

- L1 is for the P.C.B. which has the earth pattern in the opposite side.
- L2 is for the P.C.B. which doesn't have the earth pattern in the opposite side

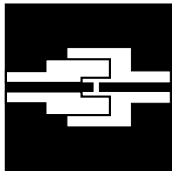

COAXIAL CONNECTOR



SMT CCR Type

DISENGAGEMENT TOOL (Fig. 4)

M17000

(in mm)

How to use disengagement tool

STANDARD REFLOW SOLDERING CONDITIONS (Fig. 5)

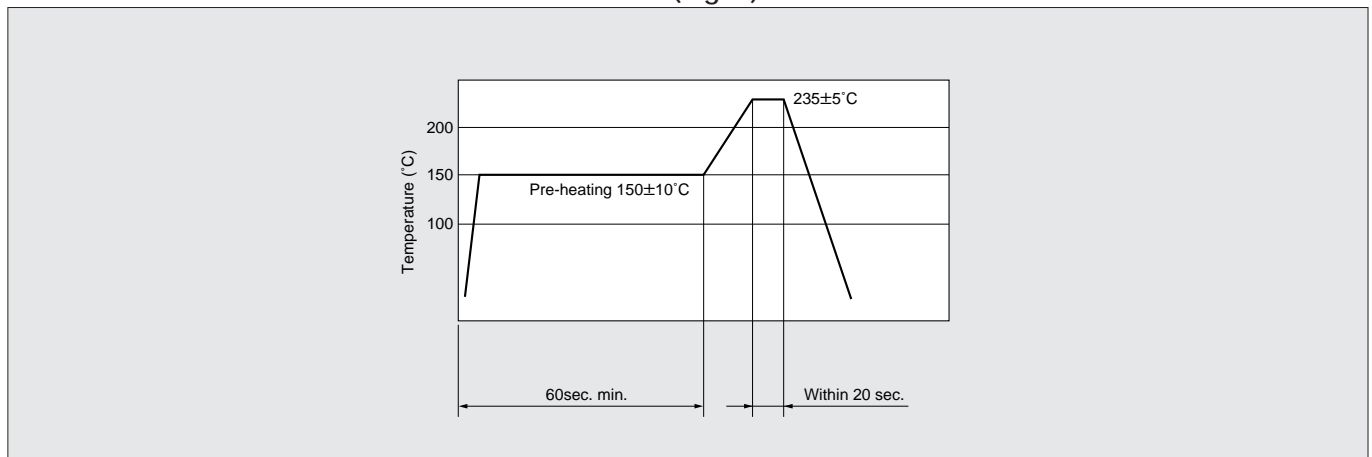

DIMENSIONS OF PLASTIC TAPE (Fig. 6)

Direction of terminal

Hot terminal side

Earth terminal side

Feeding direction

* mark (6 points) are the bottom dimensions of the cavity.

(in mm)

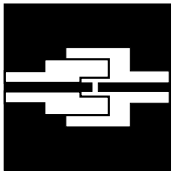

COAXIAL CONNECTOR



Coaxial Connector BFA Type

Discrete type. Easily Handling. Strong Engage Force.

FEATURES

1. Ultra-miniature and low profile (6.3mm Max.)
2. High performance (VSWR 1.2Max. at 4GHz)
3. Very reasonable price for commercial applications.
4. Cable assembly applicable.
5. Low RF leakage
6. Available for ultra-thin coaxial cables.

APPLICATIONS

Portable telephones, mobile telephones, cordless telephones, oscilloscope, GPS, and any other R.F. circuits for microwave equipment.

PART NUMBER

Part Number	Description	Contact
MM3325-2505	Straight receptacle used on printed circuit board	Male
MM3325-2507	Straight receptacle with insulation spacer used on printed circuit board	Male
MM3326-2506	Right angle receptacle used on printed circuit board	Male
MX YH □ □ □ □ □ □ □ □	Right angle cable assembly with flexible cable	Female

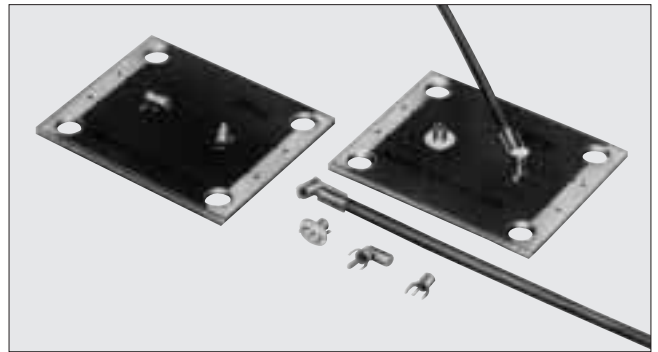

DIMENSIONS

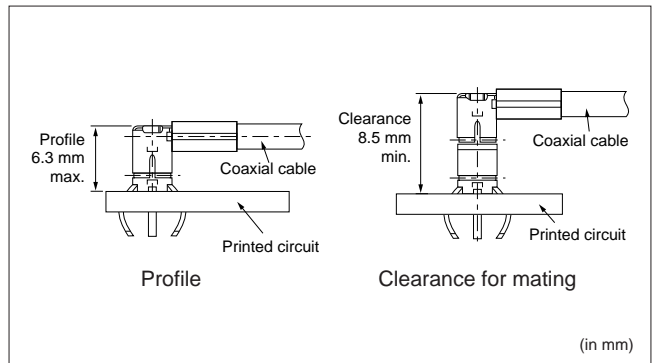

PART NUMBERING FOR CABLE ASSEMBLY

(Please specify the part number when ordering.)

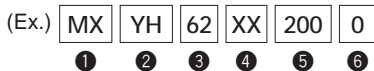

- ① Cable assembly
- ②④ Connector code

Code	Connector
YH	BFA type Plug connector
XX	None

③ Cable code (See cable list on page 23 to 24 for detail.)

Code	Cable	Outer Diameter	Outer conductor construction	Insulation material	Minimum Bending radius
62	0.8D (*)	2.5mm	Double shield	Cross-linked Polyethylene	10mm
63	0.8D (*)	2.0mm	Single shield	Cross-linked Polyethylene	8mm
75	0.8D (*)	1.5mm	Double shield	FEP	8mm

(*) Based on Japanese Industrial Standard (JIS).

⑤⑥ Full length of cable assembly

Length (mm) = ⑤ × 10^⑥

Ex. : 100mm = 100 × 10⁰ → 1000

500mm = 500 × 10¹ → 5000

1000mm = 100 × 10¹ → 1001

CABLE LENGTH TOLERANCE

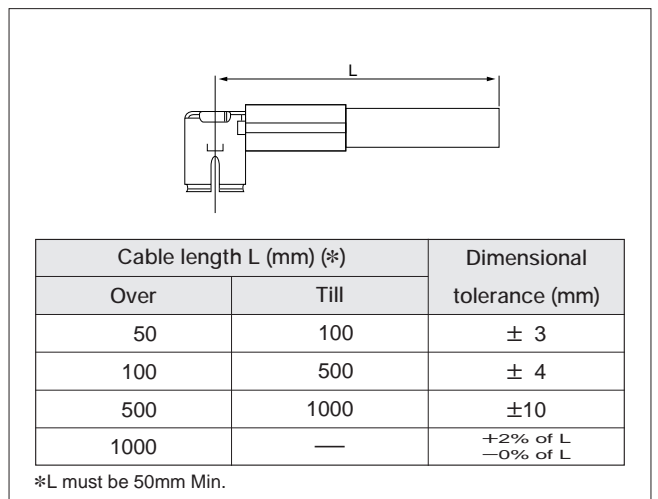

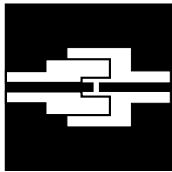

COAXIAL CONNECTOR



Coaxial Connector BFA Type

■ RATING AND CHARACTERISTICS

Item	Specification
Voltage Rating	250Vrms
Frequency Rating and VSWR	DC to 4GHz 1.2 Max.
	DC to 2GHz 1.2 Max. (MM3326-2506)
Nominal Impedance	50Ω
Temperature Range	-40°C to +90°C
Insulation Resistance	1000MΩ Min.
Contact Resistance	10mΩ Max.
Withstanding Voltage	AC300Vrms
Durability	50 cycles

■ MATERIALS AND FINISH

Part Name	Materials	Finish
Center Contact	Beryllium copper or Brass	Gold plated
Outer Contact	Phosper bronze	Silver plated and Nickel plated
Insulator	Poly-phenylene Sulfide	None
Insulation Plate	Poly-butylen terephthalate	None
Spacer (MM3325-2507)	TFE Fluorocarbon	None
Outer Sleeve	Brass	Zinc plated

■ VSWR TYPICAL DATA

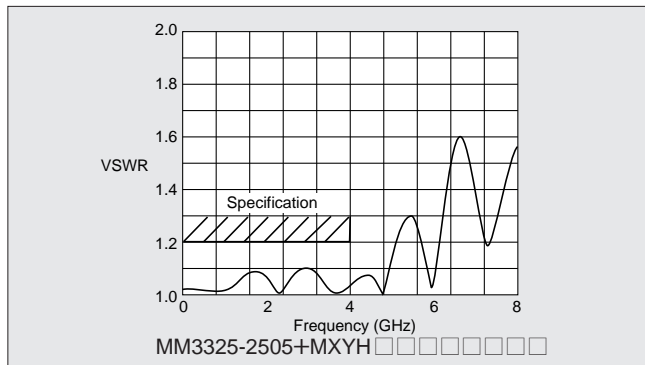

■ R.F. LEAKAGE TYPICAL DATA

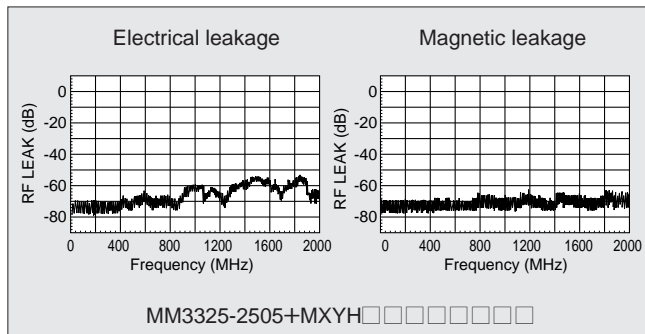

■ DIMENSIONS (MM3325-2505)

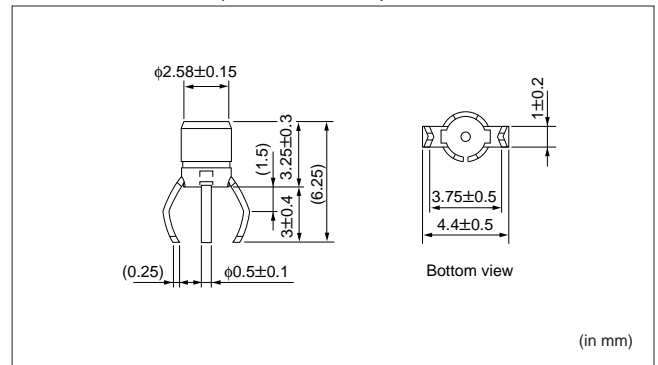

■ DIMENSIONS (MM3325-2507)

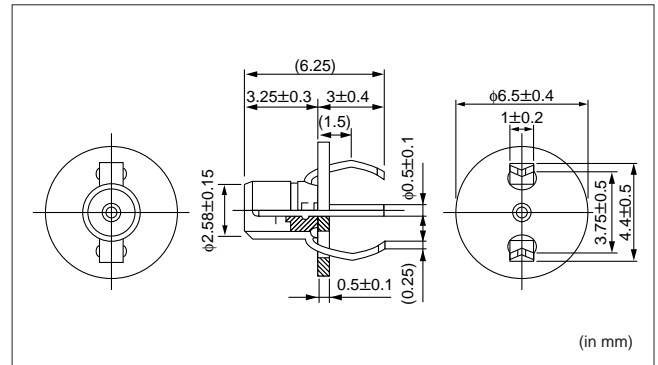

■ DIMENSIONS (MM3326-2506)

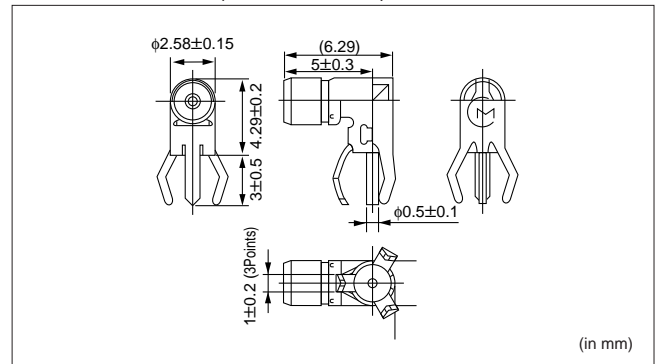

■ DIMENSIONS (MXYH

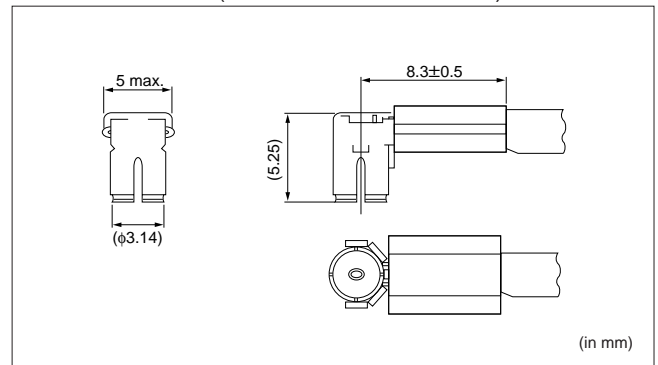

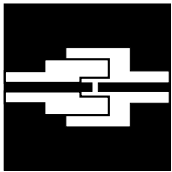

COAXIAL CONNECTOR



Coaxial Connector BFA Type

NOTICE

If this notice is not kept, it has possible that the mating portion or the cable cramping portion is destroyed.

1. P.C.B. mount pattern dimension :
Dimensions shown in Fig. 1 and Fig. 2 should be used for the P.C.B. design.
2. Stress limit to the connector :
When connected, stress to the connector should be limited as show Fig.3.
3. Insertion should be made straight to the axis of the connector.
4. Disengagement :
Use tool P/N M16000 or M16001. The connector to be disengaged should be pulled out to the vertical direction. Do not try to pull out by the cable.
5. Cable and connector handling :
Do not give a twisted torque to the cable and connector.
6. When MM3325-2505, MM3325-2507 and MM3326-2506 were soldered on P.C.B.,
 - Use Rosin based flux, but not strong acid flux (with chlorine content exceeding 0.20wt%).
 - Flux should not be left inside of product.
7. Washing :
In case of cleaning the receptacle, please dry out the receptacle immediately after cleaning. Do not wash cable assembly.
8. Storage of product
Temperature: -10 to +40°C
Humidity : 30 - 80%RH

MOUNTING DIMENSION (Fig. 1)

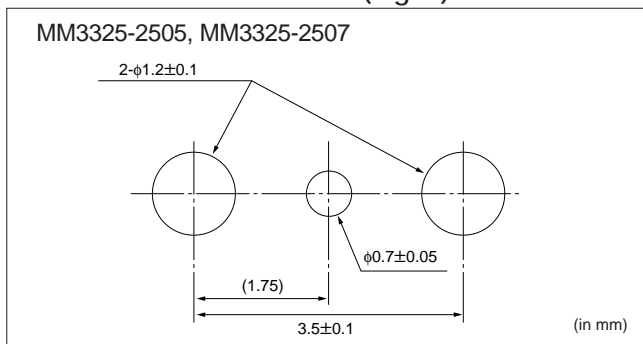

MOUNTING DIMENSION (Fig. 2)

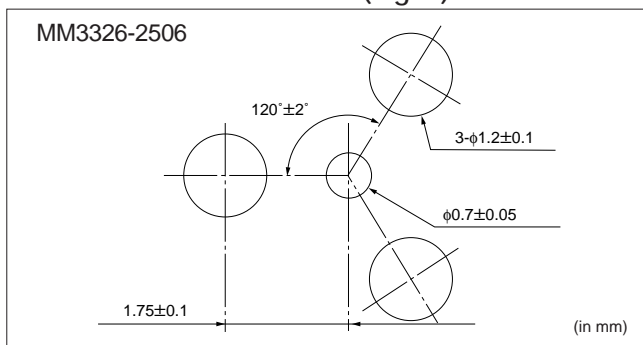

STRESS TO THE CONNECTOR (Fig. 3)

1. Stress to the housing.
Stress A : 9.8N (1kgf) Max.

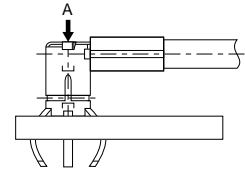

2. Stress to the outer sleeve.
Stress B : 4.9N (0.5kgf) Max.
Stress C : 2.94N (0.3kgf) Max.

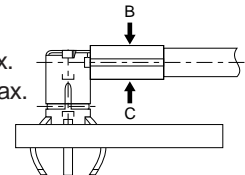

3. Stress to the cable.
Stress D : 9.8N (1kgf)Max.

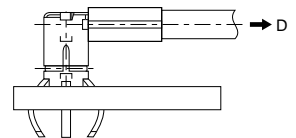

HOW TO USE DISENGAGEMENT TOOLS (Fig. 4)

M16000

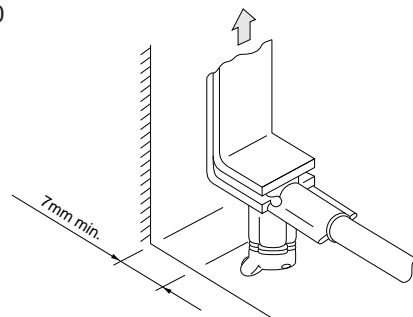

M16001

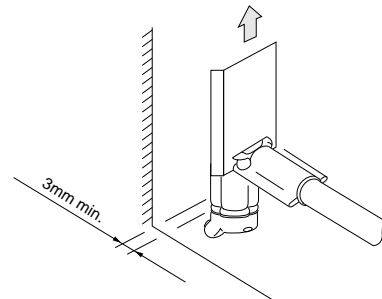

M16001 allows a narrower space (3mm) between the connector and adjacent obstacle. See Fig. 5 for the detail.

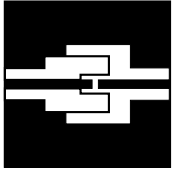

COAXIAL CONNECTOR



Coaxial Connector **BFA** Type

DISENGAGEMENT TOOLS (Fig. 5)

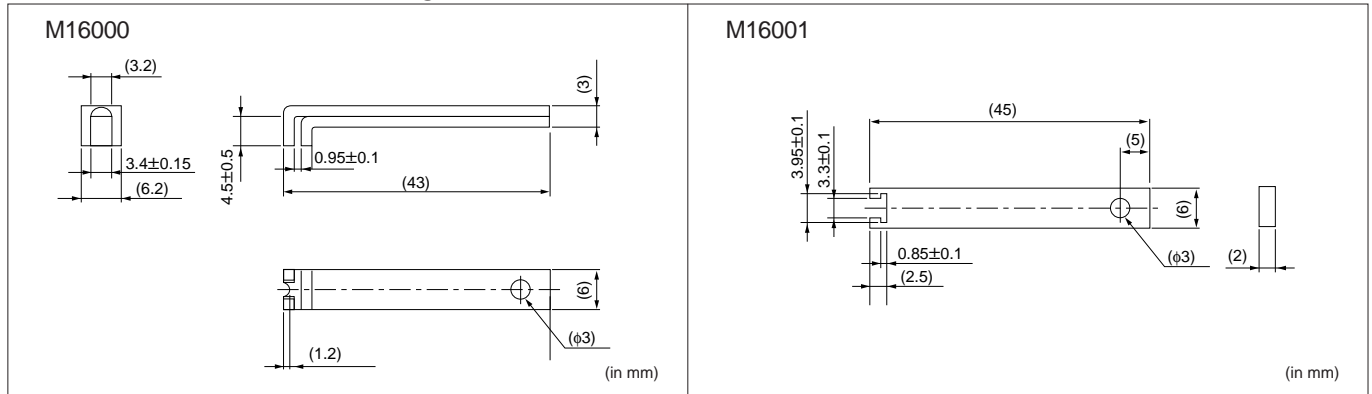

SMA-BFA ADAPTERS (Fig. 6)

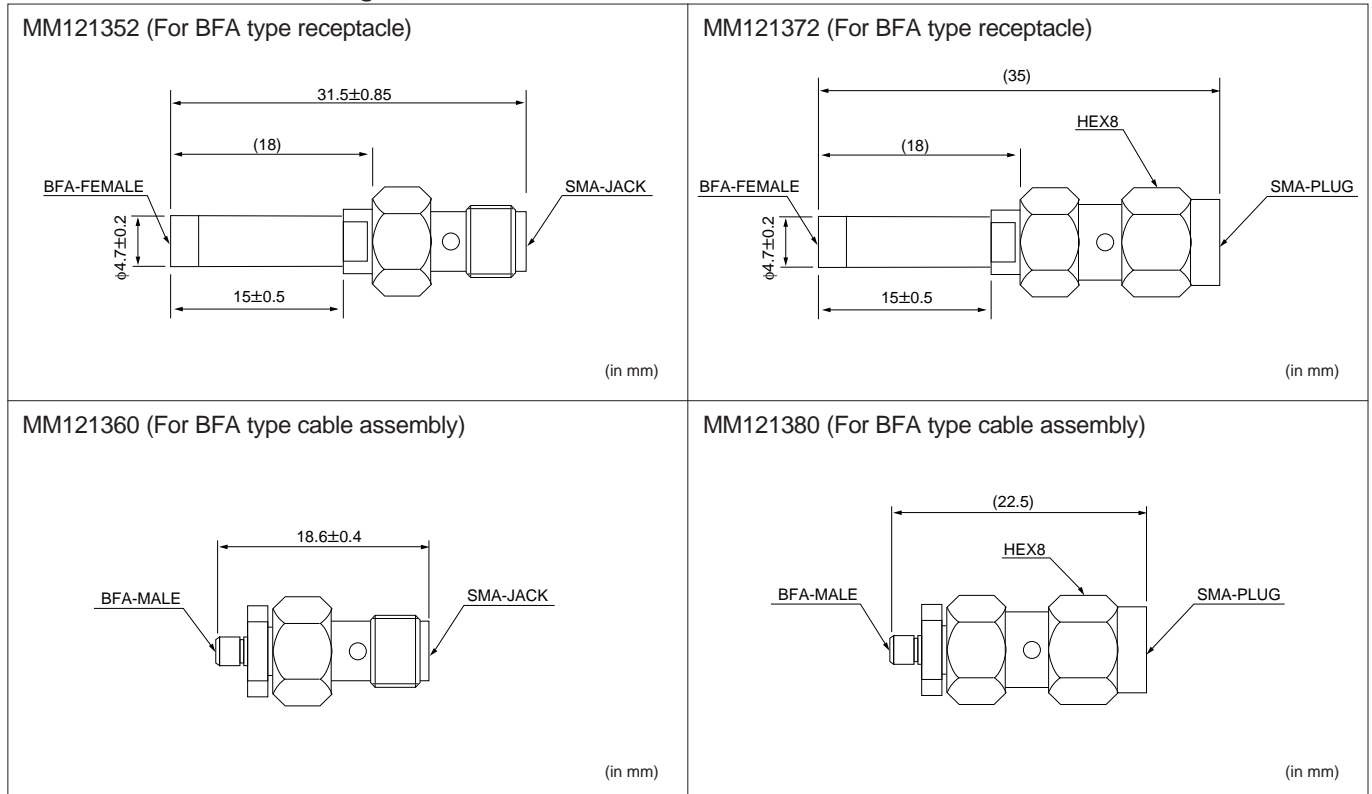

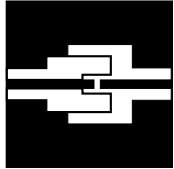

COAXIAL CONNECTOR



Miniaturized micro wave coaxial connector Cable list

			0.8D double shield Cross linked polyethylene cable	0.8D single shield Cross linked polyethylene cable	0.8D double shield FEP cable	0.8D single shield FEP cable
Murata cable code			62	63	75	76
Inner conductor	Material	—	copper covered steel wire	copper covered steel wire	Silver coated copper covered steel wire	Silver coated copper covered steel wire
	No. and Dia.	(No./mm)	1/0.26	1/0.26	1/0.26	1/0.26
	Total Dia.	(mm)	0.26	0.26	0.26	0.26
Insulator	Material	—	Cross linked polyethylene compound	Cross linked polyethylene compound	FEP	FEP
	Melting point (Reference only)	Degree C	230	230	285	285
	Total Dia.	(mm)	0.8	0.8	0.8	0.8
Outer conductor	Material	—	Bare copper wire	Bare copper wire	Tin plated copper wire	Tin plated copper wire
	Dia. of wire	(mm)	0.1	0.1	0.05	0.05
	Total Dia.	(mm)	Inner 1.3 Outer 1.8	1.3	Inner 1.05 Outer 1.3	1.05
Sheath	Material	—	Polyvinyl chloride compound	Polyvinyl chloride compound	FEP	FEP
	Nominal thickness	(mm)	0.35	0.35	0.1	0.1
	Color	—	Gray	Gray	Gray	Gray
Overall Dia.		(mm)	2.5	2	1.5	1.24
Minimum bending radius		(mm)	10	8	8	6
Nominal impedance		(Ohm)	50	50	50	50
Continuous operating voltage			300 Vrms Max.	300 Vrms Max.	300 Vrms Max.	300 Vrms Max.
Nominal static capacitance		(pF/m)	100	100	100	100
Insertion loss	Nominal					
	dB/m at 1GHz		1.6	1.6	1.56	1.56
	dB/m at 2GHz		2.3	2.3	2.3	2.3
	dB/m at 3GHz		2.8	2.8	2.9	2.9
	dB/m at 4GHz		3.2	3.2	3.5	3.5
dB/m at 6GHz						
Assembly to BFA			Suitable	Suitable	Suitable	Not Suitable
Assembly to CCR			Not Suitable	Suitable	Suitable	Not Suitable
Assembly to FSC			Not Suitable	Not Suitable	Not Suitable	Suitable
Assembly to GSC			Not Suitable	Not Suitable	Not Suitable	Not Suitable

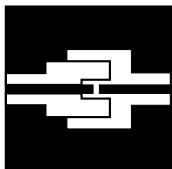

COAXIAL CONNECTOR

Miniaturized micro wave coaxial connector Cable list

			0.4D single shield FEP cable	0.4D single shield PFA cable	0.52D Semi rigid Cable	0.4D single shield PFA cable
Murata cable code			81	88	91	92
Inner conductor	Material	—	Silver coated copper covered alloy wire	Silver coated copper covered steel wire	Silver coated copper covered steel wire	Silver coated copper covered alloy wire
	No. and Dia.	(No./mm)	7/0.05	1/0.15	1/0.162	7/0.05
	Total Dia.	(mm)	0.15	0.15	0.162	0.15
Insulator	Material	—	FEP	PFA	PTFE	PFA
	Melting point (Reference only)	Degree C	250	302 – 310	327	302 – 310
	Total Dia.	(mm)	0.4	0.43	0.52	0.4
Outer conductor	Material	—	Tin plated copper wire	Tin plated copper wire	Solder plated copper wire	Tin plated copper wire
	Dia. of wire	(mm)	0.05	0.05	—	0.05
	Total Dia.	(mm)	0.65	0.68	0.62	0.65
Sheath	Material	—	FEP	PFA	—	PFA
	Nominal thickness	(mm)	0.05	0.075	—	0.075
	Color	—	White	White	—	White
Overall Dia.		(mm)	0.8	0.83	0.62	0.8
Minimum bending radius		(mm)	4.8	3.3	3.2	3.3
Nominal impedance		(Ohm)	50	50	50	50
Continuous operating voltage			300 Vrms Max.	300 Vrms Max.	300 Vrms Max.	300 Vrms Max.
Nominal static capacitance		(pF/m)	100	100	100	100
Nominal Insertion loss	dB/m at 1GHz		3	2.89	2.3	3
	dB/m at 2GHz		4.26	4.28	3.2	4.26
	dB/m at 3GHz		5.24	5.39	3.9	5.24
	dB/m at 4GHz		6.18	6.44	4.900 (5GHz)	6.18
	dB/m at 6GHz			8.4		9.17
Assembly to BFA			Not Suitable	Not Suitable	Not Suitable	Not Suitable
Assembly to CCR			Not Suitable	Not Suitable	Not Suitable	Not Suitable
Assembly to FSC			Suitable	Suitable	Suitable	Suitable
Assembly to GSC			Suitable	Suitable	Suitable	Suitable

⚠ Note:**1. Export Control**

⟨For customers outside Japan⟩

Murata products should not be used or sold for use in the development, production, stockpiling or utilization of any conventional weapons or mass-destructive weapons (nuclear weapons, chemical or biological weapons, or missiles), or any other weapons.

⟨For customers in Japan⟩

For products which are controlled items subject to the "Foreign Exchange and Foreign Trade Law" of Japan, the export license specified by the law is required for export.

2. Please contact our sales representatives or product engineers before using our products listed in this catalog for the applications listed below which require especially high reliability for the prevention of defects which might directly cause damage to the third party's life, body or property, or when intending to use one of our products for other applications than specified in this catalog.

- ① Aircraft equipment
- ② Aerospace equipment
- ③ Undersea equipment
- ④ Medical equipment
- ⑤ Transportation equipment (vehicles, trains, ships, etc.)
- ⑥ Traffic signal equipment
- ⑦ Disaster prevention / crime prevention equipment
- ⑧ Data-processing equipment
- ⑨ Application of similar complexity and/or reliability requirements to the applications listed in the above

3. Product specifications in this catalog are as of September 1999. They are subject to change or our products in it may be discontinued without advance notice. Please check with our sales representatives or product engineers before your ordering. If there are any questions, please contact our sales representatives or product engineers.**4. The parts numbers and specifications listed in this catalog are for information only. You are requested to approve our product specification or to transact the approval sheet for product specification, before your ordering.****5. Please note that unless otherwise specified, we shall assume no responsibility whatsoever for any conflict or dispute that may occur in connection with the effect of our and/or third party's intellectual property rights and other related rights in consideration of your using our products and/or information described or contained in our catalogs. In this connection, no representation shall be made to the effect that any third parties are authorized to use the rights mentioned above under licenses without our consent.****6. None of ozone depleting substances (ODS) under the Montreal Protocol is used in manufacturing process of us.**