



# UTT60N06

*Power MOSFET*

## N-CHANNEL ENHANCEMENT MODE POWER MOSFET

### DESCRIPTION

The UTC **UTT60N06** is n-channel enhancement mode power field effect transistors with stable off-state characteristics, fast switching speed and low thermal resistance. usually used at telecom and computer applications.

### FEATURES

- \*  $R_{DS(ON)} < 18\text{ m}\Omega @ V_{GS} = 10\text{ V}, I_D = 30\text{ A}$
- \* Fast switching capability
- \* Avalanche energy Specified

### SYMBOL

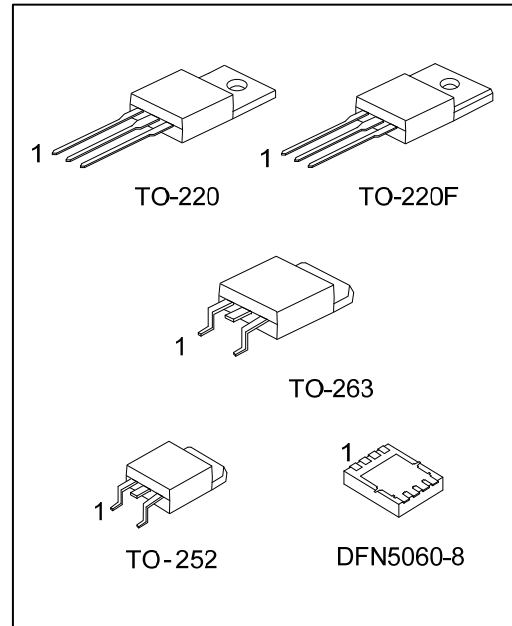
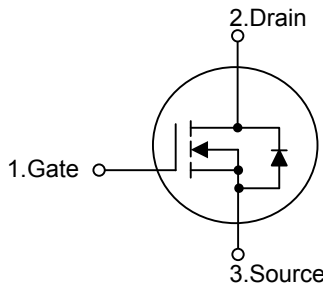

### ORDERING INFORMATION

Ordering Number		Package	Pin Assignment								Packing
Lead Free	Halogen Free		1	2	3	4	5	6	7	8	
UTT60N06L-TA3-T	UTT60N06G-TA3-T	TO-220	G	D	S	-	-	-	-	-	Tube
UTT60N06L-TF3-T	UTT60N06G-TF3-T	TO-220F	G	D	S	-	-	-	-	-	Tube
UTT60N06L-TN3-R	UTT60N06G-TN3-R	TO-252	G	D	S	-	-	-	-	-	Tape Reel
UTT60N06L-TQ2-T	UTT60N06G-TQ2-T	TO-263	G	D	S	-	-	-	-	-	Tube
UTT60N06L-TQ2-R	UTT60N06G-TQ2-R	TO-263	G	D	S	-	-	-	-	-	Tape Reel
UTT60N06L-K08-5060-R	UTT60N06G-K08-5060-R	DFN5060-8	S	S	S	G	D	D	D	D	Tape Reel

Note: Pin Assignment: G: Gate D: Drain S: Source

<p>UTT60N06G-TA3-T</p>	<p>(1) T: Tube, R: Tape Reel                  (2) TA3: TO-220, TF3: TO-220F, TN3: TO-252, TQ2: TO-263, K08-5060: DFN5060-8                  (3) G: Halogen Free and Lead Free, L: Lead Free</p>
------------------------	---

■ MARKING

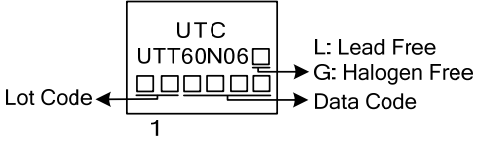
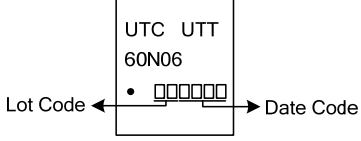
TO-220 / TO-220F TO-252 / TO-263	DFN5060-8
 <p>UTC UTT60N06 Lot Code ← [ ] [ ] [ ] [ ] → Data Code L: Lead Free G: Halogen Free 1</p>	 <p>UTC UTT 60N06 Lot Code ← [ ] [ ] [ ] [ ] • → Date Code</p>

■ ABSOLUTE MAXIMUM RATINGS ( $T_C = 25^\circ\text{C}$ , unless otherwise specified)

PARAMETER		SYMBOL	RATINGS	UNIT
Drain to Source Voltage		$V_{DSS}$	60	V
Gate to Source Voltage		$V_{GS}$	$\pm 20$	V
Continuous Drain Current	$T_C = 25^\circ\text{C}$	$I_D$	60	A
	$T_C = 100^\circ\text{C}$		39	A
Drain Current Pulsed (Note 2)		$I_{DM}$	120	A
Avalanche Energy	Single Pulsed	$E_{AS}$	100	mJ
Power Dissipation ( $T_C=25^\circ\text{C}$ )	TO-220/TO-263	$P_D$	100	W
	TO-220F		70.62	W
	TO-252		70	W
	DFN5060-8		88	W
Junction Temperature		$T_J$	+150	$^\circ\text{C}$
Storage Temperature		$T_{STG}$	-55 ~ +150	$^\circ\text{C}$

Notes: 1. Absolute maximum ratings are those values beyond which the device could be permanently damaged.

Absolute maximum ratings are stress ratings only and functional device operation is not implied.

2. Repeativity rating: pulse width limited by junction temperature

■ THERMAL DATA

PARAMETER		SYMBOL	RATINGS	UNIT
Junction to Ambient	TO-220/TO-220F	$\theta_{JA}$	62.5	$^\circ\text{C/W}$
	TO-263			
	TO-252			
	DFN5060-8			
Junction to Case	TO-220/TO-263	$\theta_{JC}$	1.25	$^\circ\text{C/W}$
	TO-220F		1.77	$^\circ\text{C/W}$
	TO-252		1.8	$^\circ\text{C/W}$
	DFN5060-8		1.4 (Note)	$^\circ\text{C/W}$

Note: The data tested by surface mounted on a 1 inch<sup>2</sup> FR-4 board with 2OZ copper.

■ ELECTRICAL CHARACTERISTICS ( $T_c = 25^\circ\text{C}$ , unless otherwise specified)

PARAMETER	SYMBOL	TEST CONDITIONS	MIN	TYP	MAX	UNIT
<b>OFF CHARACTERISTICS</b>						
Drain-Source Breakdown Voltage	$BV_{DSS}$	$V_{GS} = 0\text{ V}, I_D = 250\mu\text{A}$	60			V
Drain-Source Leakage Current	$I_{DSS}$	$V_{DS} = 60\text{ V}, V_{GS} = 0\text{ V}$			1	$\mu\text{A}$
Gate-Source Leakage Current	Forward	$V_{GS} = 20\text{ V}, V_{DS} = 0\text{ V}$ $V_{GS} = -20\text{ V}, V_{DS} = 0\text{ V}$			100	nA
	Reverse				-100	nA
<b>ON CHARACTERISTICS</b>						
Gate Threshold Voltage	$V_{GS(TH)}$	$V_{DS} = V_{GS}, I_D = 250\mu\text{A}$	2.0		4.0	V
Static Drain-Source On-State Resistance	$R_{DS(ON)}$	$V_{GS} = 10\text{ V}, I_D = 30\text{ A}$		14	18	$\text{m}\Omega$
<b>DYNAMIC CHARACTERISTICS</b>						
Input Capacitance	$C_{ISS}$	$V_{GS} = 0\text{ V}, V_{DS} = 25\text{ V}, f = 1\text{ MHz}$		2000		pF
Output Capacitance	$C_{OSS}$			400		pF
Reverse Transfer Capacitance	$C_{RSS}$			115		pF
<b>SWITCHING CHARACTERISTICS</b>						
Total Gate Charge	$Q_G$	$V_{DS} = 30\text{ V}, V_{GS} = 10\text{ V}$ $I_D = 60\text{ A}$ (Note 1, 2)		39	60	nC
Gate-Source Charge	$Q_{GS}$			12		nC
Gate-Drain Charge (Miller Charge)	$Q_{GD}$			10		nC
Turn-On Delay Time	$t_{D(ON)}$	$V_{DD} = 48\text{ V}, I_D = 60\text{ A}, V_{GS} = 10\text{ V}$ (Note 1, 2)		12	30	ns
Rise Time	$t_R$			11	30	ns
Turn-Off Delay Time	$t_{D(OFF)}$			25	50	ns
Fall Time	$t_F$			15	30	ns
<b>SOURCE-DRAIN DIODE RATINGS AND CHARACTERISTICS</b>						
Continuous Source Current	$I_S$				60	A
Pulsed Source Current	$I_{SM}$				120	
Diode Forward Voltage	$V_{SD}$	$V_{GS} = 0\text{ V}, I_S = 60\text{ A}$			1.6	V
Reverse Recovery Time	$t_{rr}$	$I_S = 60\text{ A}, V_{GS} = 0\text{ V},$		60		ns
Reverse Recovery Charge	$Q_{rr}$	$di/dt = 100\text{ A}/\mu\text{s}$ (Note 1)		3.4		$\mu\text{C}$

- Notes: 1. Pulse Test: Pulse Width $\leq 300\mu\text{s}$ , Duty Cycle $\leq 2\%$   
 2. Essentially independent of operating temperature.

## TEST CIRCUITS AND WAVEFORMS

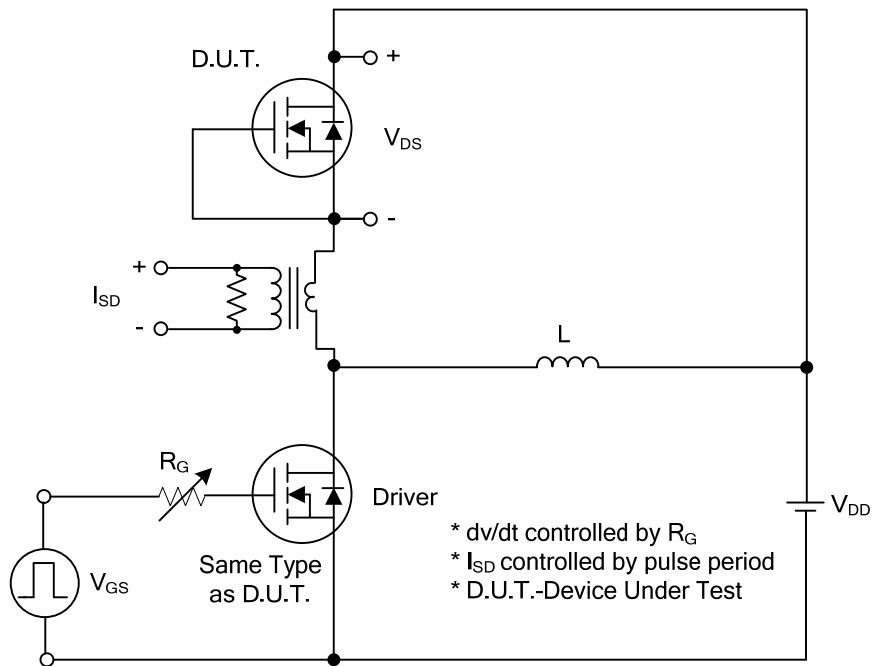

**Peak Diode Recovery dv/dt Test Circuit**

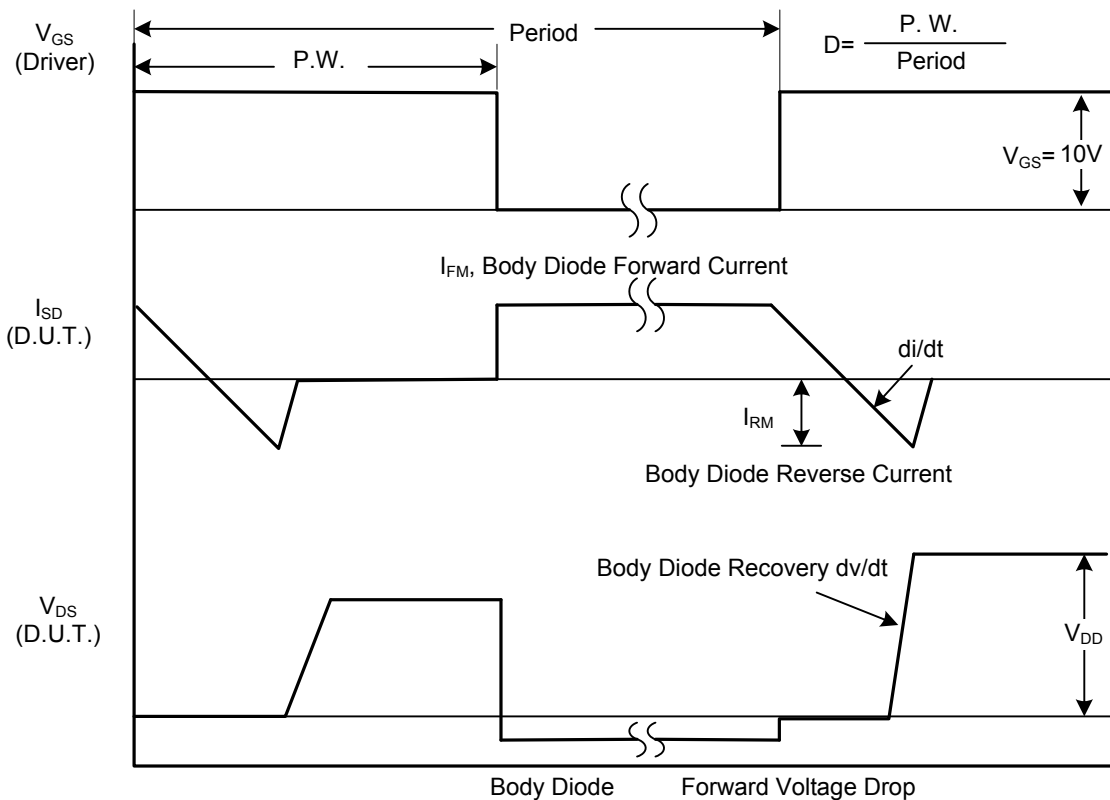

**Peak Diode Recovery dv/dt Waveforms**

## TEST CIRCUITS AND WAVEFORMS

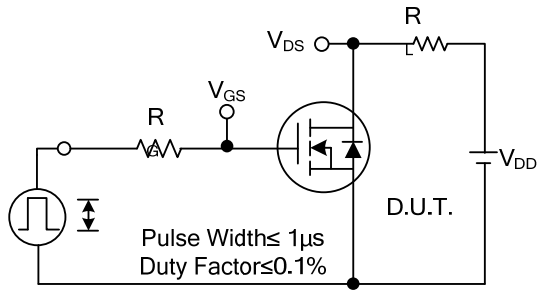

Switching Test Circuit

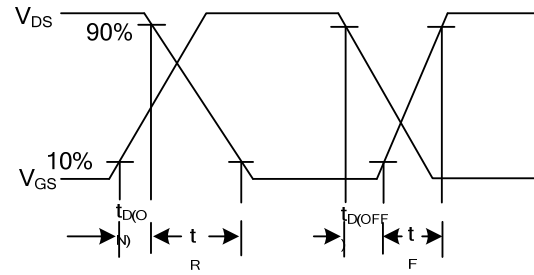

Switching Waveforms

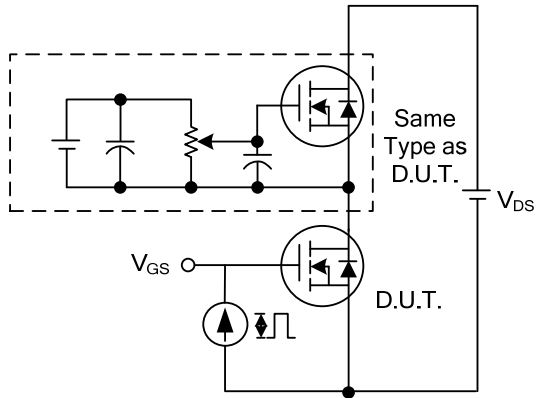

Gate Charge Test Circuit

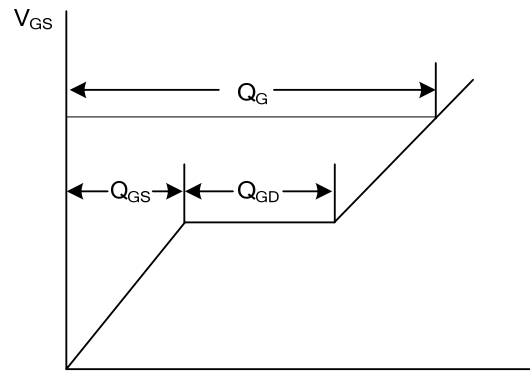

Charge

Gate Charge Waveform

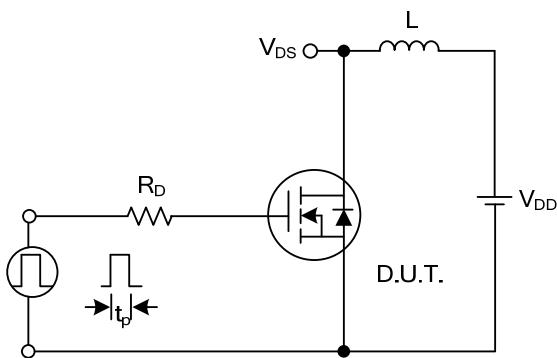

Unclamped Inductive Switching Test Circuit

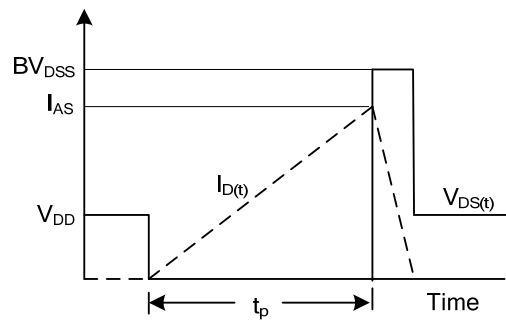

Unclamped Inductive Switching Waveforms

## TYPICAL CHARACTERISTICS

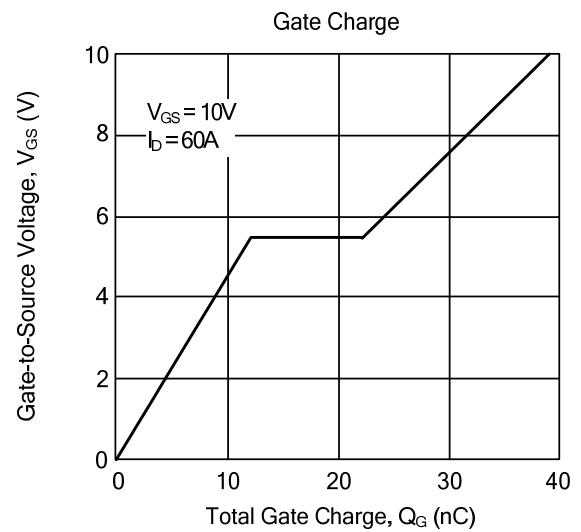
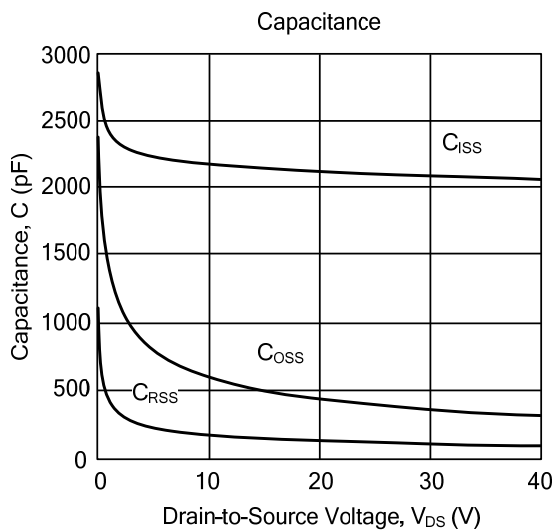
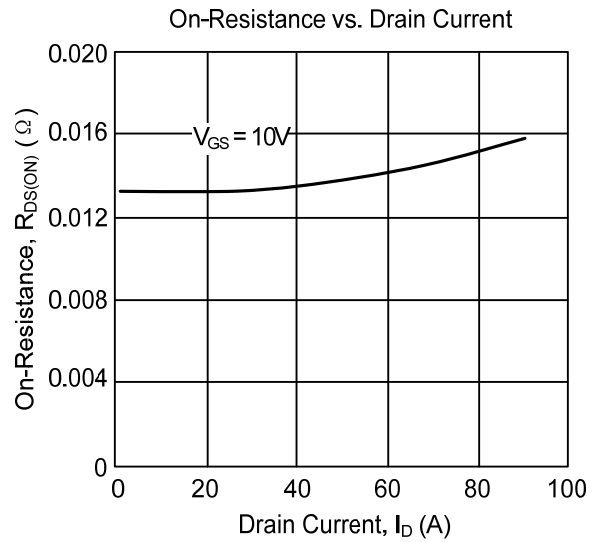
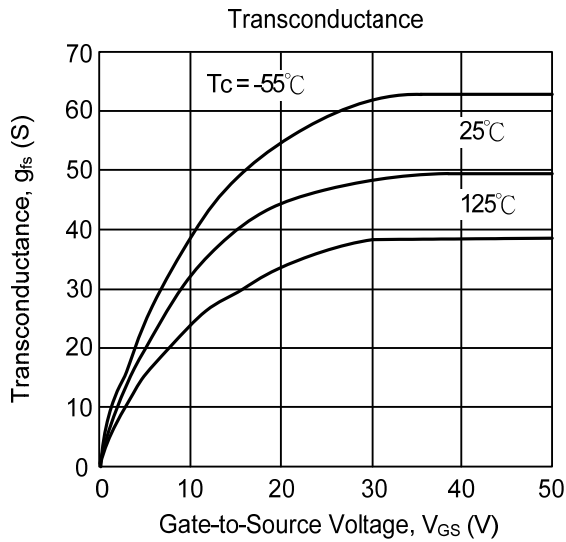
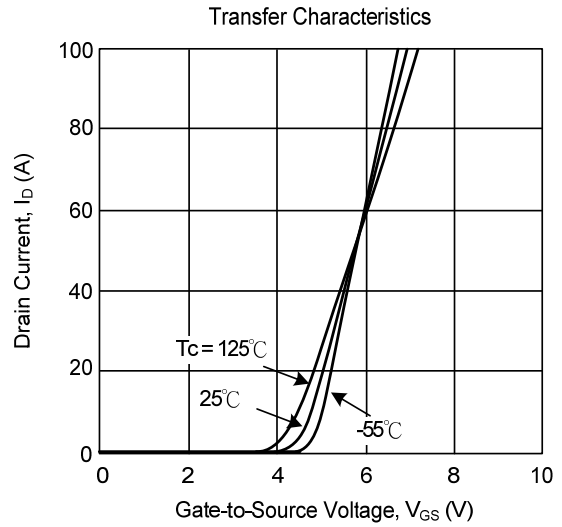
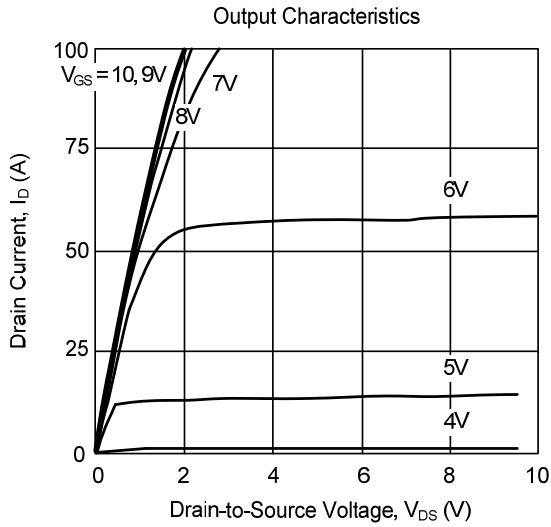

## TYPICAL CHARACTERISTICS (Cont.)

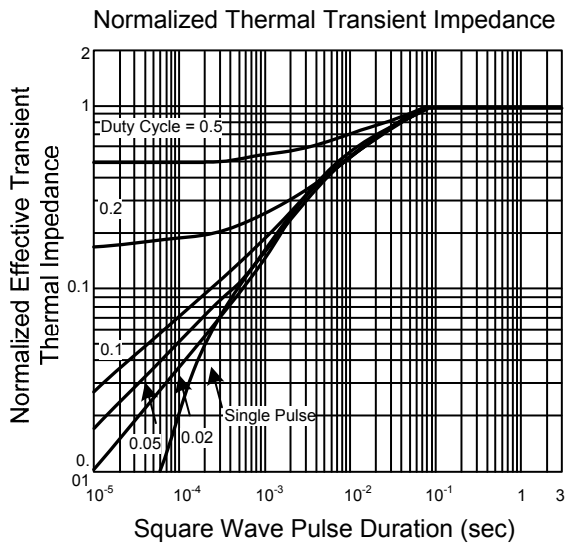
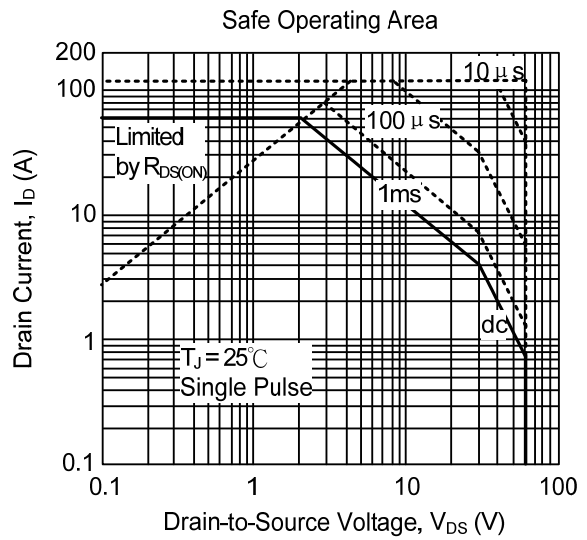
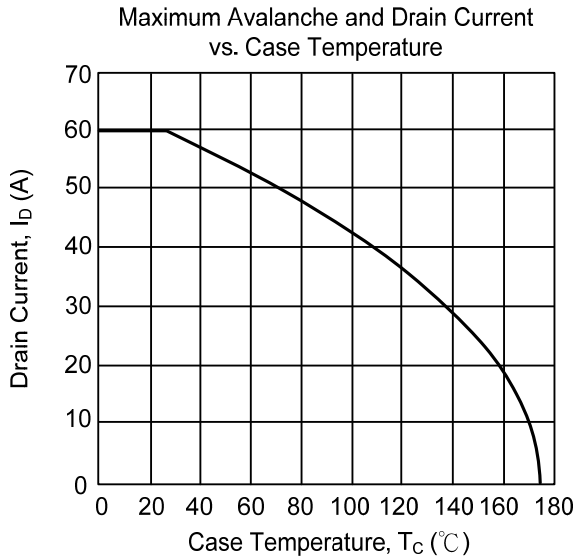
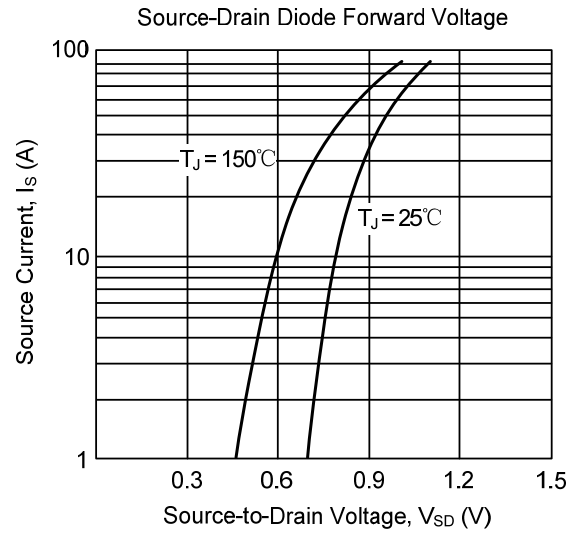
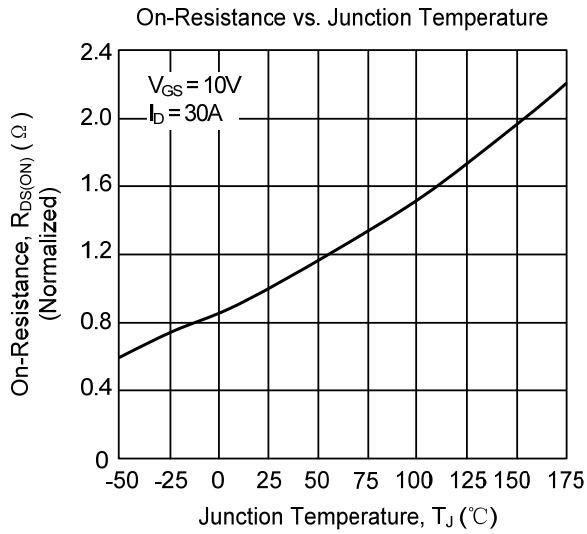



UTC assumes no responsibility for equipment failures that result from using products at values that exceed, even momentarily, rated values (such as maximum ratings, operating condition ranges, or other parameters) listed in products specifications of any and all UTC products described or contained herein. UTC products are not designed for use in life support appliances, devices or systems where malfunction of these products can be reasonably expected to result in personal injury. Reproduction in whole or in part is prohibited without the prior written consent of the copyright owner. UTC reserves the right to make changes to information published in this document, including without limitation specifications and product descriptions, at any time and without notice. This document supersedes and replaces all information supplied prior to the publication hereof.