



UF540

Power MOSFET

27A, 100V N-CHANNEL POWER MOSFET

■ DESCRIPTION

The UTC **UF540** is a N-channel enhancement mode power MOSFET using UTC's advanced technology to provide the customers with a minimum on-state resistance and high switching speed.

■ FEATURES

- * $R_{DS(on)} \leq 36m\Omega$ @ $V_{GS}=10V, I_D=15A$
- * High Switching Speed

■ SYMBOL

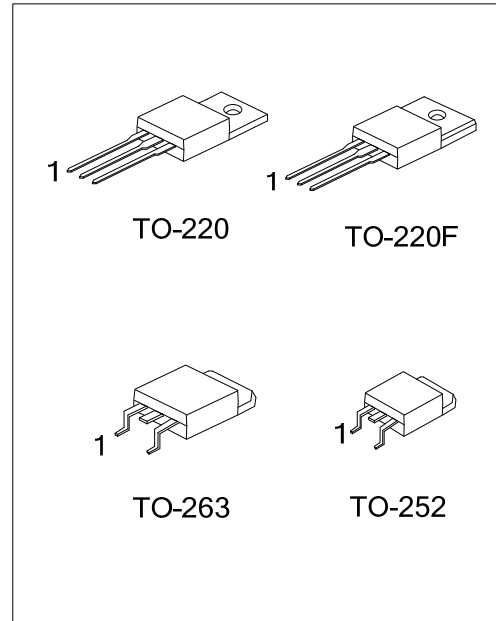
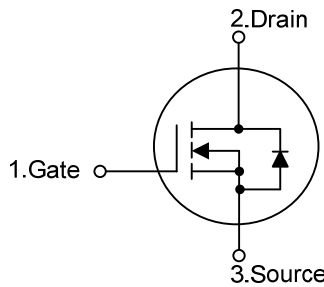

■ ORDERING INFORMATION

Ordering Number		Package	Pin Assignment			Packing
Lead Free	Halogen Free		1	2	3	
UF540L-TA3-T	UF540G-TA3-T	TO-220	G	D	S	Tube
UF540L-TF3-T	UF540G-TF3-T	TO-220F	G	D	S	Tube
UF540L-TN3-R	UF540G-TN3-R	TO-252	G	D	S	Tape Reel
UF540L-TQ2-T	UF540G-TQ2-T	TO-263	G	D	S	Tube
UF540L-TQ2-R	UF540G-TQ2-R	TO-263	G	D	S	Tape Reel

Note: Pin Assignment: G: Gate D: Drain S: Source

<p>UF540G-TA3-T</p>	<p>(1) T: Tube, R: Tape Reel</p> <p>(2) TA3: TO-220, TF3: TO-220F, TN3: TO-252</p> <p>(3) G: Halogen Free and Lead Free, L: Lead Free</p>
---------------------	---

■ MARKING

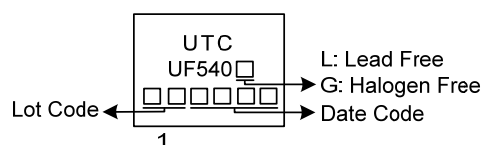

■ ABSOLUTE MAXIMUM RATINGS

PARAMETER		SYMBOL	RATINGS	UNIT	
Drain-Source Voltage (Note 2)		V_{DSS}	100	V	
Gate-Source Voltage		V_{GSS}	± 20	V	
Drain Current	Continuous	I_D	$T_C=25^\circ\text{C}$	27	A
			$T_C=100^\circ\text{C}$	17	A
	Pulsed	I_{DM}	108	A	
Power Dissipation ($T_C=25^\circ\text{C}$)	TO-220	P_D	125	W	
	TO-263		40	W	
	TO-220F		55	W	
	TO-252				
Junction Temperature		T_J	+150	$^\circ\text{C}$	
Storage Temperature		T_{STG}	-55 ~ +150	$^\circ\text{C}$	

Notes: 1. Absolute maximum ratings are those values beyond which the device could be permanently damaged.

Absolute maximum ratings are stress ratings only and functional device operation is not implied.

2. $T_J = +25 \sim +150^\circ\text{C}$

■ THERMAL DATA

PARAMETER		SYMBOL	RATINGS	UNIT
Junction to Case	TO-220	θ_{JC}	1.0	$^\circ\text{C/W}$
	TO-263		3.125	$^\circ\text{C/W}$
	TO-220F		2.27	$^\circ\text{C/W}$
	TO-252			

■ ELECTRICAL CHARACTERISTICS ($T_C=25^\circ\text{C}$, unless otherwise noted)

PARAMETER		SYMBOL	TEST CONDITIONS	MIN	TYP	MAX	UNIT
OFF CHARACTERISTICS							
Drain-Source Breakdown Voltage		BV_{DSS}	$I_D=250\mu\text{A}, V_{GS}=0\text{V}$	100			V
Drain-Source Leakage Current		I_{DSS}	$V_{DS}=100\text{V}, V_{GS}=0\text{V}$			1	μA
Gate-Source Leakage Current	Forward	I_{GSS}	$V_{GS}=+20\text{V}, V_{DS}=0\text{V}$			100	nA
	Reverse		$V_{GS}=-20\text{V}, V_{DS}=0\text{V}$			-100	nA
ON CHARACTERISTICS							
Gate Threshold Voltage		$V_{GS(TH)}$	$V_{DS}=V_{GS}, I_D=250\mu\text{A}$	2.0		4.0	V
Static Drain-Source On-State Resistance		$R_{DS(ON)}$	$V_{GS}=10\text{V}, I_D=15\text{A}$			36	m Ω
DYNAMIC PARAMETERS							
Input Capacitance		C_{ISS}	$V_{GS}=0\text{V}, V_{DS}=25\text{V}, f=1.0\text{MHz}$		1620		pF
Output Capacitance		C_{OSS}			280		pF
Reverse Transfer Capacitance		C_{RSS}			48		pF
SWITCHING PARAMETERS							
Total Gate Charge		Q_G	$V_{DD}=80\text{V}, V_{GS}=10\text{V}, I_D=27\text{A}$		42		nC
Gate to Source Charge		Q_{GS}			8		nC
Gate to Drain Charge		Q_{GD}			15		nC
Turn-ON Delay Time		$t_{D(ON)}$	$V_{DD}=50\text{V}, V_{GS}=10\text{V}, I_D=27\text{A}, R_{GEN}=25\Omega$ (Fig.1, 2) (Note 2)		22		ns
Rise Time		t_R			32		ns
Turn-OFF Delay Time		$t_{D(OFF)}$			123		ns
Fall-Time		t_F			32		ns
SOURCE- DRAIN DIODE RATINGS AND CHARACTERISTICS							
Maximum Body-Diode Continuous Current		I_S				27	A
Maximum Body-Diode Pulsed Current		I_{SM}				108	A
Drain-Source Diode Forward Voltage		V_{SD}	$I_S=27\text{A}, V_{GS}=0\text{V}$			1.4	V
Body Diode Reverse Recovery Time		t_{rr}	$I_S=4.0\text{A}, dI_S/dt=25\text{A}/\mu\text{s}$		300		ns

Notes: 1. Pulse Test : Pulse width $\leq 300\mu\text{s}$, Duty cycle $\leq 2\%$.

2. Essentially independent of operating ambient temperature.

■ TEST CIRCUITS AND WAVEFORMS

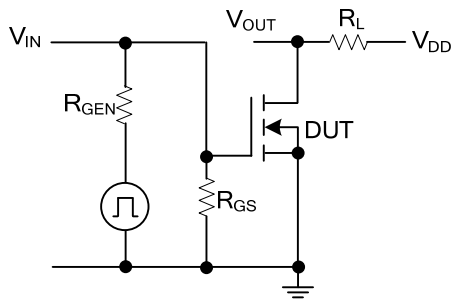

Fig.1 Switching Test Circuit

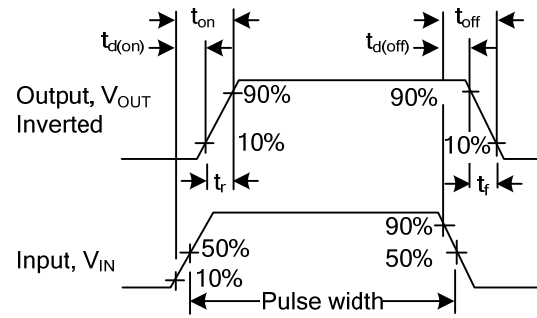
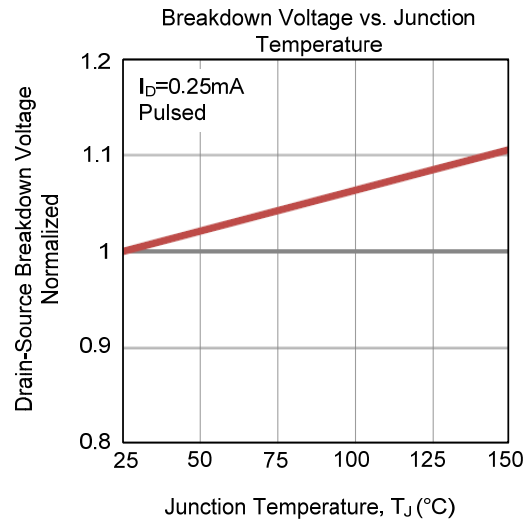
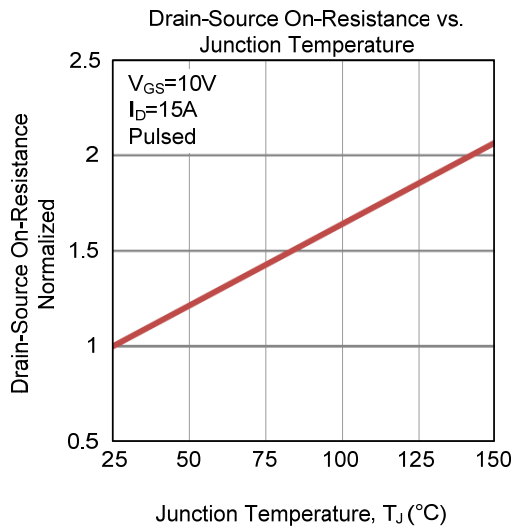
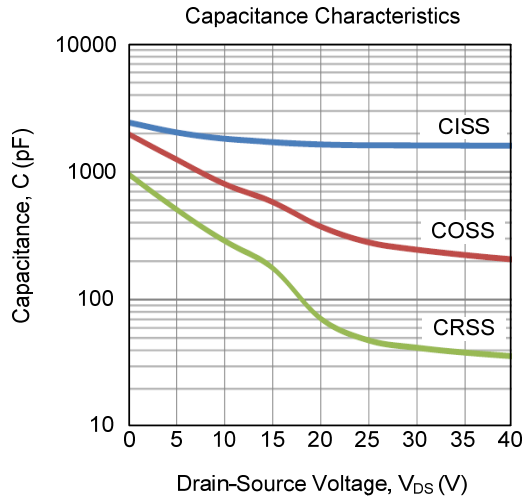
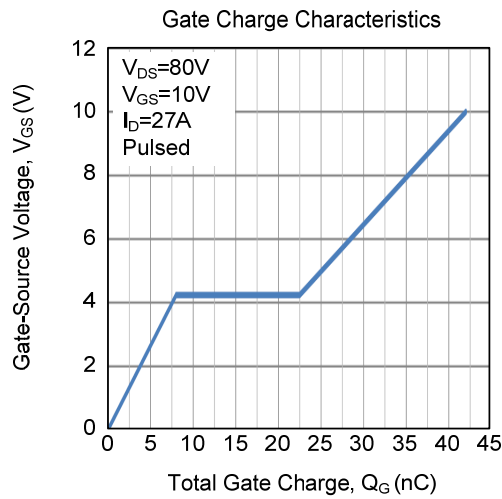
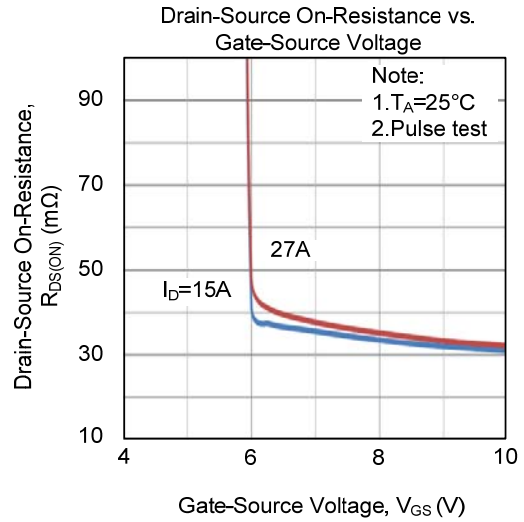
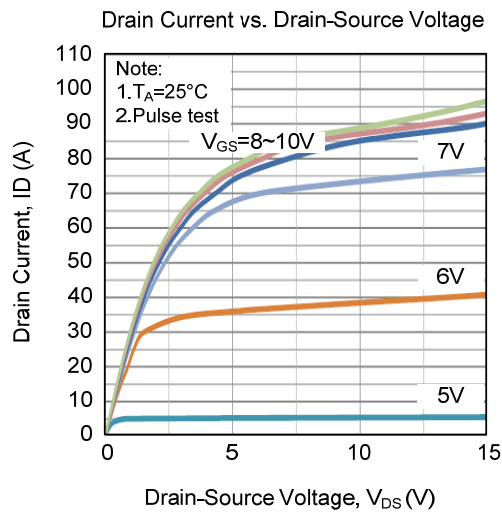
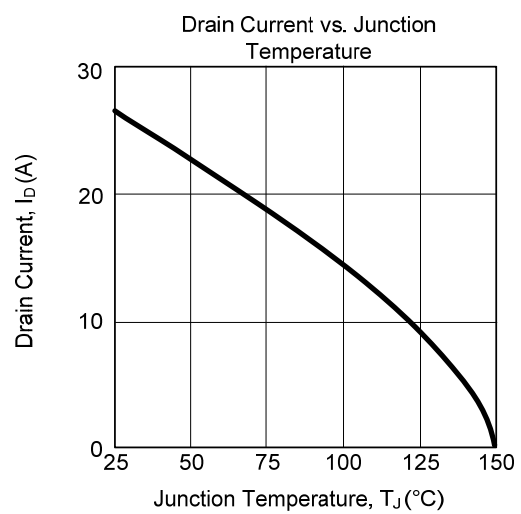
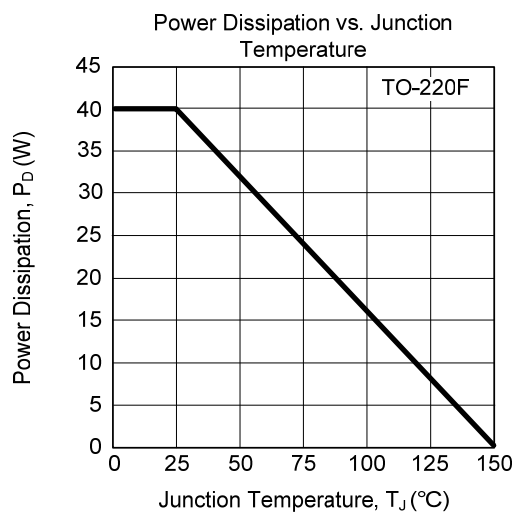
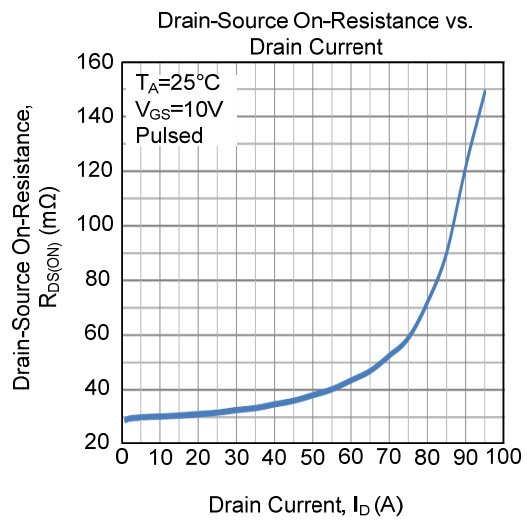
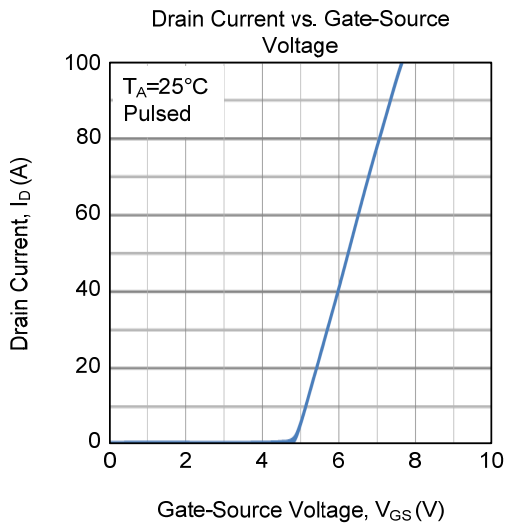
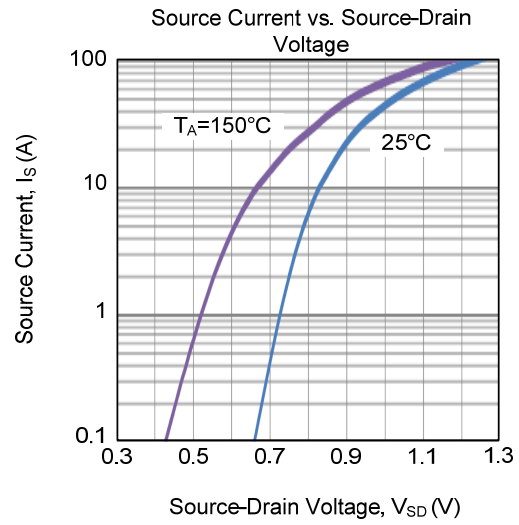
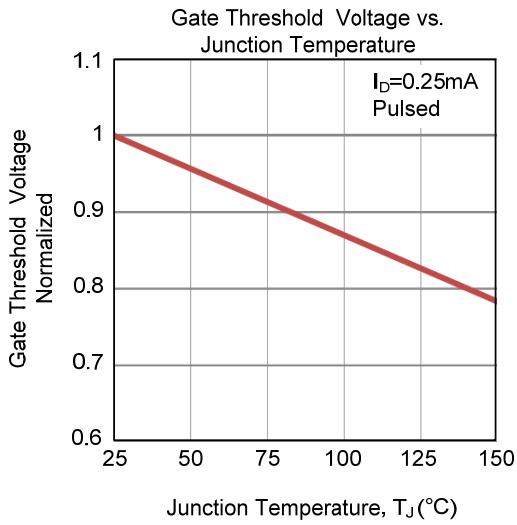

Fig.2 Switching Waveforms

TYPICAL CHARACTERISTICS



■ TYPICAL CHARACTERISTICS (Cont.)



■ TYPICAL CHARACTERISTICS (Cont.)

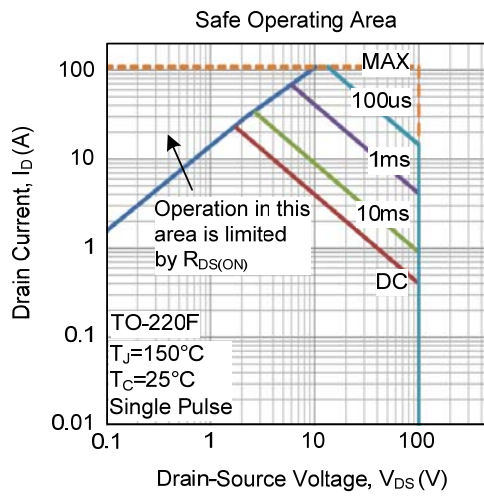

UTC assumes no responsibility for equipment failures that result from using products at values that exceed, even momentarily, rated values (such as maximum ratings, operating condition ranges, or other parameters) listed in products specifications of any and all UTC products described or contained herein. UTC products are not designed for use in life support appliances, devices or systems where malfunction of these products can be reasonably expected to result in personal injury. Reproduction in whole or in part is prohibited without the prior written consent of the copyright owner. UTC reserves the right to make changes to information published in this document, including without limitation specifications and product descriptions, at any time and without notice. This document supersedes and replaces all information supplied prior to the publication hereof.