

PRECISION BAROMETER AND ALTIMETER SENSOR

Key Features

- Operation temperature: -40~85°C
- Supply voltage: 1.7V to 3.6V
- Pressure range: 300mBar ~1200mBar
- Pressure temperature sensitivity: < 0.5Pa/K
- Pressure sensor precision: ± 0.005 hPa (or ± 5 cm)
- Average current consumption: @1Hz sampling rate, Standby: <0.5 μ A
- 8-pin LGA, 3.8 mm x 3.6mm x 1.2 mm
- Stores up to 32 pressure or temperature measurements
- I2C and SPI (both with optional interrupt)

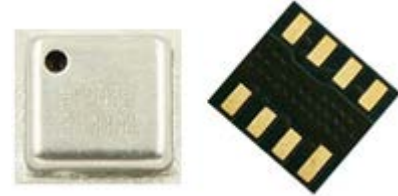

3.6x3.8x1.2mm

Applications

- Mobile Altimeter / Barometer
- Industrial Pressure and Temperature Sensor System
- Adventure and Sports watches
- Weather Station Equipment
- Indoor Navigation and Map Assist
- Data loggers for pressure, temperature and altitude
- Panel computer
- Barometers

Descriptions

The HP303F is a miniaturized Digital Barometric Air Pressure Sensor with a high accuracy and a low current consumption, capable of measuring both pressure and temperature. The pressure sensor element is based on a capacitive principle which guarantees high precision during temperature changes. The small package makes the HP303F ideal for mobile applications and wearable devices.

The HP303F result FIFO can store up to 32 measurement results, allowing for a reduced host processor polling rate. Sensor measurements and calibration coefficients are available through the serial I2C or SPI interface. The measurement status is indicated by status bits or interrupts on the SDO pin.

1. Pin Configuration

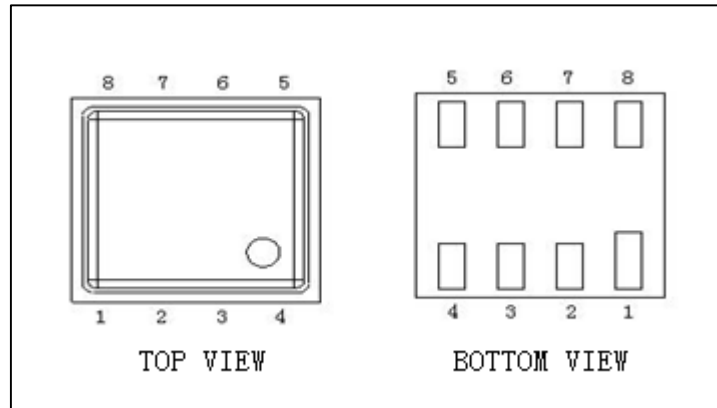

Table1 Pin Descriptions

Pin	Name	SPI 3-wire	SPI 3-wire with interrupt	SPI 4-wire	I2C	I2C with interrupt	
1	VDDIO	Digital supply voltage for digital blocks and I/O interface					
2	GND	Ground					
3	VDD	Supply voltage for analog blocks					
4	NC	No connect					
5	SCK	Serial Clock					
6	SDI	Serial data in/out	Serial data in/out	Serial data in	Serial data in/out	Serial data in/out	
7	CSB	Chip select - active low	Chip select - active low	Chip select - active low	Not used - open (internal pull-up) or tie to VDDIO	Not used - open (internal pull-up) or tie to VDDIO	
8	SDO	Not used	Interrupt	Serial data out	Least significant bit in the device address.	Interrupt pin and least significant bit in the device address.	

2. Typical Application Circuit

Figure3: Application Circuit Example using the I2C serial interface.

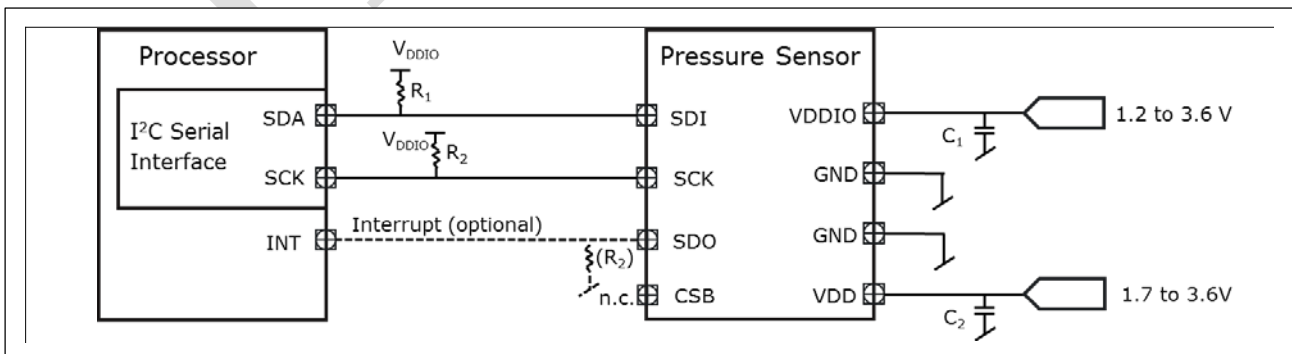

Figure4: Application Circuit Example using the SPI 4-wires serial interface

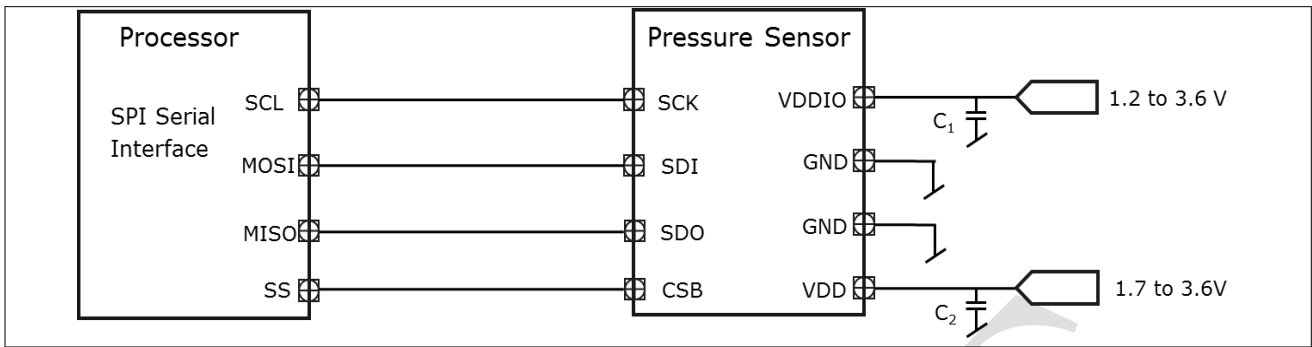

Figure5: Application Circuit Example using the SPI 3-wire serial interface

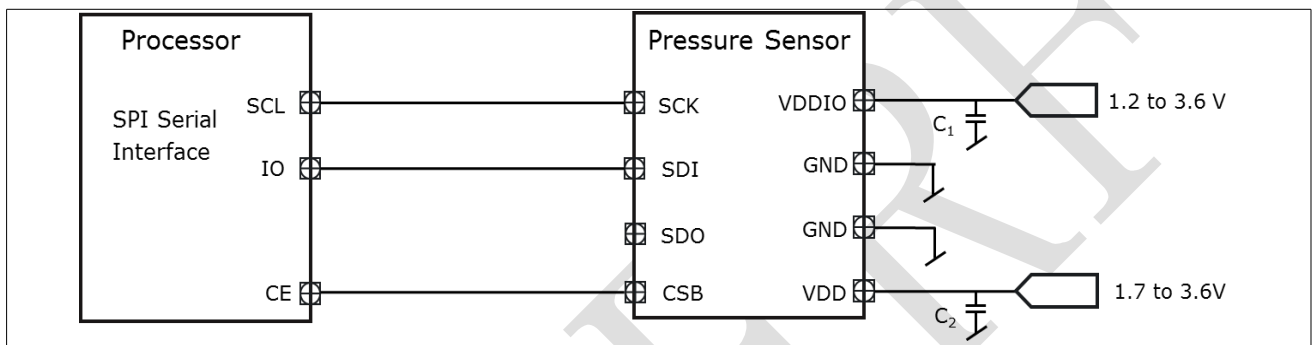

Figure6: Application Circuit Example using the SPI 3-wire with interrupt interface

Table2 Component Values

Component	Symbol	Values			Unit	Note / Test Condition
		Min.	Typ.	Max.		
Pull-up/down Resistor	R ₁ , R ₂	5		100	KΩ	R ₂ is optional and will set the address to 0x76 instead of 0x77.
Supply Blocking Capacitor	C ₁ , C ₂	100	100		nF	The blocking capacitors should be placed as close to the package pins as possible.

3. Mechanical and Electrical Specifications

3.1 Operating Range

Table 3 Operating Range

Parameter	Symbol	Values			Unit	Note / Test Condition
		Min.	Typ.	Max.		
Pressure	P_a	300		1200	hPa	
Temperature	T_a	-40		85	°C	
Supply voltage	V_{DD}	1.7		3.6	V	
Supply voltage IO	V_{DDIO}	1.2		3.6	V	
Supply voltage ramp-up time	t_{vddup}	0.001		5	ms	Time for supply voltage to reach 90% of final value.
Solder drift			-0.8		hPa	Minimum solder height 50um.
Long term stability				1	hPa	12 months

3.2 Absolute Maximum Ratings

Maximum ratings are absolute ratings. Exceeding any one of these values may cause irreversible damage to the integrated circuit.

Table 4 Absolute Maximum Ratings

Parameter	Symbol	Values			Unit	Note / Test Condition
		Min.	Typ.	Max.		
V_{DD} and V_{DDIO}	V_{DDxx_max}			4	V	
Voltage on any pin	V_{max}			4	V	
Storage temperature	T_s	-40		125	°C	
Pressure	P_{max}			10,000	hPa	
ESD	V_{ESD_HBM}	-2		2	KV	HBM (JESD22-A114)

3.3 Current Consumption

Test conditions (unless otherwise specified in the table): $V_{DD}=1.8V$ and $V_{DDIO}=1.8V$. Typ. values ($P_A=1000hPa$ and $T_A=25^{\circ}C$). Max./Min. values ($P_A=950-1050hPa$ and $T_A=0...+65^{\circ}C$).

Table 5 Current Consumption

Parameter	Symbol	Values			Unit	Note / Test Condition
		Min.	Typ.	Max.		
Peak Current Consumption	I_{peak}		345		μA	during Pressure measurement
			280		μA	during Temperature measurement
Standby Current Consumption	I_{stb}		<0.5		μA	
Current Consumption. (1 measurement per second.)	I_{1Hz}		2.1		μA	Low precision
			11			Standard precision
			38			High precision

Note: The current consumption depends on both pressure measurement precision and rate. Please refer to the [Pressure Configuration \(PRS_CFG\)](#) register description for an overview of the current consumption in different combinations of measurement precision and rate.

3.4 Temperature Transfer Function

Test conditions (unless otherwise specified in the table): $V_{DD}=1.8V$ and $V_{DDIO}=1.8V$. Typ. values ($P_A=1000hPa$ and $T_A=25^{\circ}C$). Max./Min. values ($P_A=950-1050hPa$ and $T_A=0...+65^{\circ}C$).

Table 6 Temperature Transfer Function

Parameter	Symbol	Values			Unit	Note / Test Condition
		Min.	Typ.	Max.		
Temperature accuracy	A_t		± 0.5		$^{\circ}C$	$T_A=20...+60^{\circ}C$
			± 1.5	± 2.5		$T_A=-40...+85^{\circ}C$
Temperature data resolution	A_{t_res}		0.01		$^{\circ}C$	
Temperature measurement rate	f	1		128	Hz	

3.5 Pressure Transfer Function

Test conditions (unless otherwise specified in the table): $V_{DD}=1.8V$ and $V_{DDIO}=1.8V$. Typ. values ($P_A=1000hPa$ and $T_A=25^{\circ}C$).

Table 7 Pressure Transfer Function

Parameter	Symbol	Values			Unit	Note / Test Condition
		Min.	Typ.	Max.		
Absolute pressure accuracy	A_{p_abs}		+/-0.2		hPa	$P_A=400-1100hPa$ $T_A=20...+60^{\circ}C$
			+/-1.0		hPa	$P_A=300-1200hPa$ $T_A=0...+70^{\circ}C$
			+/-2.0		hPa	$P_A=300-1200hPa$ $T_A=-40...85^{\circ}C$
Relative pressure accuracy	A_{p_rel}		+/-0.1		hPa	$P_A=400-1100hPa$ $T_A=20...+60^{\circ}C$
Pressure precision	A_{p_prc}		5.0		Pa_{RMS}	Low Power
			1.2			Standard
			0.5			High Precision

Note: Pressure precision is measured as the average standard deviation. Please refer to the [Pressure Configuration \(PRS_CFG\)](#) register description for all precision mode options.

Power supply rejection	A_{p_psr}			0.063	Pa_{RMS}	Measured with 217Hz square wave and broad band noise, 100mV _{pp}
Pressure temperature sensitivity of calibrated measurements	A_{p_tmp}			0.5	Pa/K	1000hPa, 25...+40°C.
Pressure data resolution	A_{p_res}			0.06	Pa_{RMS}	
Pressure measurement rate	f	1		128	Hz	
Pressure measurement time	t		5.2		ms	Low Power
			27.6			Standard
			105			High Precision

Note: The pressure measurement time (and thus the maximum rate) depends on the pressure measurement precision. Please refer to the [Pressure Configuration \(PRS_CFG\)](#) register description for an overview of the possible combinations of measurement precision and rate.

3.6 Timing Characteristics

Table 8 Timing Characteristics

Parameter	Symbol	Values			Unit	Note / Test Condition
		Min.	Typ.	Max.		

Start-up timing

Time to sensor ready	T _{Sensor_rdy}			12	ms	The SENSOR_RDY bit in the Measurement Configuration register will be set when the sensor is ready.
Time to coefficients are available.	T _{Coef_rdy}			40	ms	The COEF_RDY bit in the Measurement Configuration register will be set when the coefficients can be read out.

Note: Start-up timing is measured from VDD > 1.2V & VDDIO > 0.6V or Soft Reset.

I ² C Clock.	f _{I2C}			3.4	MHz	
SPI Clock	f _{SPI}			10	MHz	

4. Functional Description

4.1 Operating Modes

The HP303F supports 3 different modes of operation: Standby, Command, and Background mode.

- Standby Mode
 - Default mode after power on or reset. No measurements are performed.
 - All registers and compensation coefficients are accessible.
- Command Mode
 - One temperature or pressure measurement is performed according to the selected precision.
 - The sensor will return to Standby Mode when the measurement is finished, and the measurement result will be available in the data registers.
- Background Mode
 - Pressure and/or temperature measurements are performed continuously according to the selected measurement precision and rate. The temperature measurement is performed immediately after the pressure measurement.
 - The FIFO can be used to store 32 measurement results and minimize the number of times the sensor must be accessed to read out the results.

Note: Operation mode and measurement type are set in the [Sensor Operating Mode and Status \(MEAS_CFG\)](#) register.

4.2 Mode transition diagram

The mode transition diagram is shown below.

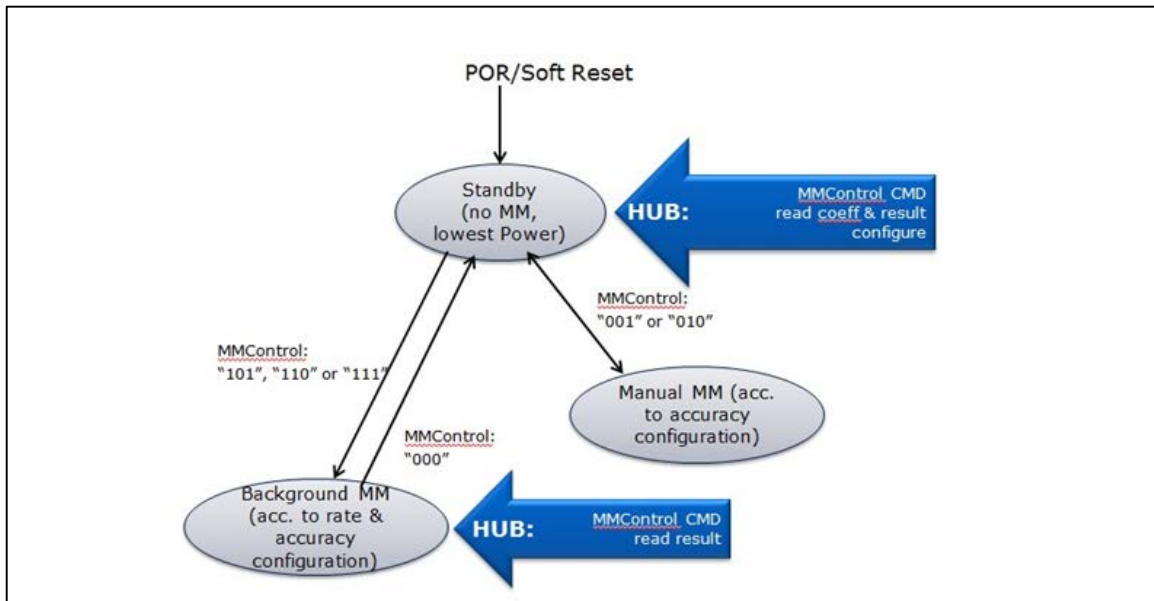

Figure7: Mode transition diagram

4.3 Start-up sequence

The star-up sequence of the HP303F is shown below. This diagram shows when the registers are accessible for read and/or write and also when the Pressure/Temperature measurements can start.

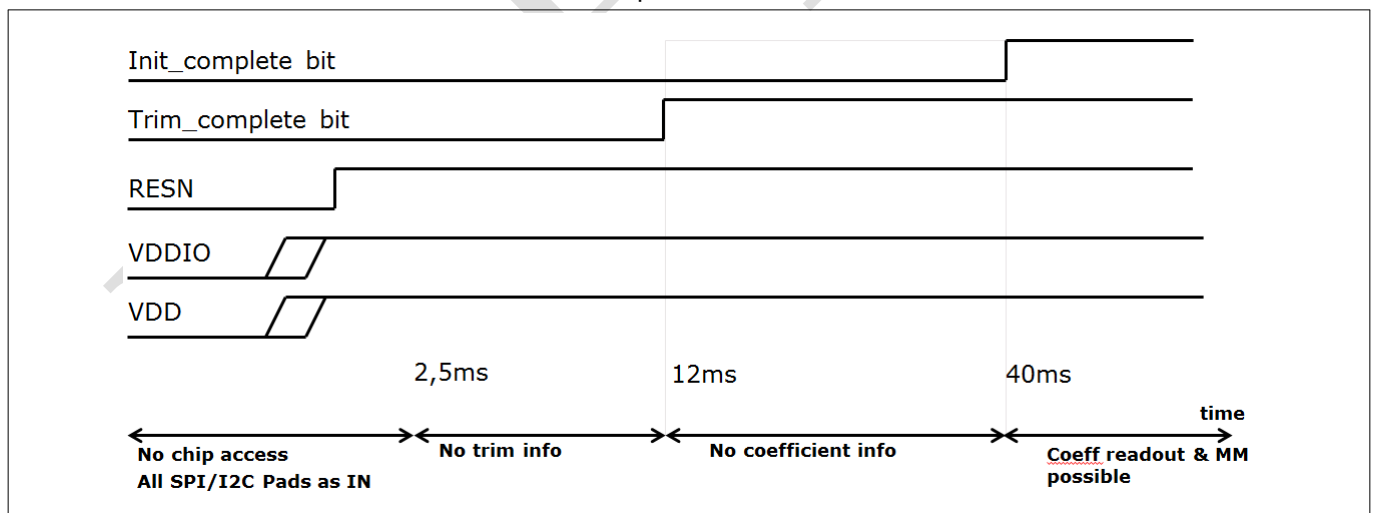

Figure 8: Start-up sequence

4.4 Measurement Precision and Rate

Different applications require different measurement precision and measurement rates. Some applications, such as weather stations, require lower precision and measurement rates than for instance indoor navigation and sports applications.

When the HP303F is in Background Mode, the measurement precision and rate can be configured to match the requirements of the application. This reduces current consumption of the sensor and the system.

In order to achieve a higher precision, the HP303F will read the sensor multiple times (oversampling), and combine the readings into one result. This increases the current consumption and also the measurement time, reducing the maximum possible measurement rate. It is necessary to balance the accuracy and data rate required for each application with the allowable current consumption.

The measurement precision, rate and time is set in the *Pressure Configuration (PRS_CFG)* and *Temperature Configuration (TMP_CFG)* registers. The register descriptions contain information about the current consumption and the possible combinations of measurement precision, time, and rate.

Enabling temperature measurements allows for compensation of temperature drift in the pressure measurement. The rates of these measurements can be set independently, but temperature compensation is more accurate when temperature and pressure measurements are taken together. This reduces the maximum pressure measurement rate, since: $Rate_{temperature} * Time_{temperature} + Rate_{pressure} * Time_{pressure} < 1 \text{ second}$.

Measurement Settings and Use Case Examples contains a table with examples of combinations of pressure and temperature precision and rates for different use cases.

In the figure below is described the Temperature and Pressure measurements sequence in background mode.

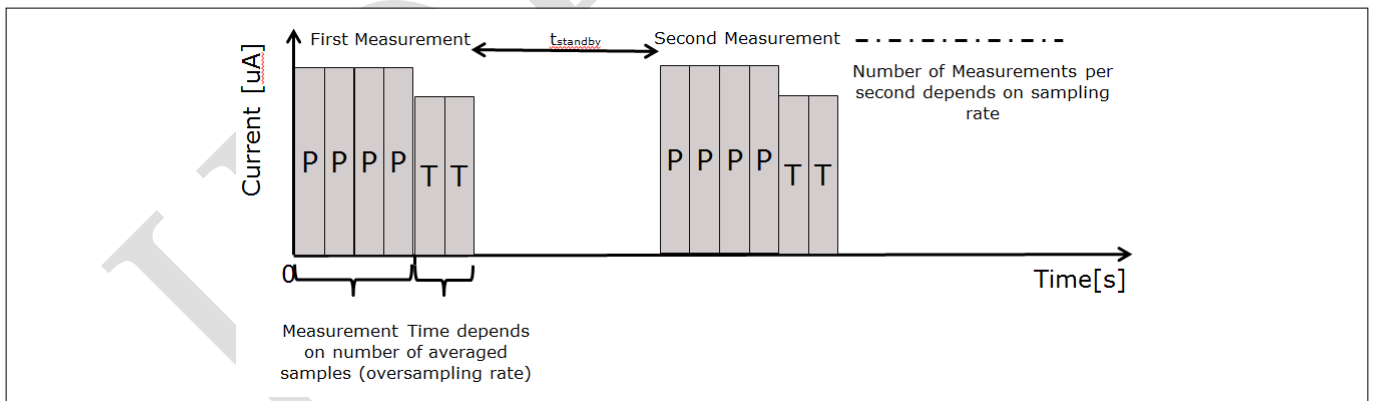

Figure 9: Background mode temperature and pressure measurements sequence

4.5 Sensor Interface

The HP303F can be accessed as a slave device through mode '11' SPI 3-wire, SPI 4-wire, or I²C serial interface.

- I²C interface
 - The sensor's default interface.
 - The sensor's address is 0x77 (default) or 0x76 (if the SDO pin is pulled-down to GND).
- SPI interface

- The sensor will switch to SPI configuration if it detects an active low on the CSB pin. SPI 4-wire is the default SPI interface.
- To enable SPI 3-wire configuration, a bit must be set in the *Interrupt and FIFO configuration (CFG_REG)* register after start up.

More details about digital interfaces are available in the *Digital interfaces*.

4.6 Interrupt

The HP303F can generate an interrupt when a new measurement result is available and/or when the FIFO is full. The sensor uses the SDO pin for the interrupt signal, and interrupt is therefore not supported if the interface is 4-wire SPI.

The interrupt is enabled and configured in the *Interrupt and FIFO configuration (CFG_REG)* register. In I2C configuration the SDO pin serves as both interrupt and as the least significant bit in the device address. If the SDO pin is pulled low the interrupt polarity must be set to active high and vice versa.

The interrupt status can be read from the *Interrupt Status (INT_STS)* register.

4.7 Result Register Operation

After starting the measurements, the latest pressure and temperature raw data will be available in their respective result registers. Temperature measurement can be skipped. The temperature measurements can be disabled if there is a requirement to measure pressure rapidly, but it will make accurate temperature drift compensation impossible.

All measurement data can be read in a single command using auto-increment read. When FIFO is disabled, reading the result register will not affect the register value, it will only be updated when a new measurement is completed. When FIFO is enabled, the pressure result register will update to the next value in the FIFO after each read. When all of the FIFO values have been read, the result register will be set to 0x800000.

4.8 FIFO Operation

The HP303F FIFO can store the last 32 measurements of pressure or temperature. This reduces the overall system power consumption as the host processor does not need to continuously poll data from the sensor but can go into standby mode for longer periods of time.

The FIFO can store any combination of pressure and temperature results, according to the background mode measurement rate settings. The pressure rate can for instance be set 4 times higher than the temperature rate and thus only every fifth result will be a temperature result. The measurement type can be seen in the result data. The sensor will set the least significant bit to:

- '1' if the result is a pressure measurement.
- '0' if it is a temperature measurement.
 - The sensor uses 24 bits to store the measurement result. Because this is more bits than is needed to cover the full dynamic range of the pressure sensor, using the least significant bit to label the measurement type will not affect the precision of the result.

The FIFO can be enabled in the Interrupt and FIFO configuration register. The data from the FIFO is read out from the Pressure Data (PRS_Bn) registers regardless of whether the next result in the FIFO is a temperature or a pressure measurement.

When a measurement has been read out, the FIFO will auto increment and place the next result in the data register. A flag will be set in the FIFO Status register when the FIFO is empty and all following reads will return 0x800000.

If the FIFO is full, the FIFO_FULL bit in the FIFO Status (FIFO_STS) will be set. If the INT_FIFO bit in the Interrupt and FIFO configuration register (CFG_REG) is set, an interrupt will also be generated when the FIFO is full.

The FIFO will stop recording measurements results when it is full.

4.9 Calibration and Measurement Compensation

The HP303F is a calibrated sensor and contains calibration coefficients. These are used in the application (for instance by the host processor) to compensate the measurement results for sensor non-linearities.

The sections that follow describe how to calculate the compensated results and convert them into Pa

4.9.1 How to Calculate Compensated Pressure Values

Step

1. Read the pressure calibration coefficients (c00, c10, c20, c30, c01, c11, and c21) from the Calibration coefficient register

Note: The coefficients read from the coefficient register are 16 bit 2's complement numbers.

2. Choose scaling factors kT (for temperature) and kP (for pressure) based on the chosen precision rate. The scaling factors are listed in [Table 9](#).

3. Read the pressure and temperature result from the registers or FIFO.

Note: The measurements read from the result registers (or FIFO) are 24 bit 2's complement numbers.

Depending on the chosen measurement rates, the temperature may not have been measured since the last pressure measurement.

4. Calculate scaled measurement results.

$$T_{raw_sc} = T_{raw} / kT$$

$$P_{raw_sc} = P_{raw} / kP$$

5. Calculate compensated measurement results.

$$P_{comp}(Pa) = c00 + P_{raw_sc} * (c10 + P_{raw_sc} * (c20 + P_{raw_sc} * c30)) + T_{raw_sc} * c01 + T_{raw_sc} * P_{raw_sc} * (c11 + P_{raw_sc} * c21)$$

4.9.2 How to Calculate Compensated Temperature Values

Steps

1. Read the temperature calibration coefficients (c0 and c1) from the [Calibration Coefficients \(COEF\)](#) register.

Note: The coefficients read from the coefficient register are 12 bit 2's complement numbers.

2. Choose scaling factor kT (for temperature) based on the chosen precision rate. The scaling factors are listed in [Table 9](#).

3. Read the temperature result from the temperature register or FIFO.

Note: The temperature measurements read from the temperature result register (or FIFO) are 24 bit 2's complement numbers.

4. Calculate scaled measurement results.

$$T_{raw_sc} = T_{raw} / kT$$

5. Calculate compensated measurement results.

$$T_{comp} (°C) = c0 * 0.5 + c1 * T_{raw_sc}$$

4.9.3 Compensation Scale Factors

Table 9 Compensation Scale Factors

Oversampling Rate	Scale Factor (kP or kT)
1 (single)	524288
2 times (Low Power)	1572864
4 times	3670016
8 times	7864320
16 times (Standard)	253952
32 times	516096
64 times (High Precision)	1040384
128 times	2088960

4.9.4 Pressure and Temperature calculation flow

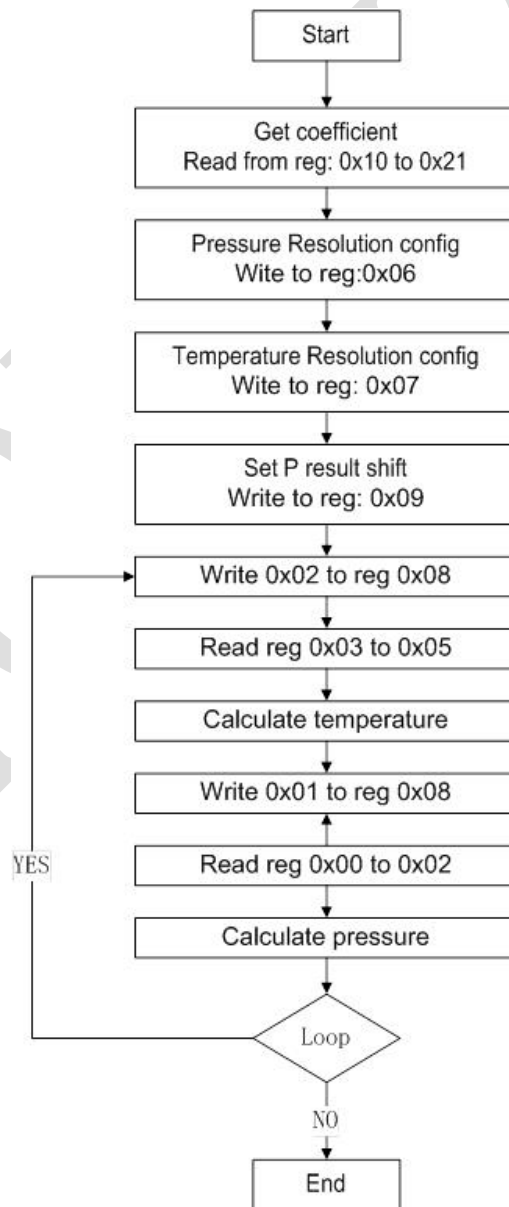

Figure 10: flow chart

5. Digital interfaces

The HP303F measurement data, calibration coefficients, Product ID and configuration registers can be accessed through both the I²C and SPI serial interfaces.

The SPI interface can be configured to operate in 3-wire or 4-wire mode. In I²C and SPI 3-wire, an interrupt output can be implemented on the SDO pin. The SPI interface supports mode '11' only (CPOL=CPHA='1') in 4-wire and 3-wire configuration. The following commands are supported: single byte write, single byte read and multiple byte read using auto-increment from a specified start address. The interface selection is done based on CSB pin status. If CSB is connected to V_{DDIO}, the I²C interface is active. If CSB is low, the SPI interface is active. After the CSB has been pulled down once the I²C interface is disabled until the next power-on-reset.

5.1 I²C Interface

The I²C slave interface is compatible with Philips I²C Specification version 2.1. The I²C interface supports standard, fast and high speed mode.

The sensor's address is 0x77 (if SDO pin is left floating or pulled-up to V_{DDIO}) or 0x76 (if the SDO pin is pulled-down to GND). The I²C interface uses the pins described in [Table 1](#)

The basic timing is shown in the diagram below:

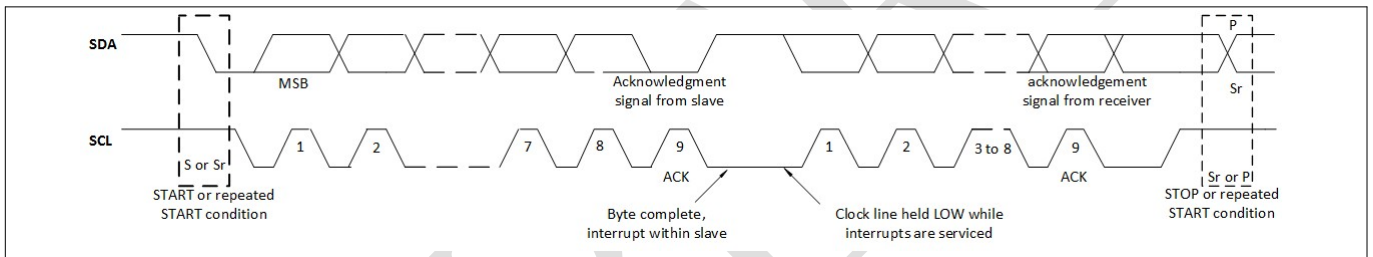

Figure 11 I²C timing diagram

In one access, without stop, incremental read (address is auto-increment) and auto-incremental write is supported. The read and write access is described below:

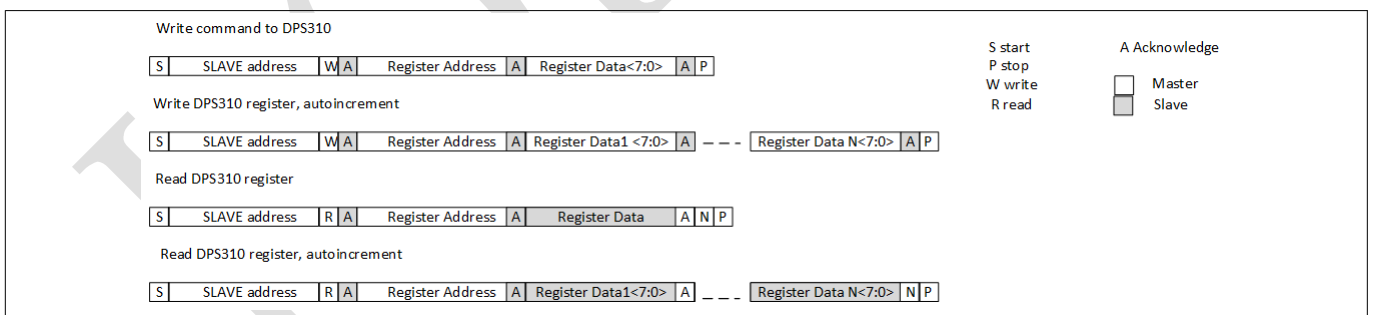

Figure 12 I²C write and read commands

5.2 SPI Interface

The SPI interface is compatible with SPI mode '11' (CPOL = CPHA = '1'). The SPI interface has two modes: 4-wire and 3-wire.

The protocol is the same for both. The 3-wire mode is selected by setting '1' to the register [Interrupt and FIFO configuration \(CFG_REG\)](#)

The SPI interface uses the pins like in the [Table 1](#). Refer to [Application Circuit Example](#) for connection instructions. The SPI protocol is shown in the diagram below

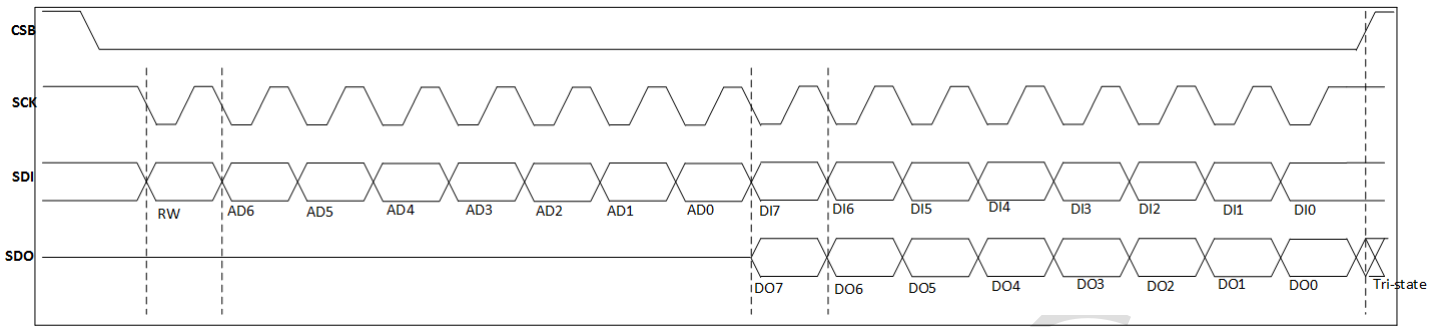
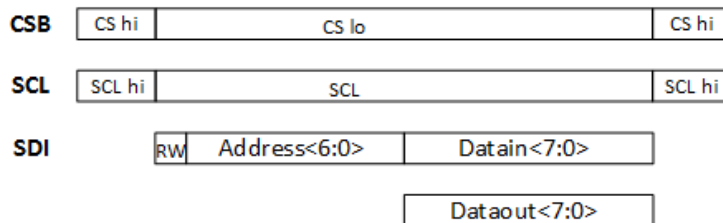

Figure 13 SPI protocol, 4-wire without interrupt

A SPI write is carried out by setting CSB low and sending a control byte followed by register data. The control byte consist of the SPI register address (full register address without bit 7) and the write command (bit7 = RW = '0'). Setting CSB high ends the transaction. The SPI write protocol is described in the diagram below.

A SPI read is initiated by setting CSB low and sending a single control byte. The control byte consist of the SPI register address (= full register address without bit 7) and the read command (bit7 = RW = '1'). After writing the control byte, data is sent out of the SDO pin (SDI in 3-wire mode); the register address is automatically incremented. Sending CSB high ends the SPI read transaction. The SPI read protocol is shown in the diagram below:

Single byte W/R in 4 wire SPI:



Single byte W/R in 3 wire SPI:

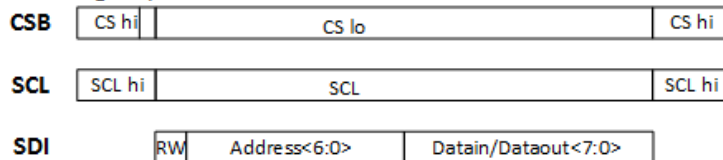

Multi byte R in 3 wire SPI

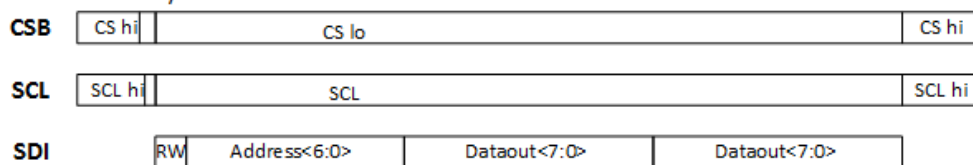

Multi byte R in 4 wire SPI

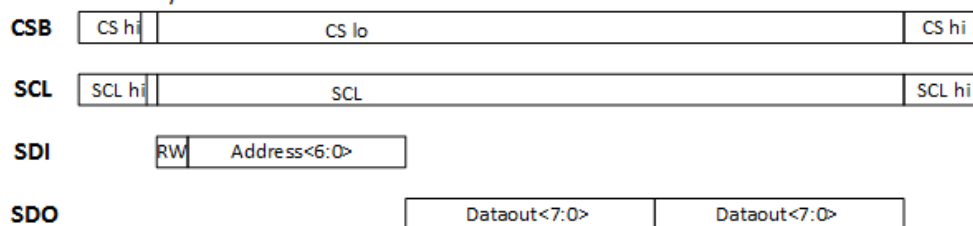

Figure 14 SPI write, read protocol diagrams

5.3 Interface parameters specification

The general interface parameters are given in the table below:

Table 12 Interface parameters

Parameter	Symbol	Values			Unit	Note or Test Condition
		Min.	Typ.	Max.		
Input voltage for low logic level at input pins	Vlow_in			0.3 * V _{DDIO}	V	V _{DDIO} =1.2V to 3.6V
Input voltage for high logic level at input pins	Vhigh_in	0.7 * V _{DDIO}			V	V _{DDIO} =1.2V to 3.6V
Output - low level for I2C	Vlow_SDI			0.1 * V _{DDIO}	V	V _{DDIO} =1.8V, iol=2mA
Output voltage for low level at pin SDI for I2C	Vlow_SDI_1.2			0.2* V _{DDIO}	V	V _{DDIO} =1.20V, iol=1.3mA
Output voltage for high level at pins SDO, SDI	Vhigh_out	0.8 * V _{DDIO}			V	V _{DDIO} =1.8V, iol=1mA (SDO, SDI)
Output voltage for high level at pins SDO, SDI	Vhigh_out_1.2	0.6 * V _{DDIO}			V	V _{DDIO} =1.2V, iol=1mA (SDO, SDI)
Pull-up resistor	Rpull	60	120	180	kohm	Internal pull-up resistance to VDDIO
I2C bus load capacitor	Cb			400	pF	On SDI and SCK

5.3.1 I2C timings

The I²C timing is shown in the diagram below and corresponding values are given in the table below. The naming refers to I²C Specification version 2.1, the abbreviations used "S&F mode" = standard and fast mode, "HS mode" = high speed mode, C_b = bus capacitance on SDA line.

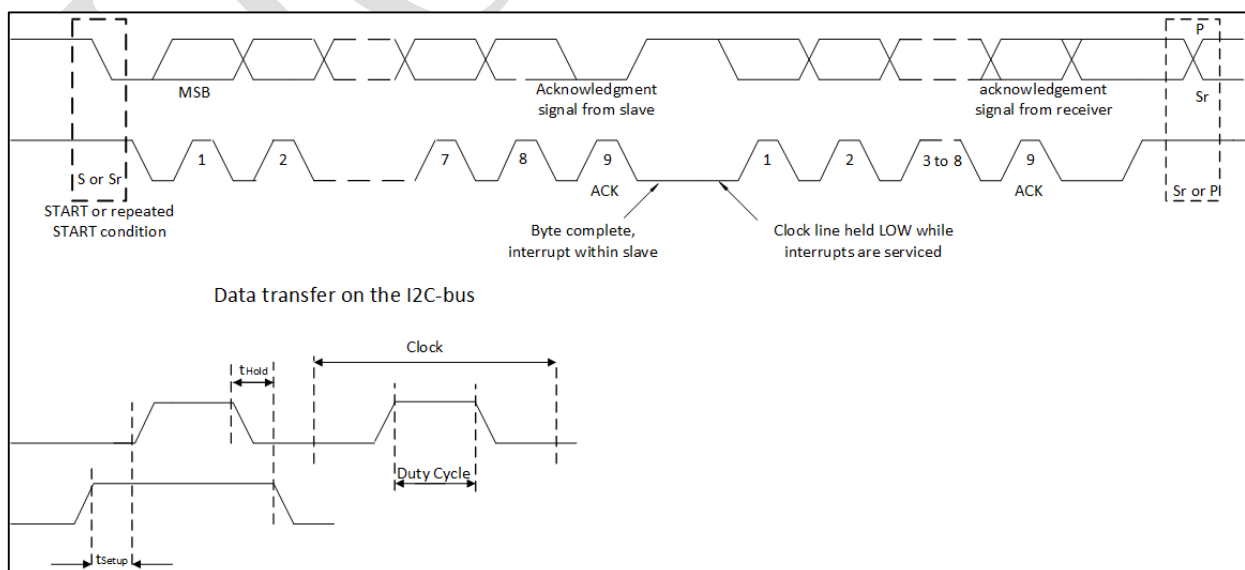

Figure 15 I2C timing diagram

Table 13 I2C timings

Parameter	Symbol	Values			Unit	Note or Test Condition
		Min.	Typ.	Max.		
Data setup time on SDI pin	t_{Setup}	20			ns	S&F mode
		5			ns	HS mode
Data hold time on SDI pin	t_{Hold}	0			ns	S&F&HSmode,
Duty Cycle	DC			70	%	S&F mode,
				55	%	HS mode,

5.3.2 SPI timings

The SPI timing diagram is shown in the figure below and the corresponding values are given in the table below. All timings apply to both to 4-wire and 3-wire SPI.

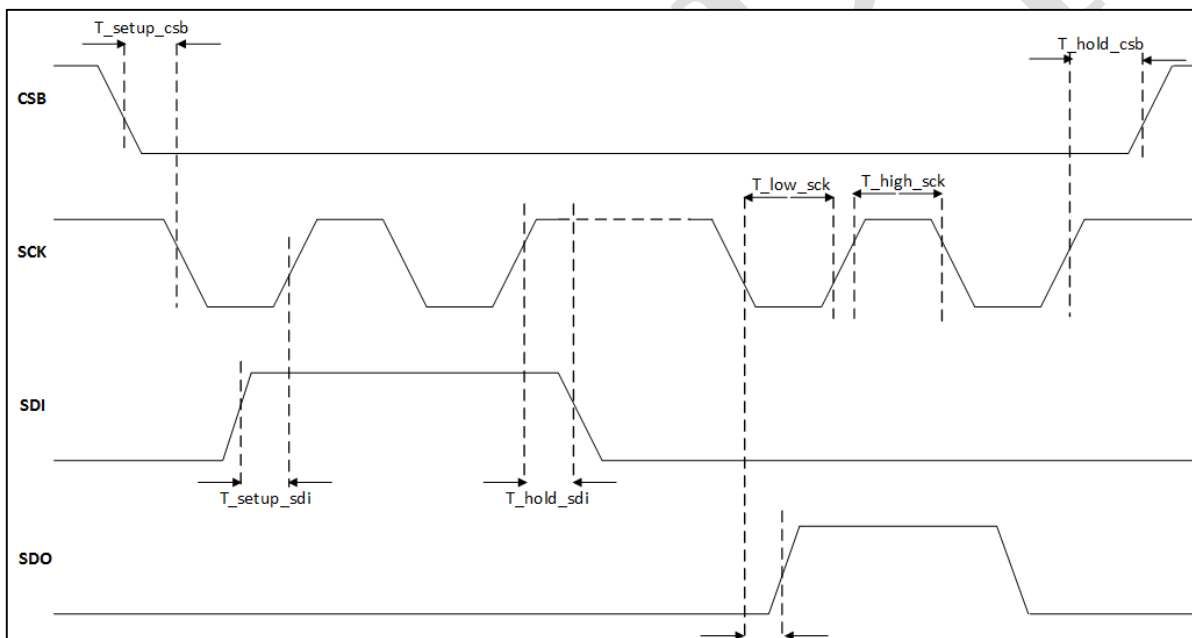

Figure 16 SPI timing diagram

Table 14 SPI timings

Parameter	Symbol	Values			Unit	Note or Test Condition
		Min.	Typ.	Max.		
Duty Cycle (Thigh%)	SPI_DC	30			%	$V_{DDIO} = 1.2V$
		20			%	$V_{DDIO} = 1.8V/3.6V$
SDI setup time	T_{setup_sdi}	2			ns	
SDI hold time	T_{hold_sdi}	2			ns	
Clock	SPI_CLK			10	MHz	
CSB setup time	T_{setup_csb}	15			ns	
CSB hold time		15			ns	

6. Register Map

Table 15 Register Map

Register Name	Addr.	bit7	bit6	bit5	bit4	bit3	bit2	bit1	bit0	Reset State
PSR_B2	0x00	PSR[23:16] (r)								00h
PSR_B1	0x01	PSR[15:8](r)								00h
PSR_B0	0x02	PSR[7:0](r)								00h
TMP_B2	0x03	TMP[23:16] (r)								00h
TMP_B1	0x04	TMP[15:8] (r)								00h
TMP_B0	0x05	TMP[7:0] (r)								00h
PRS_CFG	0x06	-	PM_RATE [2:0] (rw)			PM_PRC [3:0] (rw)				00h
TMP_CFG	0x07	TMP_EXT (rw)	TMP_RATE [2:0] (rw)			TM_PRC [3:0] (rw)				00h
MEAS_CFG	0x08	COEF_RDY (r)	SENSOR_RDY (r)	TMP_RDY (r)	PRS_RDY (r)	-	MEAS_CRTL [2:0] (rw)			00h
CFG_REG	0x09	INT_HL (rw)	INT_SEL [2:0] (rw)			TMP_SHIFT_EN (rw)	PRS_SHIFT_EN (rw)	FIFO_EN (rw)	SPI_MODE (rw)	00h
INT_STS	0x0A	-	-	-	-	-	INT_FIFO_FULL (r)	INT_TMP(r)	INT_PRS(r)	00h
FIFO_STS	0x0B	-	-	-	-	-	-	FIFO_FULL(r)	FIFO_EMPTY(r)	00h
RESET	0x0C	FIFO_FLUSH (w)	-	-	-	SOFT_RST [3:0] (w)			00h	
Product ID	0x0D	REV_ID [3:0] (r)				PROD_ID [3:0] (r)				10h
COEF	0x10-0x21	< see register description >								XXh
Reserved	0x22-0x27	Reserved								XXh
COEF_SRCE	0x28	TMP_COEF_SRCE (r)	Reserved							XXh

7. Register description

7.1 Pressure Data (PRS_Bn)

The Pressure Data registers contains the 24 bit (3 bytes) 2's complement pressure measurement value. If the FIFO is enabled, the register will contain the FIFO pressure and/or temperature results (please see [FIFO operation](#)). Otherwise, the register contains the pressure measurement results and will not be cleared after read.

7.1.1 PRS_B2

The highest byte of the three bytes measured pressure value.

PRS_B2 Address: 00H
 Pressure (MSB data) Reset value: 00H

7	6	5	4	3	2	1	0
PRS23	PRS22	PRS21	PRS20	PRS19	PRS18	PRS17	PRS16

Field	Bits	Type	Description
PRS[23:16]	7:0	r	MSB of 24 bit 2's complement pressure data.

7.1.2 PRS_B1

The middle byte of the three bytes measured pressure value.

PRS_B1 Address: 01H
 Pressure (LSB data) Reset value: 00H

7	6	5	4	3	2	1	0
PRS15	PRS14	PRS13	PRS12	PRS11	PRS10	PRS9	PRS8-

Field	Bits	Type	Description
PRS[15:8]	7:0	r	LSB of 24 bit 2's complement pressure data.

7.1.3 PRS_B0

The lowest byte of the three bytes measured pressure value.

PRS_B0 Address: 02H
 Pressure (XLSB data) Reset value: 00H

7	6	5	4	3	2	1	0
PRS7	PRS6	PRS5	PRS4	PRS3	PRS2	PRS1	PRS0

r

Field	Bits	Type	Description
PRS[7:0]	7:0	r	XLSB of 24 bit 2's complement pressure data.

7.2 Temperature Data (TMP_Tn)

The Temperature Data registers contain the 24 bit (3 bytes) 2's complement temperature measurement value (Unless the FIFO is enabled, please see FIFO operation) and will not be cleared after the read.

7.2.1 TMP_B2

The highest byte of the three bytes measured temperature value.

TMP_B2 Address: 03H
 Temperature (MSB data) Reset value: 00H

7	6	5	4	3	2	1	0
TMP23	TMP22	TMP21	TMP20	TMP19	TMP18	TMP17	TMP16

r

Field	Bits	Type	Description
TMP[23:16]	7:0	r	MSB of 24 bit 2's complement temperature data.

7.2.2 TMP_B1

The middle byte of the three bytes measured temperature value.

TMP_B1 Address: 04H
 Temperature (LSB data) Reset value: 00H

7	6	5	4	3	2	1	0
TMP15	TMP14	TMP13	TMP12	TMP11	TMP10	TMP9	TMP8

r

Field	Bits	Type	Description
TMP[15:8]	7:0	r	LSB of 24 bit 2's complement temperature data.

7.2.3 TMP_B0

The lowest part of the three bytes measured temperature value.

TMP_B0 Address: 05H
 Temperature (XLSB data) Reset value: 00H

7	6	5	4	3	2	1	0
TMP7	TMP6	TMP5	TMP4	TMP3	TMP2	TMP1	TMP0

r

Field	Bits	Type	Description
TMP[7:0]	7:0	r	XLSB of 24 bit 2's complement temperature data.

7.3 Pressure Configuration (PRS_CFG)

Configuration of pressure measurement rate (PM_RATE) and resolution (PM_PRC)

PRS_CFG **Address:** 06_H
 Pressure measurement configuration **Reset value:** 00_H

7 6 5 4 3 2 1 0

-	PM_RATE[2:0]	PM_PRC[3:0]
---	---------------------	--------------------

- rw rw

Field	Bits	Type	Description
-	7	-	Reserved.
PM_RATE[2:0]	6:4	rw	Pressure measurement rate: 000 - 1 measurements pr. sec. 001 - 2 measurements pr. sec. 010 - 4 measurements pr. sec. 011 - 8 measurements pr. sec. 100 - 16 measurements pr. sec. 101 - 32 measurements pr. sec. 110 - 64 measurements pr. sec. 111 - 128 measurements pr. sec. <i>Applicable for measurements in Background mode only</i>
PM_PRC[3:0]	3:0	rw	Pressure oversampling rate: 0000 - Single. (Low Precision) 0001 - 2 times (Low Power). 0010 - 4 times. 0011 - 8 times. 0100 *) - 16 times (Standard). 0101 *) - 32 times. 0110 *) - 64 times (High Precision). 0111 *) - 128 times. 1xxx - TBD

*Note: Use in combination with a bit shift. See [Interrupt and FIFO configuration \(CFG_REG\)](#) register

Table 16 Pressure measurement time (ms) and precision (Pa_{RMS})

Oversampling (PRC[3:0])	Single (0000)	2 times (0001)	4 times (0010)	8 times (0011)	16 times (0100)	32 times (0101)	64 times (0110)	128 times (0111)
Measurement time (ms)	3.6	5.2	8.4	14.8	27.6	53.2	104.4	206.8
Precision (Pa _{RMS})	5		2.5		1.2	0.9	0.5	

Table 17 Estimated current consumption (uA)

Oversampling (PRC[3:0]) Measurements pr sec. (PM_RATE([2:0]))	Single (0000)	2 times (0001)	4 times (0010)	8 times (0011)	16 times (0100)	32 times (0101)	64 times (0110)	128 times (0111)
1 (000)	2.1	2.7	3.8	6.1	11	20	38	75
2 (001)								
4 (010)								
8 (011)	<i>Note: The current consumption can be calculated as the Measurement Rate * Current Consumption of 1 measurement per. sec.</i>							n.a.
16 (100)							n.a.	n.a.
32 (101)						n.a.	n.a.	n.a.
64 (110)					n.a.	n.a.	n.a.	n.a.
128 (111)			n.a.	n.a.	n.a.	n.a.	n.a.	n.a.

Note: The table shows the possible combinations of Pressure Measurement Rate and oversampling when no temperature measurements are performed. When temperature measurements are performed the possible combinations are limited to $Rate_{temperature} \times Measurement\ Time_{temperature} + Rate_{pressure} \times Measurement\ Time_{pressure} < 1\ second$.

7.4 Temperature Configuration (TMP_CFG)

Configuration of temperature measurement rate (TMP_RATE) and resolution (TMP_PRC)

TMP_CFG Address: 07_H
 Temperature measurement configuration Reset value: 00_H

	7	6	5	4	3	2	1	0
TMP_EXT	TMP_RATE[6:4]			-	TMP_PRC[2:0]			
rw	rw			-	rw			

Field	Bits	Type	Description
TMP_EXT	7	rw	Temperature measurement 0 - Internal sensor (TBD) 1 - External sensor (in pressure sensor MEMS element) <i>Note: It is highly recommended to use the same temperature sensor as the source of the calibration coefficients. Please see the Coefficient Source register</i>
TMP_RATE[2:0]	6:4	rw	Temperature measurement rate: 000 - 1 measurement pr. sec. 001 - 2 measurements pr. sec. 010 - 4 measurements pr. sec. 011 - 8 measurements pr. sec. 100 - 16 measurements pr. sec. 101 - 32 measurements pr. sec. 110 - 64 measurements pr. sec. 111 - 128 measurements pr. sec.. <i>Applicable for measurements in Background mode only</i>
TMP_PRC[2:0]	2:0	rw	Temperature oversampling (precision): 000 - single. (Default) - Measurement time 3.6 ms. <i>Note: Following are optional, and may not be relevant:</i> 001 - 2 times. 010 - 4 times. 011 - 8 times. 100 - 16 times. 101 - 32 times. 110 - 64 times. 111 - 128 times. 1xxx - TBD.

7.5 Sensor Operating Mode and Status (MEAS_CFG)

Setup measurement mode

MEAS_CFG **Address:** 08H
 Measurement configuration **Reset value:** 00H

7	6	5	4	3	2	1	0
COEF_RDY	SENSOR_RDY	TEM_RDY	PRS_RDY	-	MEAS_CTRL		
r	r	r	r	-	rw		

Field	Bits	Type	Description
COEF_RDY	7	r	Coefficients will be read to the Coefficients Registers after start-up: 0 - Coefficients are not available yet. 1 - Coefficients are available.
SENSOR_RDY	6	r	The pressure sensor is running through self-initialization after start-up. 0 - Sensor initialization not complete 1 - Sensor initialization complete It is recommended not to start measurements until the sensor has completed the self-initialization.
TMP_RDY	5	r	Temperature measurement ready 1 - New temperature measurement is ready. Cleared when temperature measurement is read.
PRS_RDY	4	r	Pressure measurement ready 1 - New pressure measurement is ready. Cleared when pressure measurement is read.
-	3	-	Reserved.
MEAS_CTRL	2:0	rw	Set measurement mode and type: <i>Standby Mode</i> 000 - Idle / Stop background measurement <i>Command Mode</i> 001 - Pressure measurement 010 - Temperature measurement 011 - na. 100 - na. <i>Background Mode</i> 101 - Continuous pressure measurement 110 - Continuous temperature measurement 111 - Continuous pressure and temperature measurement

7.6 FIFO configuration (CFG_REG)

Configuration of interrupts, measurement data shift, and FIFO enable.

CFG_REG **Address:** 09H
Configuration register **Reset value:** 00H

7	6	5	4	3	2	1	0
—				T_SHIFT	P_SHIFT	FIFO_EN	—
—				rw	rw	rw	—

Field	Bits	Type	Description
INT_HL	7	rw	Interrupt (on SDO pin) active level: 0 - Active low. 1 - Active high.
INT_FIFO	6	rw	Generate interrupt when the FIFO is full: 0 - Disable. 1 - Enable.
INT_TMP	5	rw	Generate interrupt when a temperature measurement is ready: 0 - Disable. 1 - Enable.
INT_PRS	4	rw	Generate interrupt when a pressure measurement is ready: 0 - Disable. 1 - Enable.
T_SHIFT	3	rw	Temperature result bit-shift 0 - no shift. 1 - shift result right in data register. <i>Note: Must be set to '1' when the oversampling rate is >8 times.</i>
P_SHIFT	2	rw	Pressure result bit-shift 0 - no shift. 1 - shift result right in data register. <i>Note: Must be set to '1' when the oversampling rate is >8 times.</i>
FIFO_EN	1	rw	Enable the FIFO: 0 - Disable. 1 - Enable.
SPI_MODE	0	rw	Set SPI mode: 0 - 4-wire interface. 1 - 3-wire interface.

7.8 Soft Reset and FIFO flush (RESET)

Flush FIFO or generate soft reset.

RESET Address: 0CH
 FIFO flush and soft reset Reset value: 00H

7 6 5 4 3 2 1 0

FIFO_FLUSH	-					SOFT_RST	
------------	---	--	--	--	--	----------	--

w - w

Field	Bits	Type	Description
FIFO_FLUSH	7	w	FIFO flush 1 - Empty FIFO After reading out all data from the FIFO, write '1' to clear all old data.
-	6:4	-	Reserved.
SOFT_RST	3:0	w	Write '1001' to generate a soft reset. A soft reset will run through the same sequences as in power-on reset.

7.9 Product and Revision ID (ID)

Product and Revision ID

ID Address: 0DH
 Product and revision ID Reset value: 0x10H

7 6 5 4 3 2 1 0

	REV_ID					PROD_ID	
--	--------	--	--	--	--	---------	--

r r

Field	Bits	Type	Description
REV_ID	7:4	r	Revision ID
PROD_ID	3:0	r	Product ID

7.10 Calibration Coefficients (COEF)

The Calibration Coefficients register contains the 2's complement coefficients that are used to calculate the compensated pressure and temperature values.

Table 17 Calibration Coefficients

Coefficient	Addr.	bit7	bit6	bit5	bit4	bit3	bit2	bit1	bit0
c0	0x10	c0 [11:4]							
c0/c1	0x11	c0 [3:0]				c1 [11:8]			
c1	0x12	c1[7:0]							
c00	0x13	c00 [19:12]							
c00	0x14	c00 [11:4]							
c00/c10	0x15	c00 [3:0]				c10 [19:16]			
c10	0x16	c10 [15:8]							
c10	0x17	c10 [7:0]							
c01	0x18	c01 [15:8]							
c01	0x19	c01 [7:0]							
c11	0x1A	c11 [15:8]							
c11	0x1B	c11 [7:0]							
c20	0x1C	c20 [15:8]							
c20	0x1D	c20 [7:0]							
c21	0x1E	c21 [15:8]							
c21	0x1F	c21 [7:0]							
c30	0x20	c30 [15:8]							
c30	0x21	c30 [7:0]							

Note: Generate the decimal numbers out of the calibration coefficients registers data:

$C20 := \text{reg0x1D} + \text{reg0x1C} * 2^8$

if ($C20 > (2^{15} - 1)$)

$C20 := C20 - 2^{16}$

end if

$C0 := (\text{reg0x10} * 2^4) + ((\text{reg0x11} / 2^4) \& 0x0F)$

if ($C0 > (2^{11} - 1)$)

$C0 := C0 - 2^{12}$

end if

9. Package dimensions

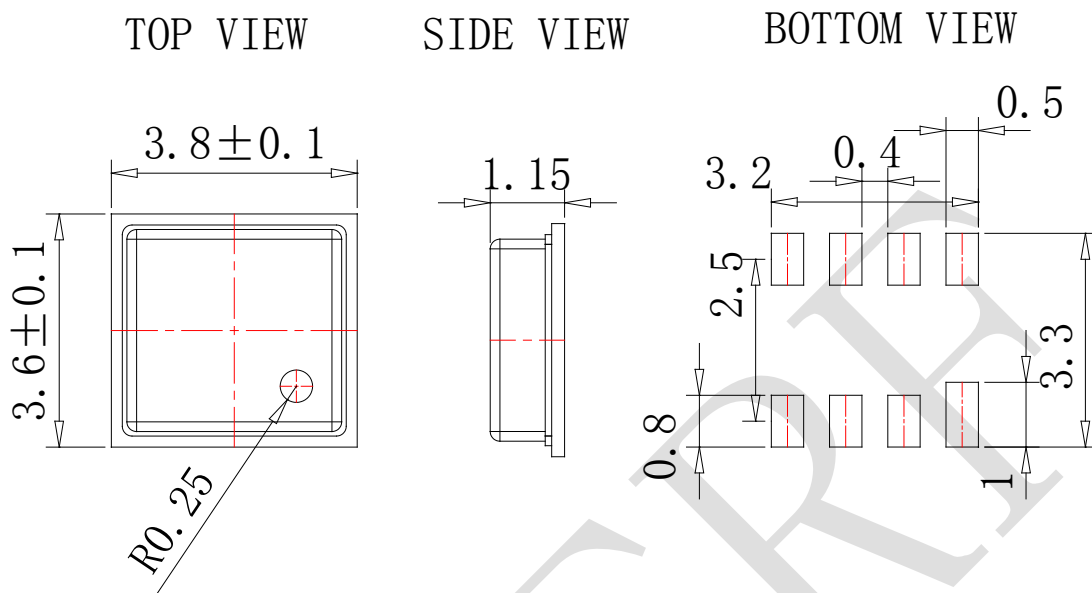

Notes:

- (1) Mechanical Dimension (unit: mm)
- (2) General tolerance (0.10mm)

HOPE MICROELECTRONICS CO., LTD

Add: 2/F, Building 3, Pingshan Private Enterprise Science and Technology Park, Lishan Road, XiLi Town, Nanshan District, Shenzhen, Guangdong, China

Tel: +86 755 82973805

Fax: +86 755 82973550

Email: sales@hoperf.com

Website: <http://www.hoperf.com>
<http://www.hoperf.cn>

This document may contain preliminary information and is subject to change by Hope Microelectronics without notice. Hope Microelectronics assumes no responsibility or liability for any use of the information contained herein. Nothing in this document shall operate as an express or implied license or indemnity under the intellectual property rights of Hope Microelectronics or third parties. The products described in this document are not intended for use in implantation or other direct life support applications where malfunction may result in the direct physical harm or injury to persons. NO WARRANTIES OF ANY KIND, INCLUDING, BUT NOT LIMITED TO, THE IMPLIED WARRANTIES OF MECHANICAL FITNESS OR FITNESS FOR A PARTICULAR PURPOSE, ARE OFFERED IN THIS DOCUMENT.

©2018, HOPE MICROELECTRONICS CO.,LTD. All rights reserved.
 Rev:HP303F datasheet V1.0