

ARM® ARM926EL-S Based 32-bit Microprocessor

RDK-N9H20 Demo Board User Manual

The information described in this document is the exclusive intellectual property of Nuvoton Technology Corporation and shall not be reproduced without permission from Nuvoton.

Nuvoton is providing this document only for reference purposes of NuMicro microcontroller based system design. Nuvoton assumes no responsibility for errors or omissions.

All data and specifications are subject to change without notice.

For additional information or questions, please contact: Nuvoton Technology Corporation.

www.nuvoton.com

Table of Contents

1 OVERVIEW 3

1.1 Brief Introduction to RDK-N9H20 Demo Board 4

1.2 PCB key parts description 4

1.3 System Circuitry design notes 6

1.3.1 Main Clock6

1.3.2 RTC Clock6

1.3.3 RESET.....7

1.3.4 Power-on Setting7

1.3.5 Power Desing Notes8

2 PCB Layout Design Note..... 10

2.1 USB10

2.2 Signal integrity, SI11

2.3 Power supply and power filter design consideration12

2.3.1 DDR MVDD & Core Power 1.8V Design 12

2.3.2 I/O 3.3V Power Design..... 13

2.4 Main Clock 12MHz Design Suggestion.....14

2.5 RESET Layout Suggestion15

3 RDK-N9H20 demo board use description 16

3.1 System start up.....16

3.2 USB Port18

3.3 Communication Interface (UART0) uses.....18

3.4 LCD Interface.....18

4 Test Report..... 19

4.1 Power consumption19

4.2 ESD Test Report19

4.3 EFT Test Result.....19

4.4 EMI Test Result20

5 RDK-N9H20 demo board SCHEMATIC 22

5.1 N9H20 Schematic22

5.2 LCD Schematic.....23

5.3 Power Schematic24

6 REVISION HISTORY 25

1 OVERVIEW

The RDK-N9H20 is a general demo board installed the N9H20K51N chip which integrated 32MB DDR2 memory, users can verify emWin GUI application program easily.

The demo board includes one Micro USB connector for USB 2.0 high speed device controller for communication with PC, and the board also has a debugging UART port for system programming or debugging.

About display, the RDK-N9H20 demo board included one 4.3" LCD which the resolution is 480x272 with RGB-24bits and embedded the 4-wires resistive type touch panel.

For system booting, the RDK-N9H20 demo board supports one SPI-NOR Flash or one NAND Flash for selection depended on user demand.

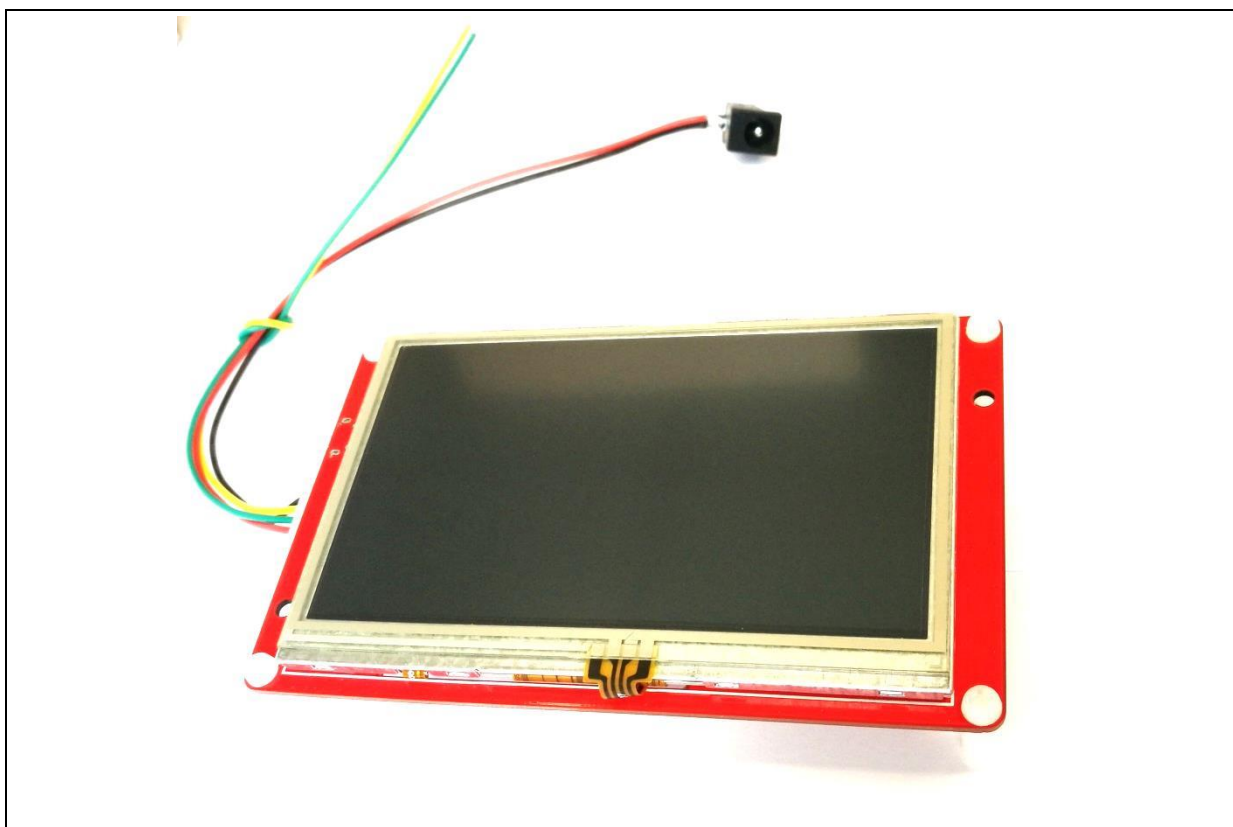

Figure 1-1 RDK-N9H20 demo board

1.1 Brief Introduction to RDK-N9H20 Demo Board

RDK-N9H20 demo board applied to HMI application, the purpose is for user have a reference design with emWin GUI accelerator platform. Thus that customers do not have to modify or only make simple changes could get a completed HMI hardware product quickly

The following figures show the RDK-N9H20 demo board, in which the PCB integrated Nuvoton N9H20K51N 32-bit microcontroller with CPU core ARM926EJ-S, speed runs up at 192MHz, with 16KB I-cache, 16 KB D-cache and MMU, 8KB SRAM and 12KB IBR(Internal Boot ROM) for booting sources from USB ,SPI-NOR Flash or NAND Flash selectable.

1.2 PCB key parts description

The PCB key parts are shown as the figure

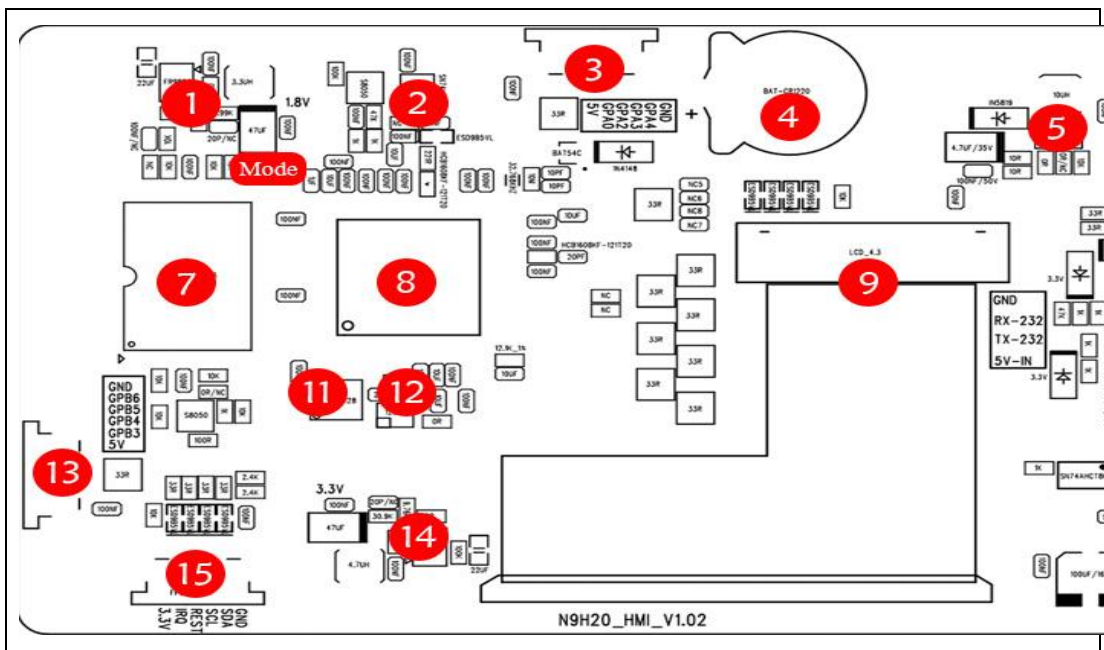

Figure 1-2 RDK-N9H20 PCB components side

① DDR/Core Power 1.8V	② CPU RESET
③ I/O_EXT with GPA0/2/3/4	④ RTC battery
⑤ LCD backlight driver	⑥ USB Device CON
⑦ NAND FLASH	⑧ N9H20K51N
⑨ LCD FC CON (RGB-24bits with TP)	⑩ DC5V power supply port
⑪ SPI-NOR FLASH	⑫ XTAL_12MHz
⑬ I/O_EXT with GPB/3/4/5/6	⑭ IO Power 3.3V
⑮ Reserved CON for CAP type TP	(Mode) Normal/USB recovery mode jumper

1.3 System Circuitry design notes

1.3.1 Main Clock

The system clock circuit is formed by the feedback circuit inside the chip and the external 12MHz crystal oscillation circuit. Recommended crystal connection mode and device parameters as shown in the figure below.

Note: The chosen capacitance needs to match the load capacitance of the crystal oscillator

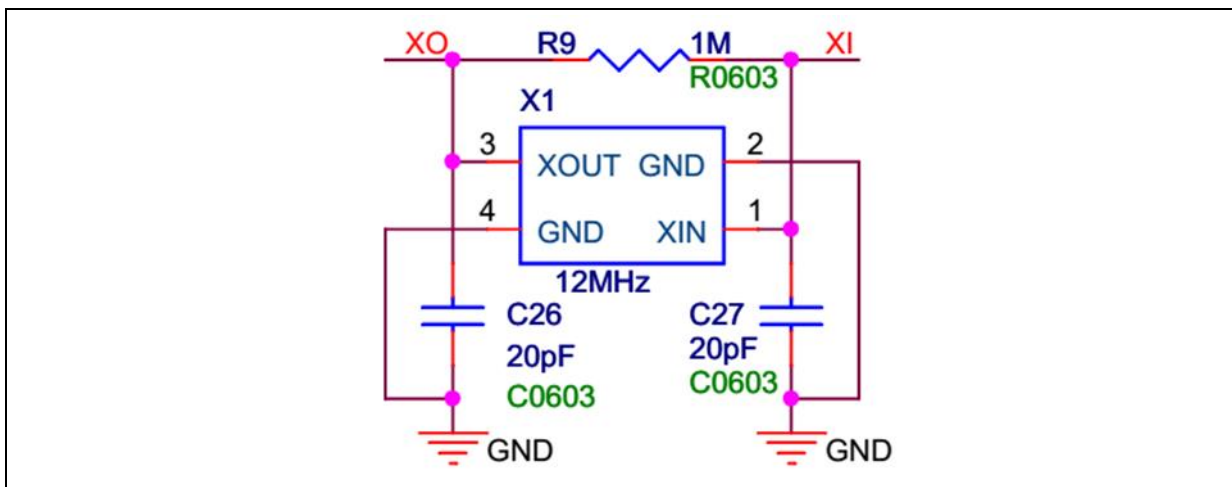

1.3.2 RTC Clock

N9H20K51N integrates the RTC function, the board needs to provide the RTC with the clock circuit, the recommended Crystal connection mode and the device parameters as shown in the figure below.

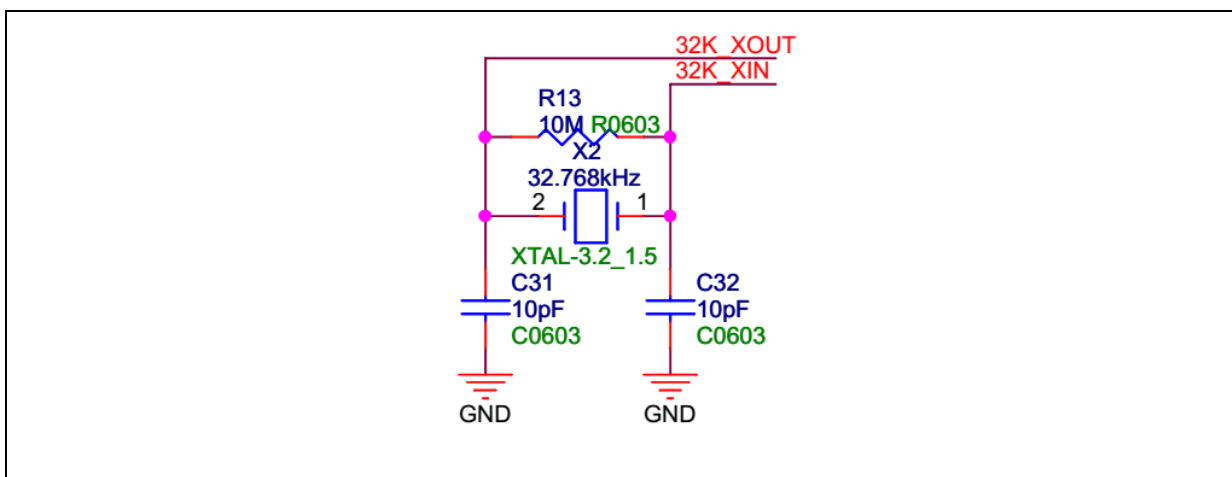

1.3.3 RESET

The nRST signal of the N9H20K51N is the reset signal input pin, and the required reset effective signal is a low-level pulse.

In order to stabilize the system robustness, it is recommended to use the following circuitry to implement reset signal. The RDK-N9H20 demo board reset circuitry and related passive device parameters as shown in the following figure.

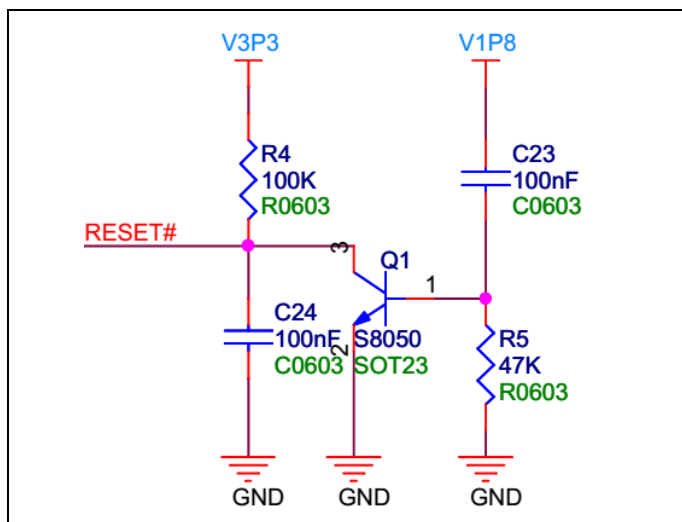

1.3.4 Power-on Setting

The power-on setting value is used to configure the chip to enter a specific state after power-up or reset. The power-on setting value will be kept in power-on setting control register for reference.

The following is the RDK-N9H20 demo board power-on setting circuitry and functions description.

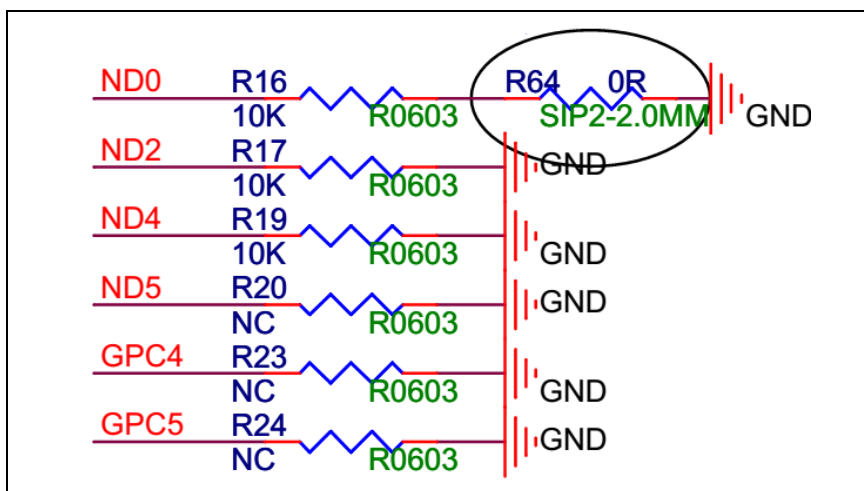

1.3.4.1 RDK-N9H20 demo board power-on setting description

ND0	Note
L	USB Recovery mode
H	Normal mode

ND2	Note
L	UART0 debug message output
H	UART0 message disable

ND5	ND4	DRAM type	Part No.
H	H	DDR	N9H20K31N
L	L	SDRAM	N9H20K11N
H	L	DDR2	N9H20K51N
L	H	LP-DDR	Reserved

PGC5	GPC4	NAND PAGE Size
H	H	Auto by IBR
H	L	8K
L	H	4K
L	L	2K

1.3.5 Power Desing Notes

RDK-N9H20 demo board power supply design have the below considerations

- For system core power (1.8V) design, it is recommended to select DC-DC part and the output capacity have 1A or above is better.
- For IO power (3.3V), in RDK-N9H20 demo board also uses DC-DC part, the concern is for LCD powered
- Power up sequence, the I/O (3.3V) power should be equal or fast than the core (1.8V) power and time gap between should control under within 500uS as the figure shown.
- Power-down sequence, the Core (2.8V) power should be equal or fast than the I/O (3.3V) power.

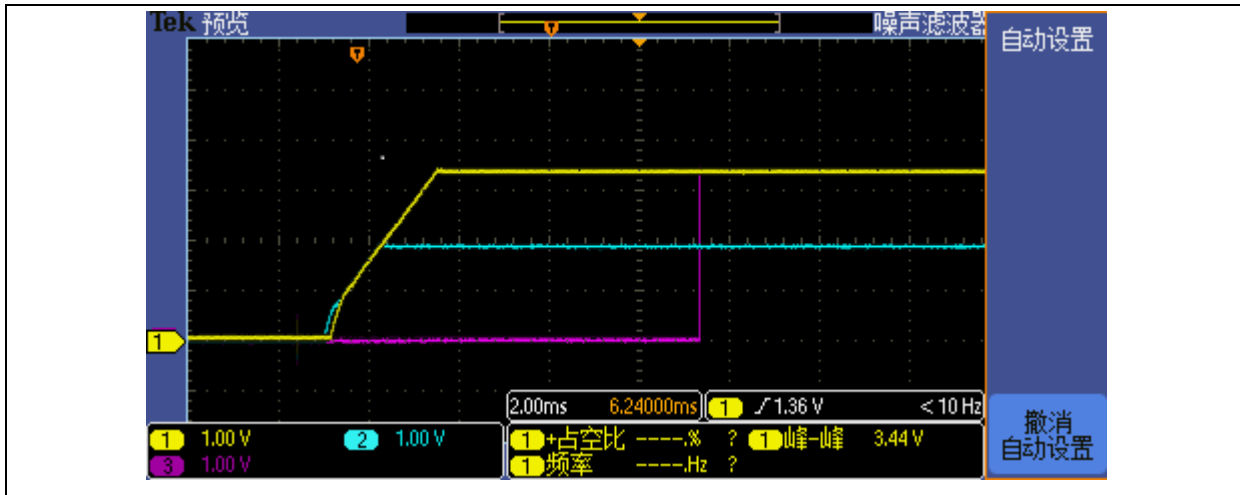

Note.

- Yellow line is I/O (3.3V)
- Blue line is core (1.8V)
- Purple line is nRST signal

2 PCB LAYOUT DESIGN NOTE.

RDK-N9H20 demo board is a 2-layers PCB and single component side design, for getting good performance and system quality have some suggestions as the below please follow.

2.1 USB

USB differential Line have 3 conditions as far as possible: 1, equal length; 2, equal width and 3, Equidistant

To do 90ohm $\pm 10\%$ impedance control. The double-layer plate can be controlled by the way of the impedance, that is, the differential line to do the GND shielding processing.

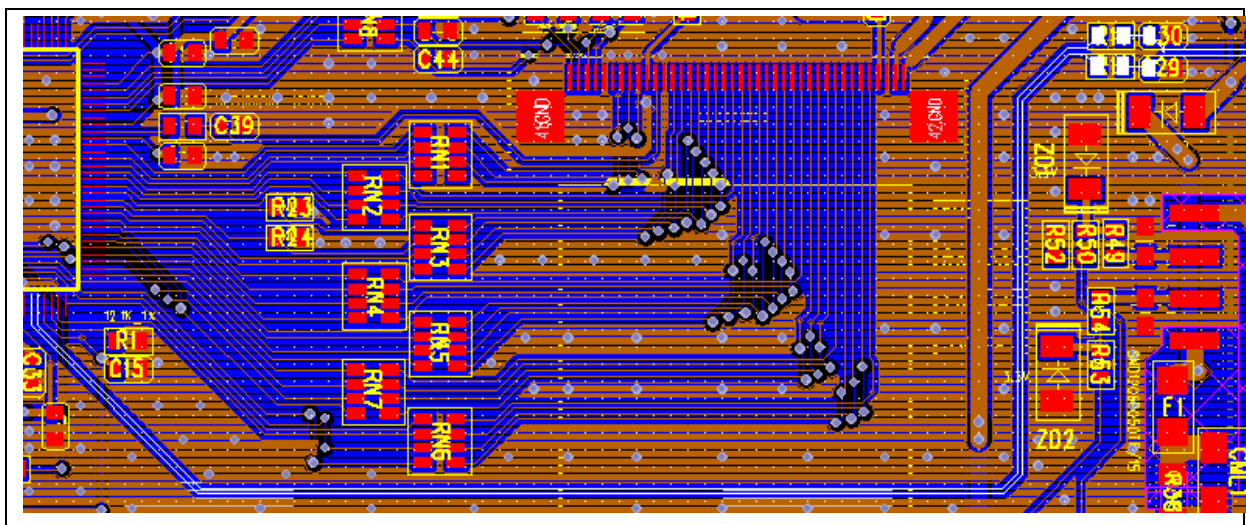

The RDK-N9H20 demo board USB eyes diagram result as the below figure

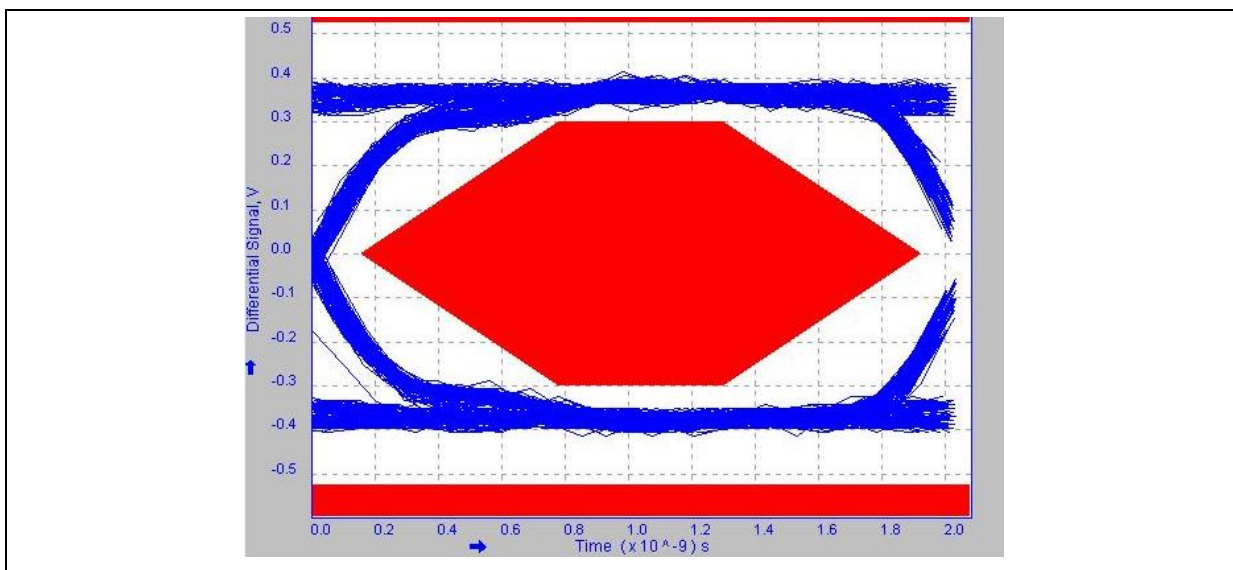

2.2 Signal integrity, SI

Due to 2- layers PCB does not have a separate GND plane, and to ensure the connectivity and integrity of the GND plane, the following requirements must be observed:

- The Bottom layer as far as possible or less device, to ensure the bottom surface of the GND integrity. Especially at the bottom of the main chip.,the RDK-N9H20 demo board that GND process at the bottom of main chip is shown in the following figure.

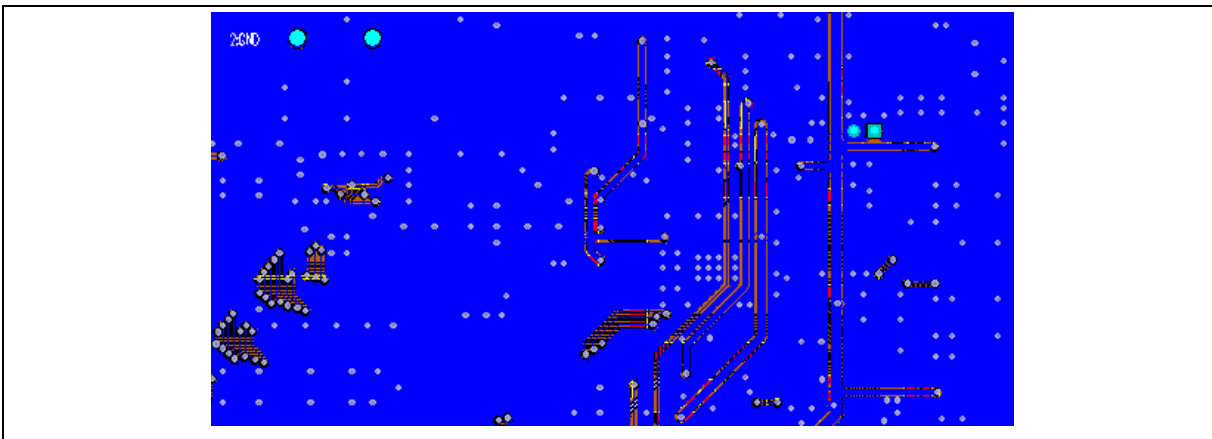

- If that is possible please place more via holes to GND to ensure that the top surface and the bottom surface of the GND copper skin connectivity.
- Ensure that there is no island of GND copper skin, as far as possible to ensure that as much as possible to connect the copper, so that the signal return path as short as possible.
- High-speed signal line under the bottom surface, as far as possible to ensure the complete GND plane, do not have to walk through the line.
- For critical signals, such as crystal oscillator, System Reset, I²C, USB, etc., need to be processed with shield GND all the way. The good shield GND process can guarantee the continuity of the impedance, anti-interference, and prevent EMI radiation.

The following figure is the LCD_CLK single connectivity with shield GND process

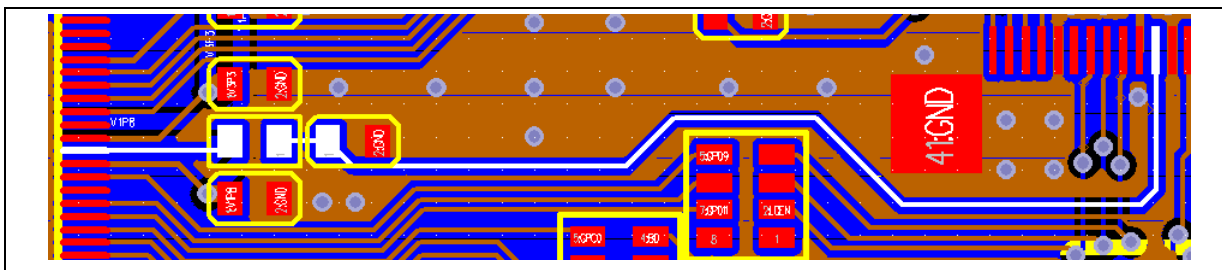

2.3 Power supply and power filter design consideration

2.3.1 DDR MVDD & Core Power 1.8V Design

About filter capacitance material and placement quantity

Capacity material recommended to use X7R material, placing quantity suggest that the corresponding chip should have at least one 104pF capacitors at the each supply pin, and some special entrances suggest placing the 104 pF+10 uF combination.

Detail please refer to RDK-N9H20 schematic diagram for details.

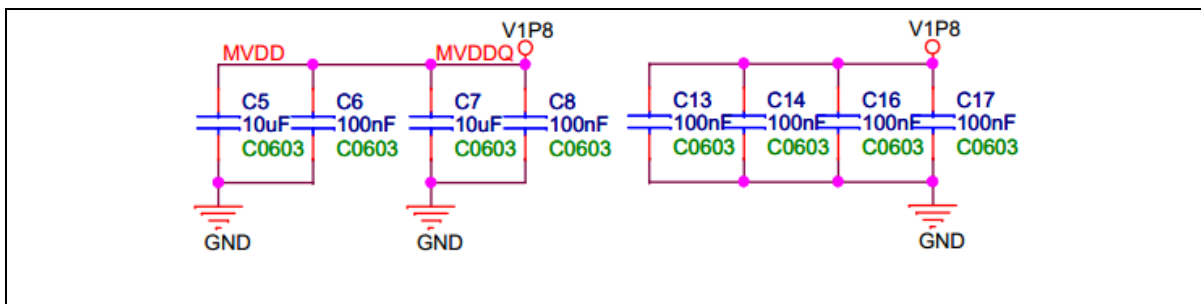

The layout pattern and the filter capacitance placement are shown in the image below.

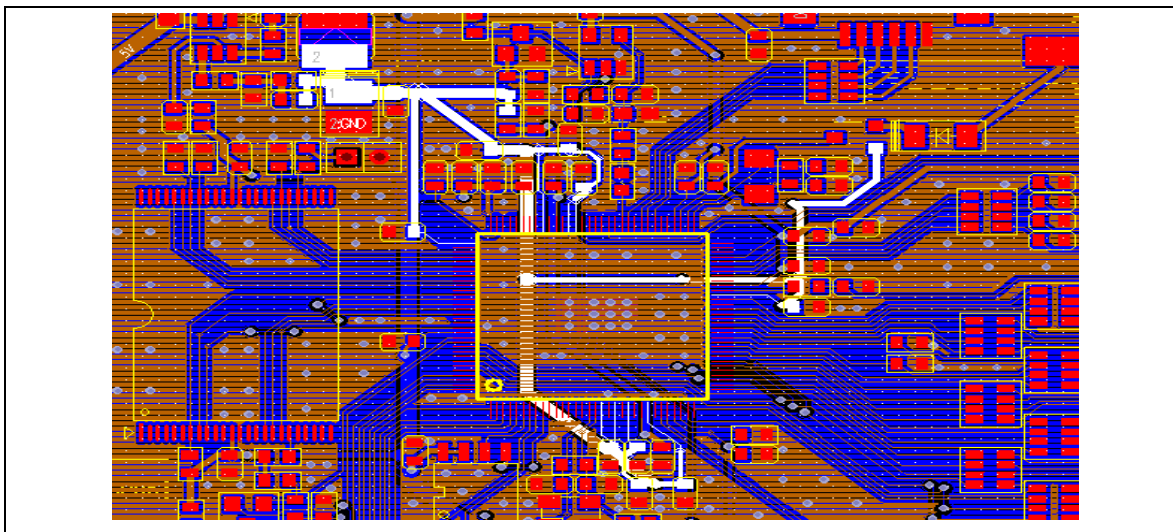

2.3.2 I/O 3.3V Power Design

About filter capacitance material and placement quantity

Capacity material recommended to use X7R material, placing quantity suggest that the corresponding chip should have at least one 104pF capacitors at the each supply pin, and some special entrances suggest placing the 104 pF+10 uF combination.

Detail please refer to RDK-N9H20 schematic diagram for details.

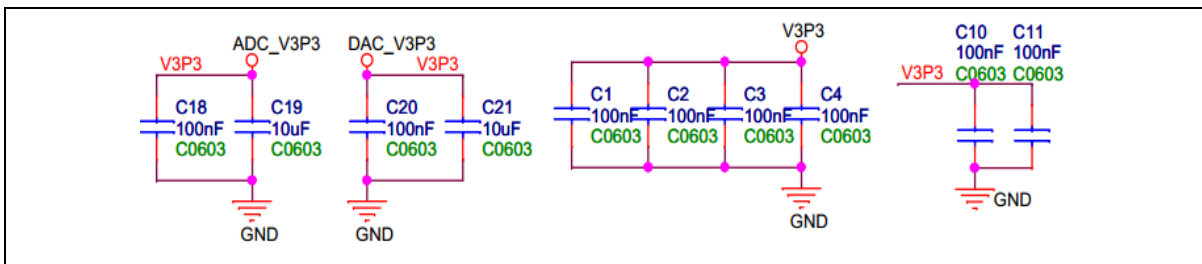

The layout pattern and the filter capacitance placement are shown in the image below.

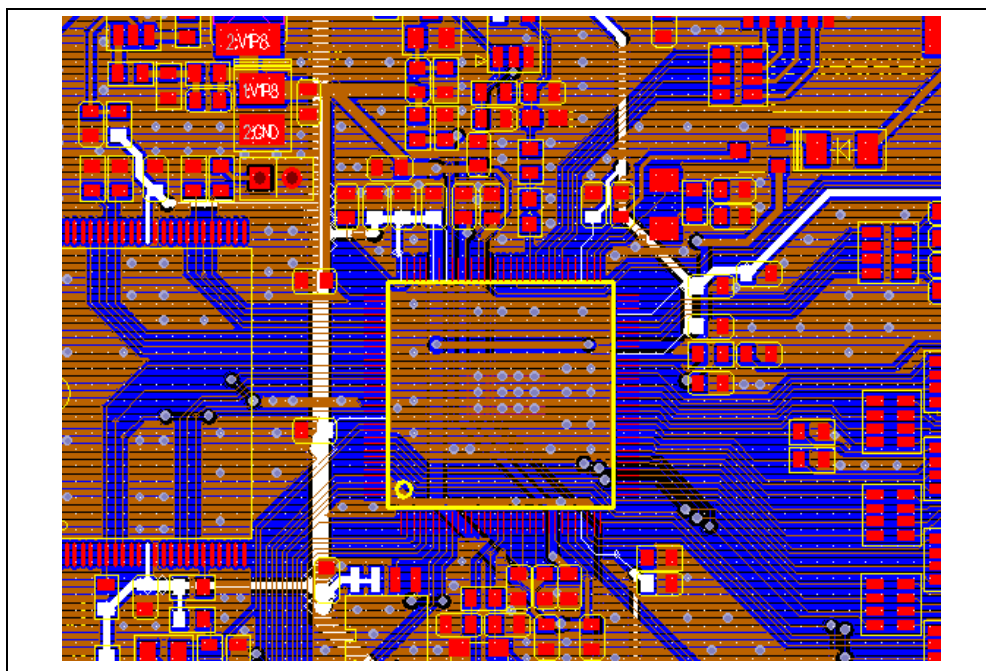

2.4 Main Clock 12MHz Design Suggestion

The 12MHz oscillator is the heart of the N9H20 chip and should be preferred in layout. Layout Basic principles: As close as possible to the chip pin, trace lines should be straight doesn't be bent, and important thing is that XTAL part at the bottom has a complete GND plane.

PCB layout skill was shown as below figure.

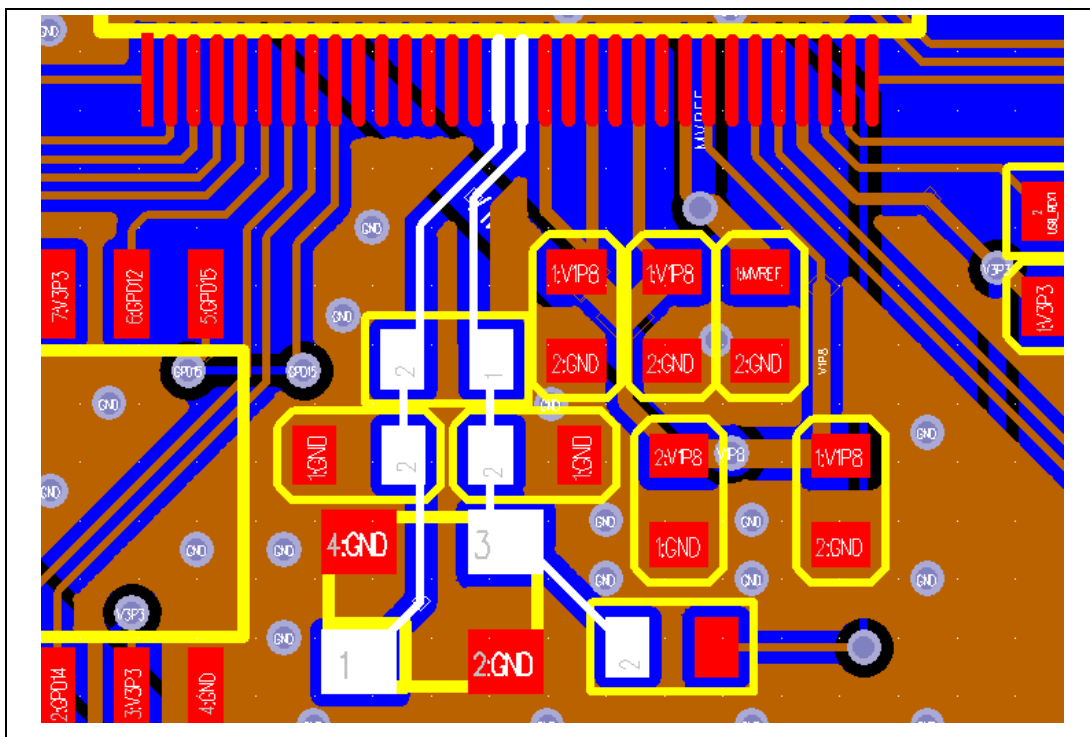

2.5 RESET Layout Suggestion

For system ESD capability and stability, the RESET signal design and layout traces routing are worth a comprehensive consideration to do that best protection.

Schematic details please refer to the schematic diagram of the RDK-N9H20, about the PCB layout was shown as below figure.

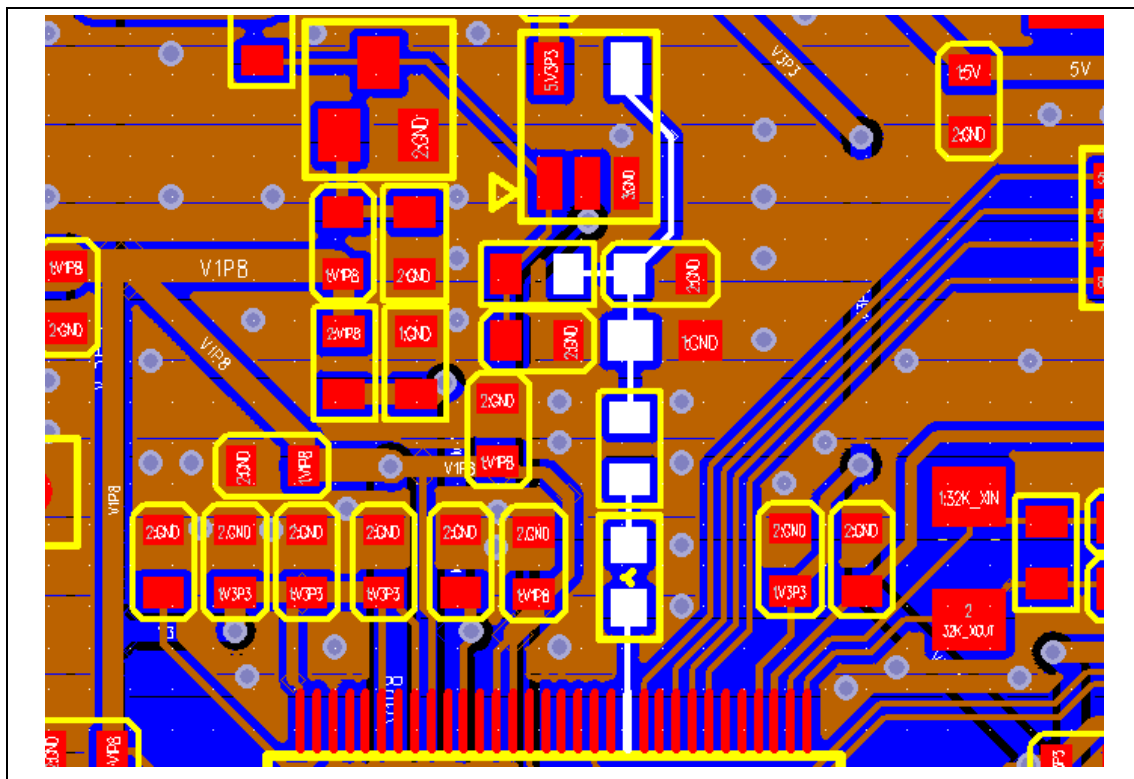

3 RDK-N9H20 DEMO BOARD USE DESCRIPTION

The RDK-N9H20 demo board is powered by DC +5V and is accessed by the CON3 pin-1 (+5V) and the pin-4 (GND).

The demo board system block as the figure.

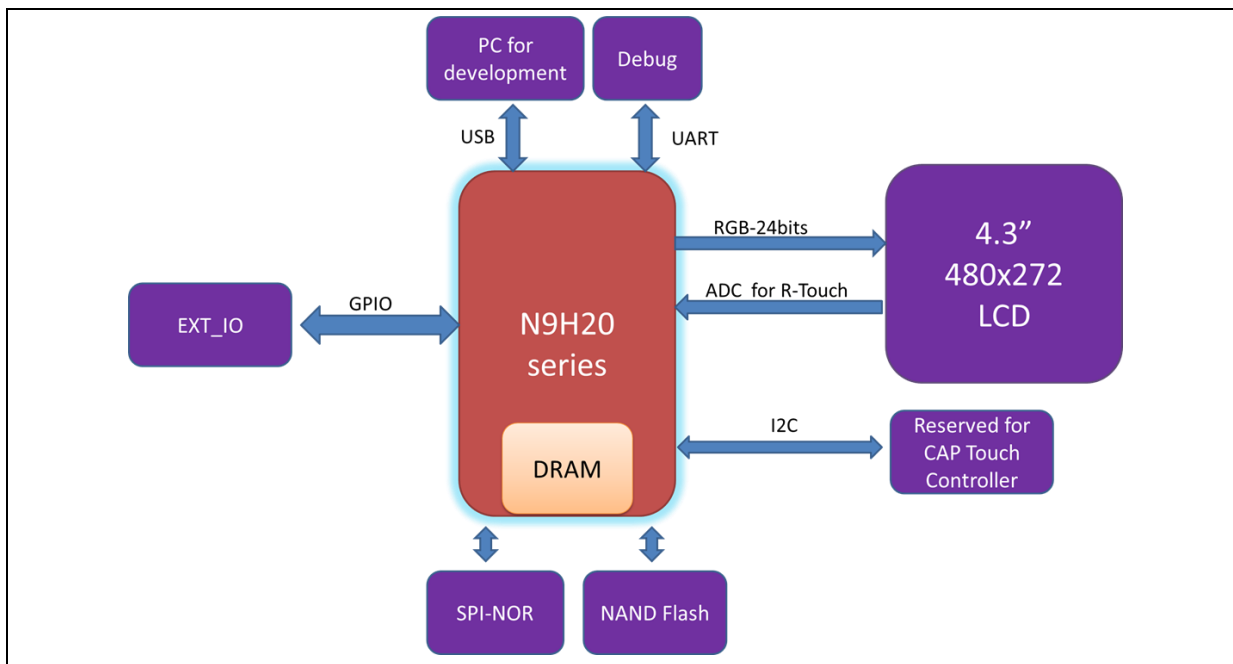

3.1 System start up

Mode switching by Normal/USB recovery mode jumper (i.e. R64 install or not) as the be low figure

- R64 pin un-install: Normal operation for NAND or SPI FLASH booting
- R64 pin installation: USB booting for code programming through writer tool of PC utility.

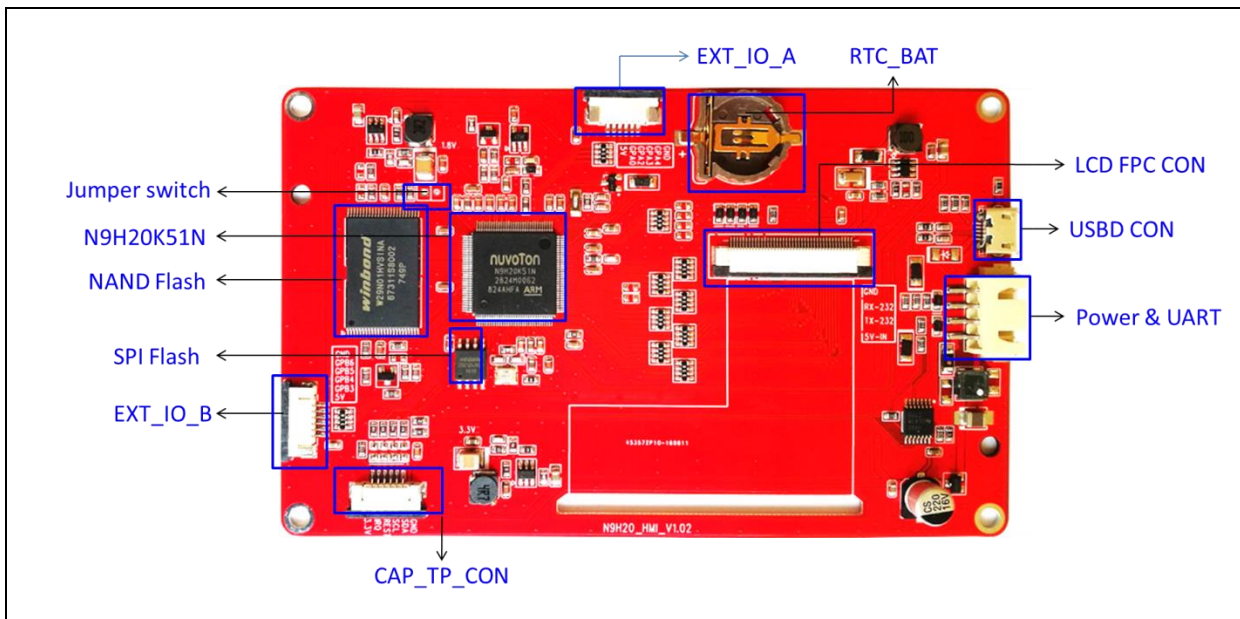
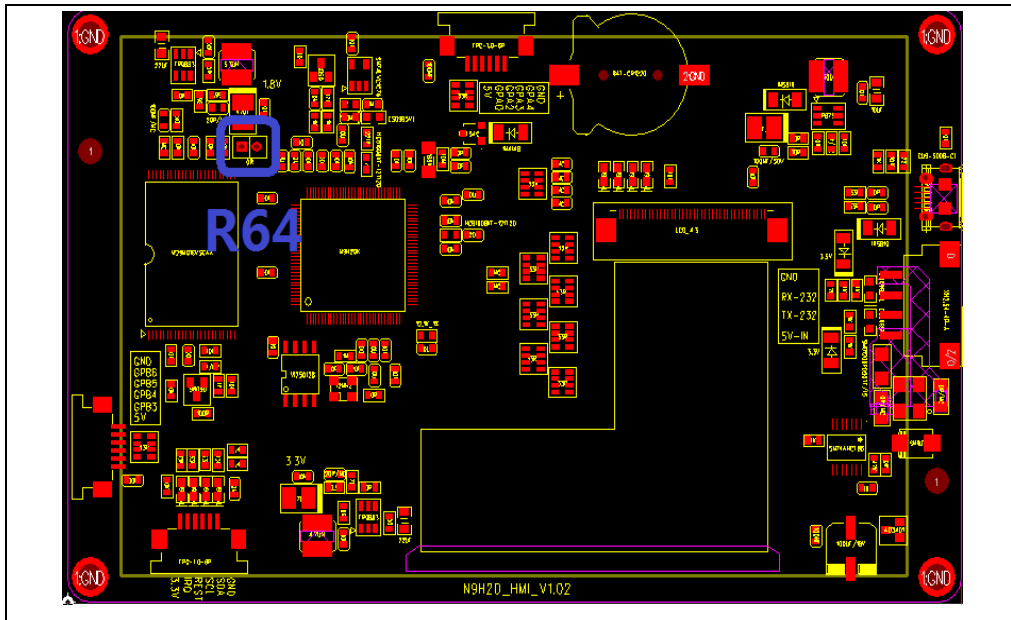

3.2 USB Port

The USB interface on the board is mainly used for burning the update program, this interface does not have the power supply capability. When using, please choose to connect with this interface USB extension cable connected with the PC and then power supply through the system supply port.CON3

3.3 Communication Interface (UART0) uses

CON3 interface is combined with UART0 serial port and +5V power supply, serial port level is standard TTL, communication baud rate is 115200bps.

The development period can be used for debug, which can be used for data interaction after the product.

3.4 LCD Interface

HMI-H9H20 demo board supports LCD interface with a 40-pin FPC connector, it is apply to 4.3" LCD resolution 480x272 RGB 24-bits and embedded 4-wires resistive type touch panel, the touch panel is connectivity with N9H20 ADC directly.

4 TEST REPORT

4.1 Power consumption

Condition : CPU@192MHz , emWin demo code is running

- Non-OS+emWin + 4.3 LCD : 5V@335mA
- Non-OS+emWin without LCD: 5V@98mA

4.2 ESD Test Report

- Contact (PCB GND & LCD metal) : +/- 4KV pass
- Air (LCD touch panel) : +/- 8KV pass
- Coupling (Horizontal & Vertical) : +/- 4KV pass

TR-4-E-004 Rev: A/0 ESD Immunity Test Data page 1 of 1

Standard	<input checked="" type="checkbox"/> IEC 61000-4-2 <input checked="" type="checkbox"/> EN 61000-4-2	Result: <input checked="" type="checkbox"/> PASS / <input type="checkbox"/> FAIL
Applicant: 芯唐 Sample No.: _____ Report No.: _____		
EUT: HMI M/N: N9H20		
Air Discharge: +/-8kV Criterion: B		
Contact Discharge: +/-4kV		
#For Positive and negative each 10 times		
Ambient Condition: 20 °C 49 %RH 101 kPa		
Input Voltage: 230 V 50 Hz		
Operation Mode: ON		
Location	Kind A-Air Discharge C-Contact Discharge	Results
LCD	A	PASS
METAL	C	PASS
HCP/VCP	C	PASS
Note:		
Test Equipment: TESEQ ESD Tester Model: NSG 437 No.: ATCE-127		

Discharge should be considered on Contact Air and Horizontal Coupling Plane(HCP) and Vertical Coupling plane(VCP).

Date: 2018-8-30 Test : WADE
Date: _____ Approve: _____

4.3 EFT Test Result

- EFT±4000V 5.0KHz pass

4.4 EMI Test Result

- EN55032 Test Result : Pass



ACCURATE TECHNOLOGY CO., LTD.

F1,Bldg,A,Changyuan New Material Port Keyuan Rd,
Science & Industry Park,Nanshan Shenzhen,P.R.China

Site: 2# Chamber
Tel:+86-0755-26503290
Fax:+86-0755-26503396

Job No.: 芯唐2018 #5	Polarization: Vertical
Standard: EN55032 CLASS B	Power Source: AC 230V/50Hz
Test item: Radiation Test	Date: 18/08/30/
Temp.(C)/Hum.(%) 23 C / 48 %	Time: 17/30/59
EUT:	Engineer Signature:
Mode:	Distance: 3m
Model: N9H20	
Manufacturer:	

Note: 2#

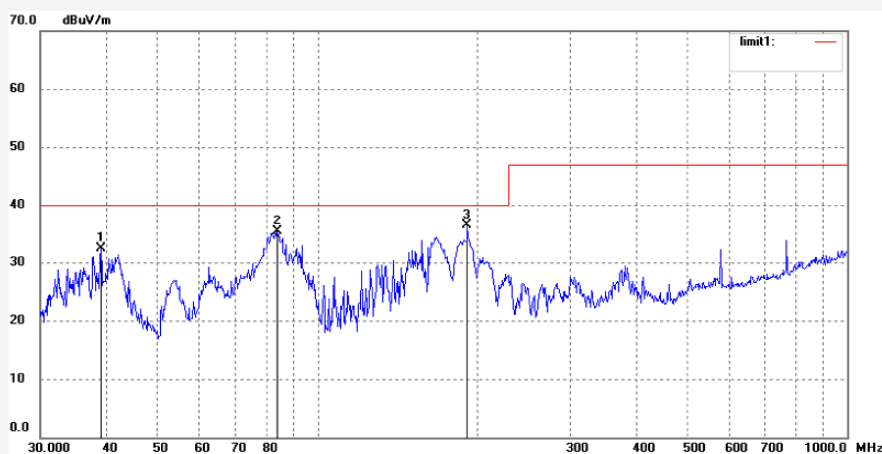

No.	Freq. (MHz)	Reading (dBuV/m)	Factor (dB)	Result (dBuV/m)	Limit (dBuV/m)	Margin (dB)	Detector	Height (cm)	Degree (deg.)	Remark
1	39.0245	43.75	-11.32	32.43	40.00	-7.57	peak			
2	84.1100	51.03	-15.53	35.50	40.00	-4.50	peak			
3	191.7450	48.94	-12.42	36.52	40.00	-3.48	peak			



ACCURATE TECHNOLOGY CO., LTD.

F1,Bldg,A,Changyuan New Material Port Keyuan Rd,
Science & Industry Park,Nanshan Shenzhen,P.R.China

Site: 2# Chamber
Tel:+86-0755-26503290
Fax:+86-0755-26503396

Job No.: 芯唐2018 #6	Polarization: Horizontal
Standard: EN55032 CLASS B	Power Source: AC 230V/50Hz
Test item: Radiation Test	Date: 18/08/30/
Temp.(C)/Hum.(%) 23 C / 48 %	Time: 17/33/33
EUT:	Engineer Signature:
Mode:	Distance: 3m
Model: N9H20	
Manufacturer:	

Note: 2#

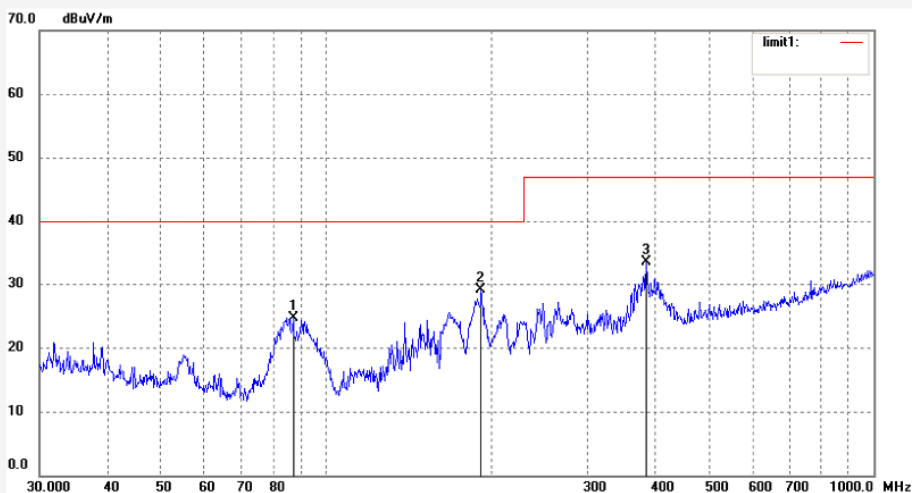

No.	Freq. (MHz)	Reading (dBuV/m)	Factor (dB)	Result (dBuV/m)	Limit (dBuV/m)	Margin (dB)	Detector	Height (cm)	Degree (deg.)	Remark
1	87.1117	39.94	-15.19	24.75	40.00	-15.25	peak			
2	191.7450	41.53	-12.42	29.11	40.00	-10.89	peak			
3	383.9318	40.49	-6.94	33.55	47.00	-13.45	peak			

5 RDK-N9H20 DEMO BOARD SCHEMATIC

5.1 N9H20 Schematic

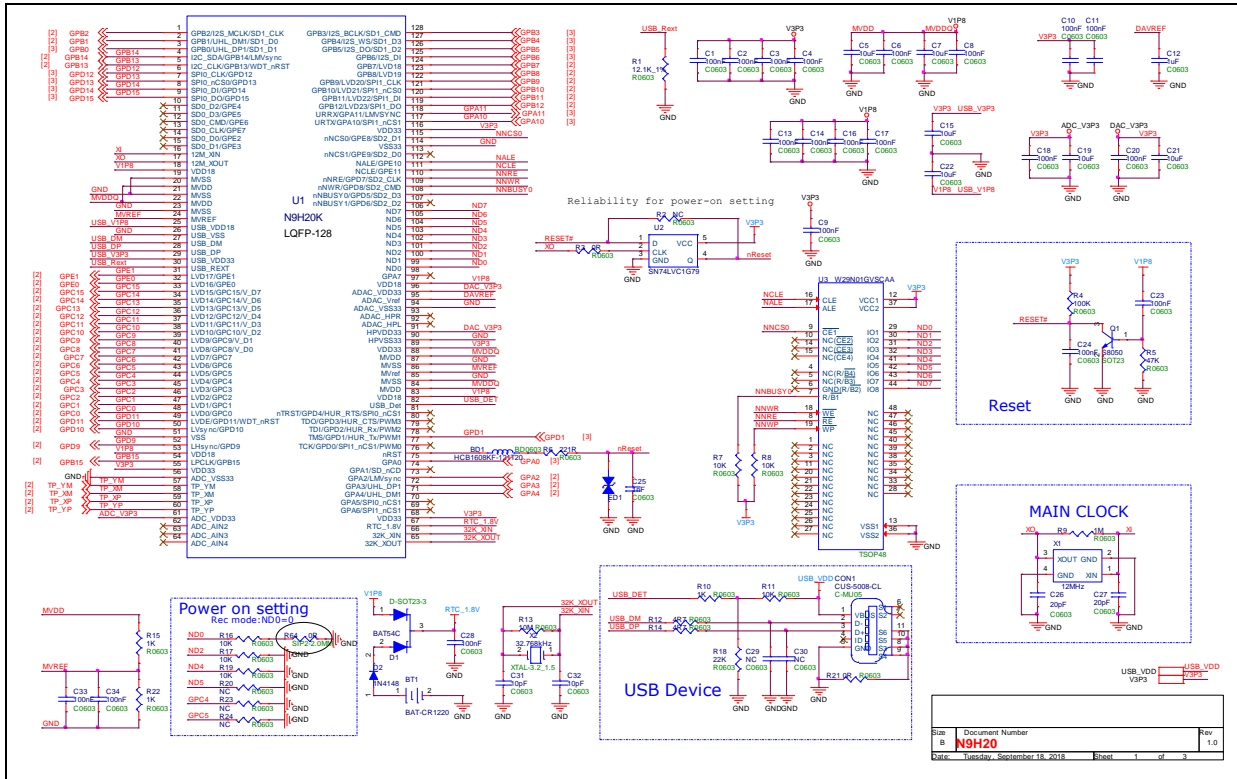

5.2 LCD Schematic

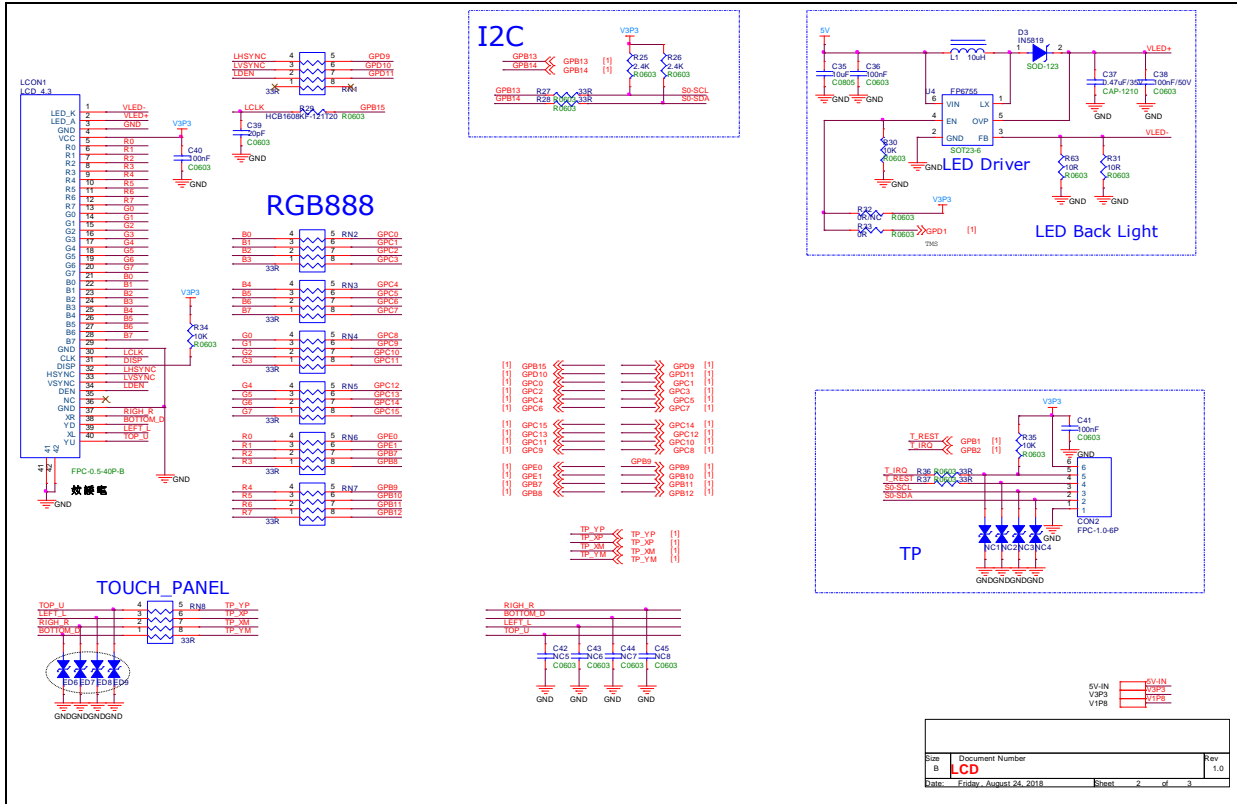

5.3 Power Schematic

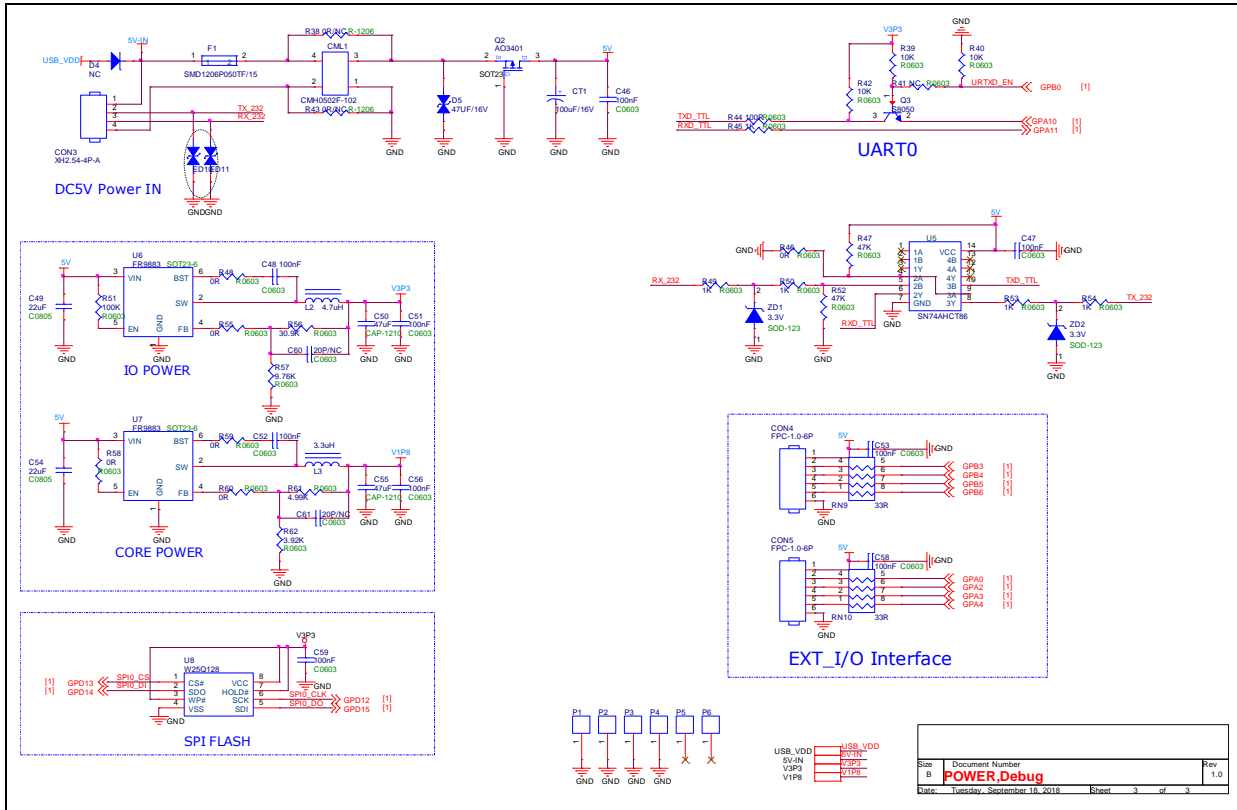

6 REVISION HISTORY

Date	Revision	Description
2018.09.25	1.00	Initially issued.

Important Notice

Nuvoton Products are neither intended nor warranted for usage in systems or equipment, any malfunction or failure of which may cause loss of human life, bodily injury or severe property damage. Such applications are deemed, "Insecure Usage".

Insecure usage includes, but is not limited to: equipment for surgical implementation, atomic energy control instruments, airplane or spaceship instruments, the control or operation of dynamic, brake or safety systems designed for vehicular use, traffic signal instruments, all types of safety devices, and other applications intended to support or sustain life.

All Insecure Usage shall be made at customer's risk, and in the event that third parties lay claims to Nuvoton as a result of customer's Insecure Usage, customer shall indemnify the damages and liabilities thus incurred by Nuvoton.

*Please note that all data and specifications are subject to change without notice.
All the trademarks of products and companies mentioned in this datasheet belong to their respective owners.*