

REV.	DESCRIPTION	DRAWN	DATE
1	INITIAL RELEASE	TIM	2020/04/16

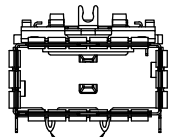

2 REAR LEGS

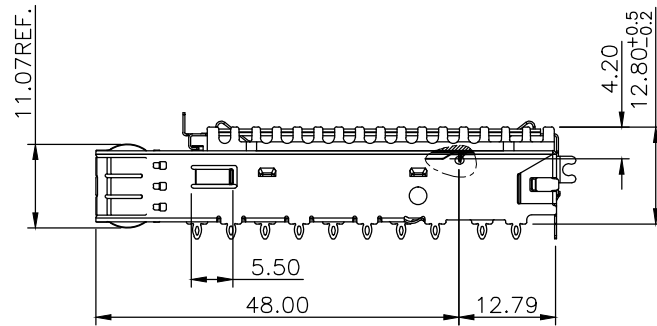
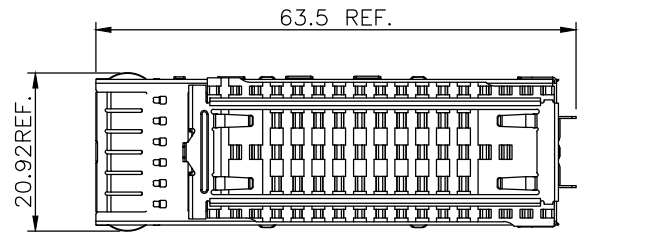
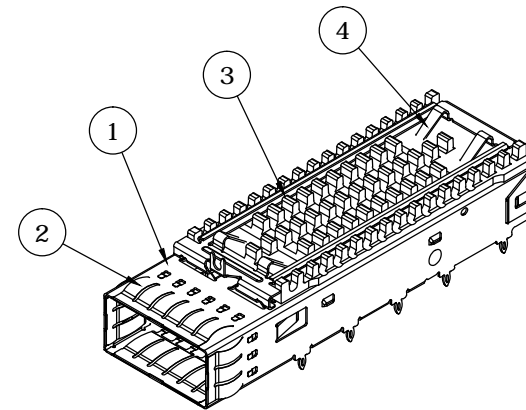
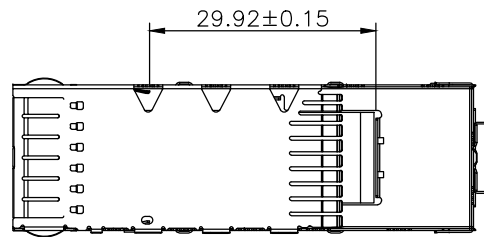

4	Heat Sink Clip	Stainless Steel
3	Heat Sink	Aluminum, Black Anodized
2	EMI Finger	Stainless Steel
1	Cage Body	Stainless Steel 0.25t

NO.	PART NAME	DESCRIPTION		
UNLESS OTHERWISE SPECIFIED TOLERANCE				
UNIT:	DECIMAL	LINEAR	ANGLES	
mm	X.	±0.50	±5°	
	X.X	±0.25	±3°	
	X.XX	±0.12	±1°	
DRAWN	Tim	2020/04/16	DRAWN NAME: QSF28 Connector, 1x1 Port Press Fit Type Cage with Heatsink	
CHECKED	Fros	2020/04/16		
APPROVED	Ken	2020/04/16	PRODUCT NO. 223C-1108	
SCALE 1/1		SHEET 1/2	SIZE A4	FILE NAME 223C-1108_B_1



WWW.ATTEND.COM.TW

REV.	DESCRIPTION	DRAWN	DATE
	SEE SHEET ONE		

NOTES:

- 1 DATUM X & Y ARE ESTABLISHED BY THE CUSTOMER'S FIDUCIAL
- 2. DATUM A IS THE TOP SURFACE OF THE HOST BOARD
- 3. LOCATION OF THE EDGE OF PCB IS APPLICATION SPECIFIC
- 4 BASELINE FOR THESE DIMENSIONS IS THE CENTER OF COMPLIANT PIN HOLE.
- 5 FINISHED HOLE SIZE
- 6 REFER TO SFF8662 FOR CONNECTOR FOOTING DIMENSIONS
- 7 SURFACE TRACES PERMITTED WITHIN THIS SHADED AREA

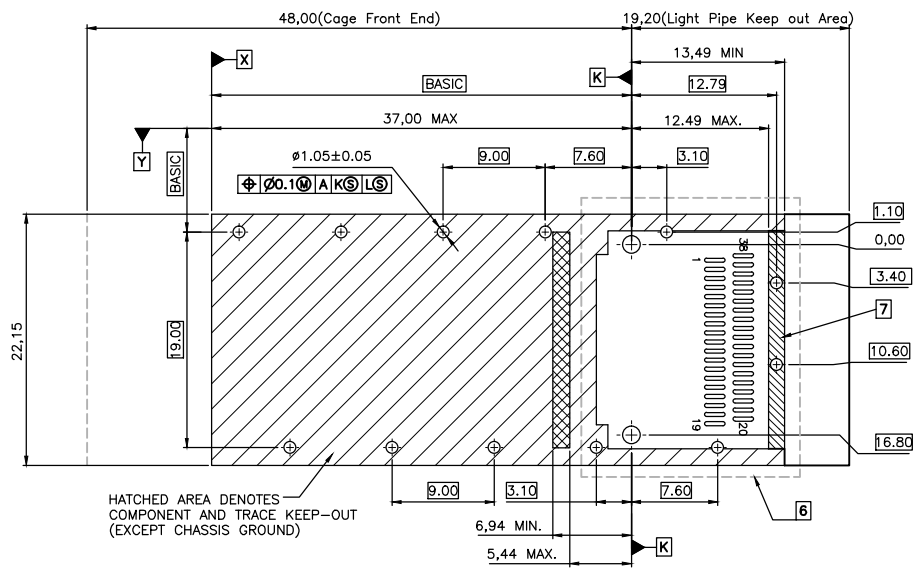

RECOMMENDED PC BOARD LAYOUT

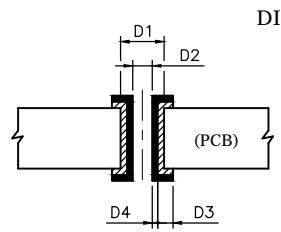

DIMENSIONS NOTE:

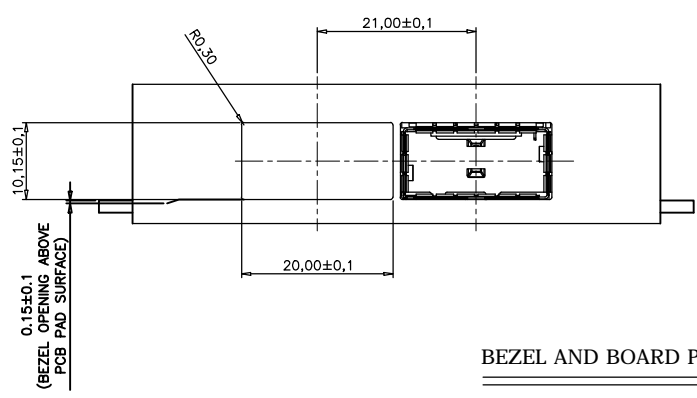

- D1: 1.15±0.02
- D2: 1.05±0.05
- D3: 0.025~0.05mm
- D4: 0.004~0.01mm Hot Air Solder Leveling (HASL) Tin-Lead
0.0005mm min. Immersion Tin
0.0002~0.0005mm Organic Solderability Preservative (OSP)
0.004~0.0076mm Nickel, 0.0001~0.0005 Immersion Gold

FINISHED HOLE SIZE SPECS

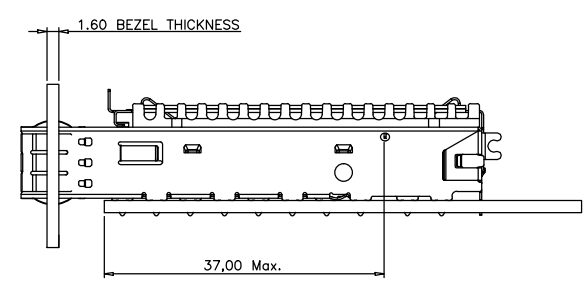

BEZEL AND BOARD POSITION DIMENSION



UNLESS OTHERWISE SPECIFIED TOLERANCE				 WWW.ATTEND.COM.TW
UNIT:	DECIMAL	LINEAR	ANGLES	
mm	X.	±0.50	±5°	
	X.X	±0.25	±3°	
	X.XX	±0.12	±1°	
DRAWN	Tim	2020/04/16	DRAWN NAME:	
CHECKED	Fros	2020/04/16	QSF28 Connector, 1x1 Port Press Fit Type Cage with Heatsink	
APPROVED	Ken	2020/04/16	PRODUCT NO. 223C-1108	
	SCALE	SHEET	SIZE	FILE NAME
	1/1	2/2	A4	223C-1108_B_1