

DATE	REV	ECN	APP'D. BY
1-16-15	A6	10207	TRM
2-26-16	A7	10572	TRM

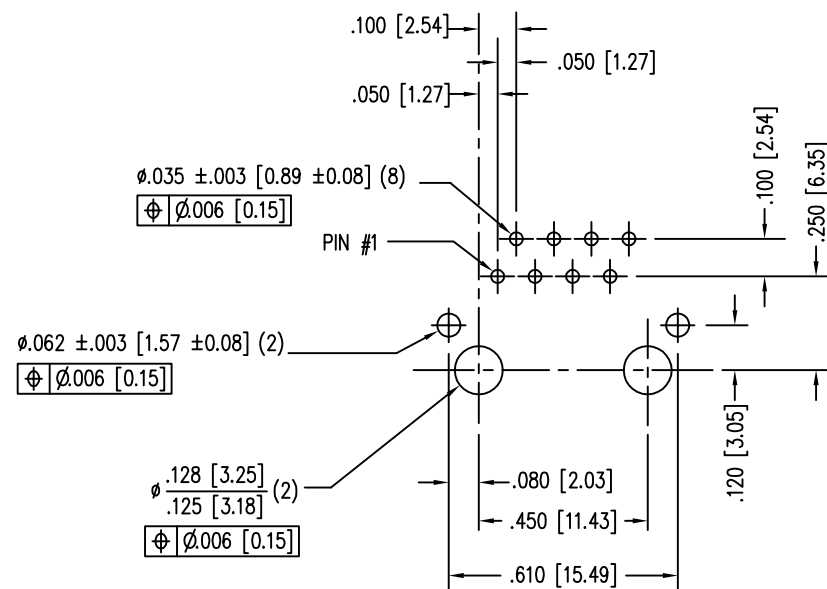
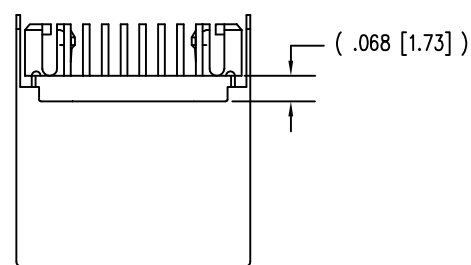
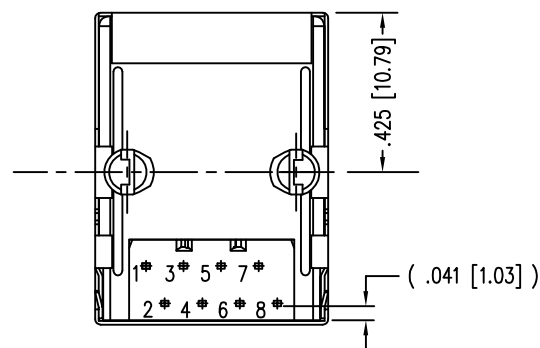
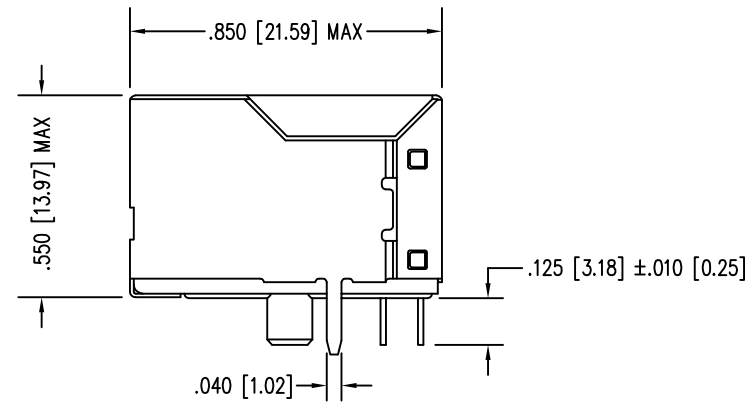
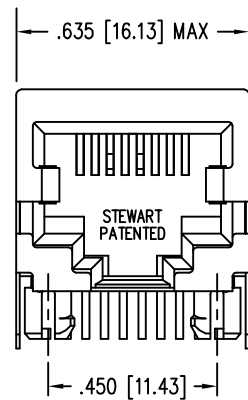

P.C.B. RECOMMENDED HOLE LAYOUT  
SEEN FROM COMPONENT SIDE  
ALL CENTERLINE DIMENSIONS ARE BASIC.

NOTES:

- CONNECTOR MATERIALS:  
HOUSING: THERMOPLASTIC UL94 V-0  
CONTACTS/SHIELD: COPPER ALLOY  
SHIELD PLATING: NICKEL OR TIN  
CONTACT PLATING: SELECTIVE GOLD IN CONTACT AREA  
SEE CHART FOR PART NUMBER
- FOR PRODUCT SPECIFICATIONS SEE PR022-01.
- DIMENSIONS AND TOLERANCES COMPLY WITH FCC/CFR 47, PART 68.
- DESIGNED FOR CATEGORY 5/5e APPLICATIONS.

50 MICRO-INCHES [1.27um]	SS-7188S-A-NF-50
30 MICRO-INCHES [0.76um]	SS-7188S-A-NF
CONTACT PLATING IN MATING AREA	PART NUMBER

THIRD ANGLE PROJECTION

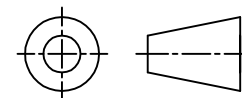

1118 Susquehanna Trail South  
Glen Rock, PA 17327-9199  
(717) 235-7512

<http://www.stewartconnector.com>

DO NOT SCALE DRAWING  
DRAWING IS SUBJECT TO  
CHANGE WITHOUT NOTICE

TITLE: EIGHT CONTACT, EIGHT POSITION SHIELDED JACK

DIMENSIONS: INCHES [METRIC]  
UNLESS OTHERWISE SPECIFIED  
TOLERANCES ARE ±.005 [0.13]  
ANGLES ARE ± 1°

THIS DRAWING AND THE SUBJECT MATTER SHOWN THEREON  
ARE CONFIDENTIAL AND THE PROPRIETARY PROPERTY OF  
STEWART CONNECTOR AND SHALL NOT BE REPRODUCED,  
COPIED, OR USED IN ANY MANNER WITHOUT PRIOR WRITTEN  
CONSENT OF STEWART CONNECTOR. ONE OR MORE U.S. PATENTS  
MAY APPLY TO THIS PRODUCT. FOR DETAILS, PLEASE  
VISIT: [HTTP://BELFUSE.COM/STEWART/STEWART\\_PATENTS/](http://BELFUSE.COM/STEWART/STEWART_PATENTS/)

DRN BY:	RVO	DATE	2-1-05
APPD BY:	RGC	DATE	2-22-05
DWG NO.	CT710001	REV.	A7

SHEET NO. 1 OF 1

