

# FTDI Chip

## VM800B Datasheet

### Embedded Video Engine

### Basic module



*General Purpose Multi Media Controller*

## 1 Introduction

The VM800B is a development module for FTDI's FT800, which is used to develop and demonstrate the functionality of the FT800 Embedded Video Engine, EVE.

This module behaves as an SPI slave, and requires a SPI Master for proper micro-controller interfacing and system integration.

VM800B modules support 3 different LCD panel size options and are designed for industrial or commercial environments with precision fitted bezels in either black (-BK) or pearl (-PL).

- VM800B35A-xx is the 3.5" LCD
- VM800B43A-xx is the 4.3" LCD
- VM800B50A-xx is the 5.0" LCD

## 1.1 Features

The VM800B utilises the FTDI FT800 Embedded Video Engine, EVE. Graphic, audio and touch features of the FT800 chip can be accessed with the VM800B. For a full list of the FT800's features please see the FT800 datasheet. The VM800B has the following features:

- Ready to use LCD module.
- Integrated with resistive touch screen LCD panel
- On board LCD backlight LED Driver
- On board audio power amplifier and micro speaker
- Flexible power supply. Powering the VM800B using either a 2.1mm power jack , SPI master connector or via USB Micro-B port
- 5 V tolerant buffers when used with a 5V SPI Master
- Precision fitted bezel in black(-BK) or pearl (-PL)

Neither the whole nor any part of the information contained in, or the product described in this manual, may be adapted or reproduced in any material or electronic form without the prior written consent of the copyright holder. This product and its documentation are supplied on an as-is basis and no warranty as to their suitability for any particular purpose is either made or implied. Future Technology Devices International Ltd will not accept any claim for damages howsoever arising as a result of use or failure of this product. Your statutory rights are not affected. This product or any variant of it is not intended for use in any medical appliance, device or system in which the failure of the product might reasonably be expected to result in personal injury. This document provides preliminary information that may be subject to change without notice. No freedom to use patents or other intellectual property rights is implied by the publication of this document. Future Technology Devices International Ltd, Unit 1, 2 Seaward Place, Centurion Business Park, Glasgow G41 1HH United Kingdom. Scotland Registered Company Number: SC136640

## 2 Ordering Information

Note that the kits below require a 5V/1A power supply. It is NOT provided in the development kit, but is offered as an optional accessory with the following part types:

Part No.	Description
VM800B35A-BK	VM800B module, supports 3.3/5v MCU Adapter Board, 3.5 inch TFT LCD display panel preinstalled, black bezel
VM800B43A-BK	VM800B module, supports 3.3/5v MCU Adapter Board, 4.3 inch TFT LCD display panel preinstalled, black bezel
VM800B50A-BK	VM800B module, supports 3.3/5v MCU Adapter Board, 5.0 inch TFT LCD display panel preinstalled, black bezel
VM800B35A-PL	VM800B module, supports 3.3/5v MCU Adapter Board, 3.5 inch TFT LCD display panel preinstalled, pearl bezel
VM800B43A-PL	VM800B module, supports 3.3/5v MCU Adapter Board, 4.3 inch TFT LCD display panel preinstalled, pearl bezel
VM800B50A-PL	VM800B module, supports 3.3/5v MCU Adapter Board, 5.0 inch TFT LCD display panel preinstalled, pearl bezel
VA-PSU-UK1	Accessory - UK Model 5V/1A USB Power Supply (Mfr # JX-B0520C-1-B)
VA-PSU-US1	Accessory - US Model 5V/1A USB Power Supply (Mfr # JX-B0520B-1-B)
VA-PSU-EU1	Accessory - EU Model 5V/1A USB Power Supply (Mfr # JX-B0520A-1-B)
VA800A-SPI	Accessory - High Speed Micro USB to SPI adapter for BASIC boards based on FT232H MPSSE design
VA-FC-1M-BKW	Accessory - Flat USB A to Micro B Cable 1M- Black and White
VA-FC-1M-BLW	Accessory - Flat USB A to Micro B Cable 1M- Blue and White
VA-FC-STYLUS1	Accessory - Resistive Touch Screen Pen Stylus

**Table 2-1 – Ordering information**

Note: 3.5" display resolution is 320 x 240 (QVGA).

4.3"/5.0" display resolution is 480 x 272 (WQVGA)

## Table of Contents

<b>1</b>	<b>Introduction .....</b>	<b>1</b>
1.1	Features.....	1
<b>2</b>	<b>Ordering Information .....</b>	<b>2</b>
<b>3</b>	<b>Hardware Description .....</b>	<b>4</b>
3.1	VM800B module .....	4
3.2	Physical Descriptions .....	5
3.2.1	PCB layout.....	5
3.2.2	VM800B Connectors.....	6
<b>4</b>	<b>Board Schematics.....</b>	<b>9</b>
<b>5</b>	<b>Hardware Setup Guide .....</b>	<b>13</b>
5.1	Power Configuration .....	13
5.2	MPSSE Setup.....	13
5.3	Arduino® Setup .....	15
<b>6</b>	<b>Assembling the Bezel and Panel Mounting .....</b>	<b>16</b>
6.1	3.5" Dimensions.....	17
6.2	4.3" Dimensions.....	18
6.3	5.0" Dimensions.....	19
<b>7</b>	<b>Specifications.....</b>	<b>20</b>
7.1	Optical Specification .....	20
<b>8</b>	<b>Contact Information.....</b>	<b>23</b>
	<b>Appendix A - References .....</b>	<b>23</b>
	Document References .....	23
	<b>Appendix B - List of Figures and Tables .....</b>	<b>24</b>
	List of Figures .....	24
	List of Tables .....	24
	<b>Appendix C – Revision History .....</b>	<b>25</b>

### 3 Hardware Description

Please refer to section 3.2.2 for connector settings. Some VM800B jumpers must be set to work properly with your system.

#### 3.1 VM800B module



**Figure 3-1 – VM800B module profile 3.5” display version**



**Figure 3-2 - VM800B module profile 4.3” display version**



**Figure 3-3 - VM800B module profile 5” display version**

NOTE: Also available in pearl.

The VM800B module is intended for direct use into existing applications that require a display. This module is suitable for interfacing with an external microcontroller that has a SPI Master channel.

The VM800B module is available in multiple options: 3.5, 4.3 or 5.0 inch display options.

The main functions of the VM800B are as follows:

- Micro USB connector
- SPI connector
- 2-pin connector for power supply
- 3.3V regulator: Takes 5V input and outputs 3.3V for on-board circuits
- LCD touch screen panel
- 5V tolerant buffers between the SPI master interface and the Slave interface of the FT800
  - SPI timing requirements can be found in the FT800 datasheet. The on board level converter buffers introduce additional delay. The actual maximum SPI clock frequency depends on the host system timing and connection cable length to the VM800B PCB.
- 3 stage audio filter and power amplifier
- 8Ω speaker
- Audio line out option
- Precision fitted bezel

## 3.2 Physical Descriptions

### 3.2.1 PCB layout

The VM800B module PCB layouts are illustrated in Figure 3-4 and Figure 3-5. Boards are four-layer, approximately 1.6 mm thickness.

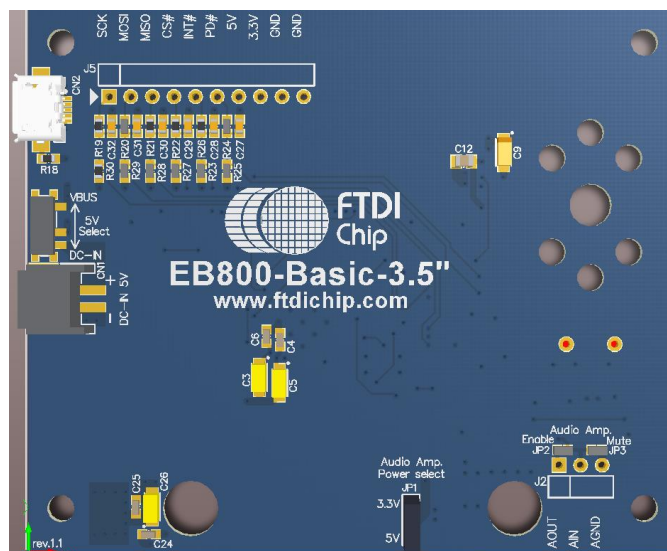

**Figure 3-4 - VM800B module PCB view, 3.5 inch display version**

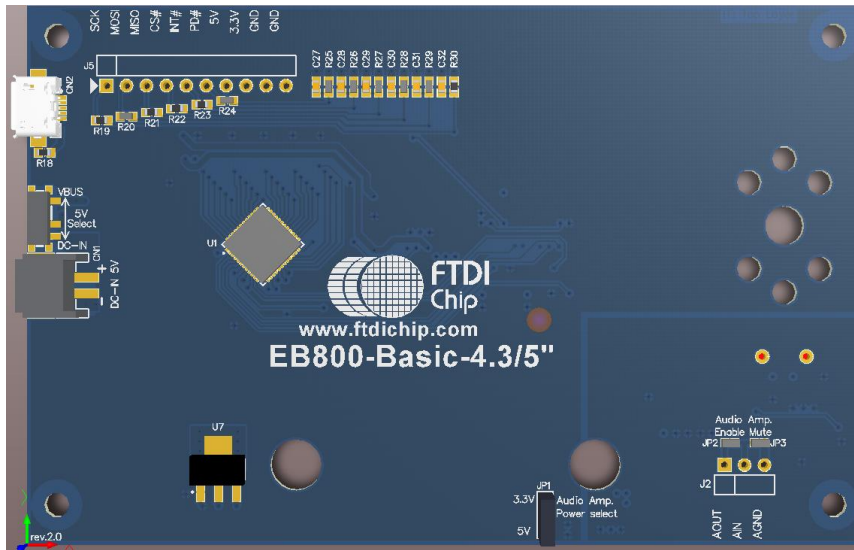
**Figure 3-5 - VM800B module PCB view, 4.3 and 5 inch display version**

### 3.2.2 VM800B Connectors

Connectors and jumpers are described in the following sections.

- **CN1- 2-pin power connector**

2 pin connector for 5V/3.3V power input to the board. Alternative to Micro USB connector.

Pin No.	Name	Type	Description
1	VCC	P	5V or 3.3V DC power supply
2	GND	P	Ground

**Table 3-1 – CN1 Pinout**

- **CN2- Micro USB Receptacle**

This receptacle is strictly for 5V input to power the board. There is no USB Functionality

Pin No.	Name	Type	Description
1	VBUS	P	5V power supply
2	NC	NA	No connection
3	NC	NA	No connection
4	NC	NA	No connection
5	GND	P	Ground

**Table 3-2 – CN2 Pinout**

- **J2 - Selection between Lineout and loop back into the power amplifier.**

Selection between audio lineout and loop back into the power amplifier.

Jumper position	Description
Short pin 1-2	Audio amp enabled (default)
Short pin 2-3	Audio amp mute, Audio lineout on pin 1

**Table 3-3 – J2 Pin Options**

- **J5- SPI Interface**

This is the interface where the SPI control and data signals are routed too. There are also power and ground pins on this interface.

Pin No.	Name	Type	Description
1	SCLK	I	SPI Clock input, 3.3V (5V tolerant)
2	MOSI	I	Master Out Slave in, 3.3V (5V tolerant)
3	MISO	O	Master In Slave out, 3.3V
4	CS#	I	Chip select , active low, 3.3V (5V tolerant)
5	INT#	O	Interrupt output active low, 3.3V
6	PD#	I	Power down control input, active low , 3.3V (5V tolerant)
7	5V	P	5V power supply
8	3.3V	P	3.3V power supply
9	GND	P	Ground
10	GND	P	Ground

**Table 3-4 – J5 Pinout**

- **JP1- Audio Amplifier Power Select**

This jumper provides the option to select the power supply voltage for the on-board power amplifier.

Jumper position	Description
Short pin 1-2	3.3V selected (default)
Short pin 2-3	5V selected

**Table 3-5 – JP1 Pin options**

\*This needs to be configured before audio can be heard. Default is 3.3V. Select 5V if wants to increase the maximum volume for the speaker.

- **JP2 – On board amplifier enable**

Solder connection not fitted by default.

- **JP3 - On board amplifier mute**

Solder connection not fitted by default.

---

- **SW1 – Power source select**

<b>Jumper position</b>	<b>Description</b>
Short pin 1-2	Board power from CN1
Short pin 2-3	Board power from CN2 (default)

**Table 3-6 – SW1 jumper options**



# 4 Board Schematics

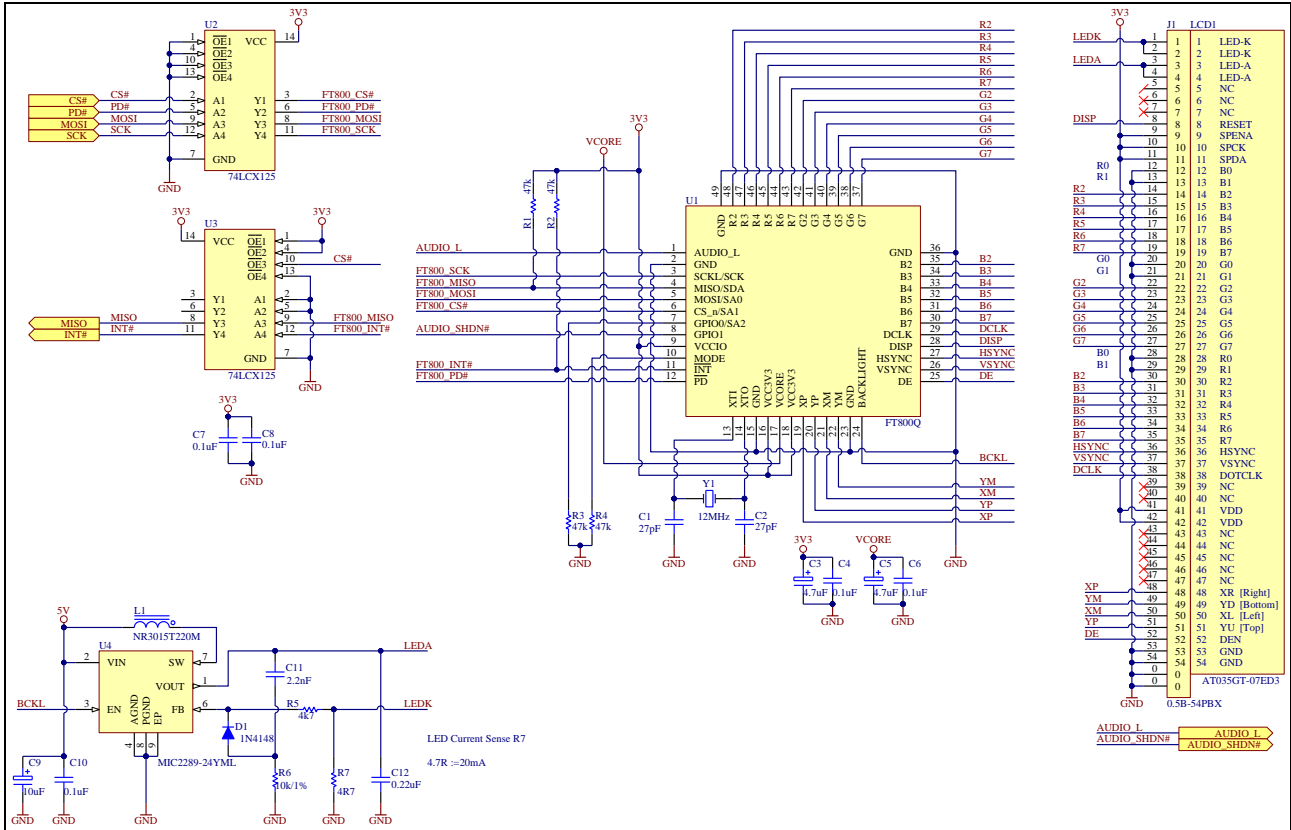

**Figure 4-1 - VM800B35A (3.5" Version)**

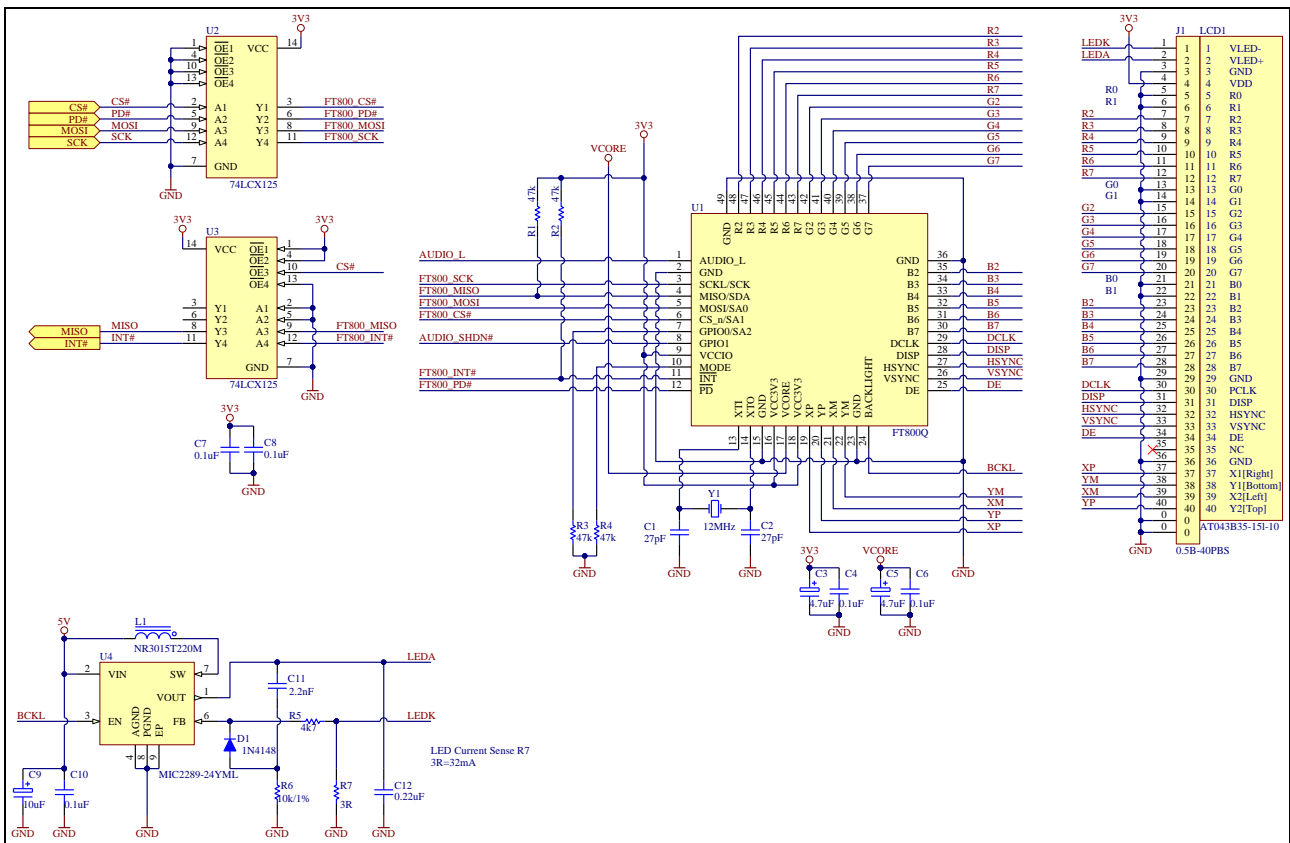

**Figure 4-2 - VM800B43A/VM800B50A (4.3"/5.0" Version)**

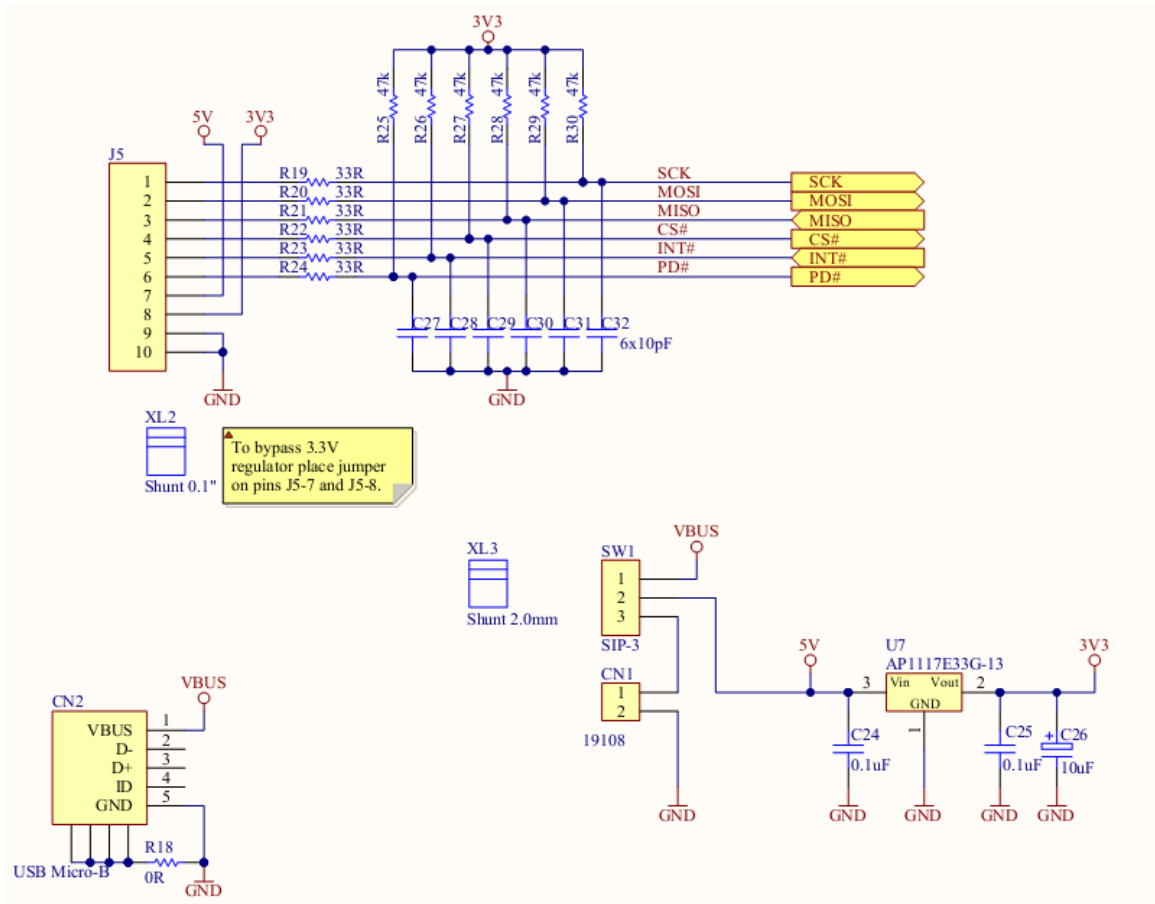

**Figure 4-3 – VM800B SPI Interface and IO**

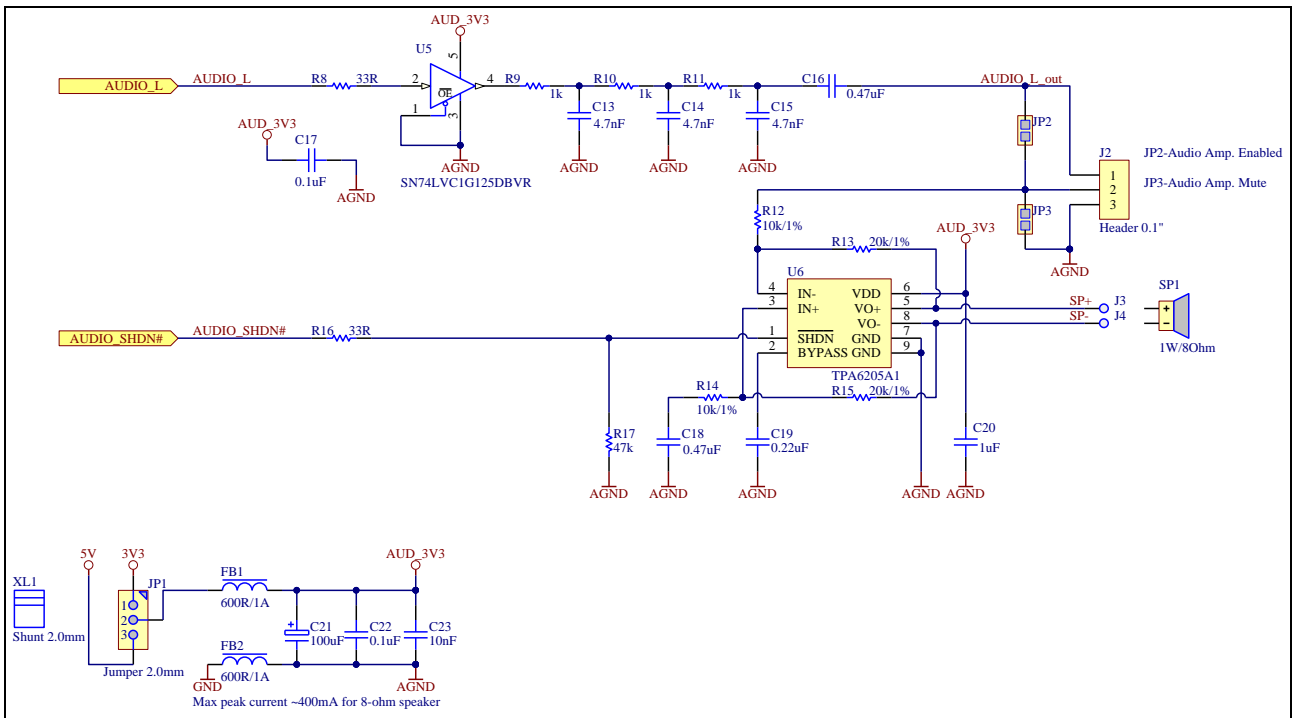

**Figure 4-4 – VM800B Audio**

## 5 Hardware Setup Guide

### 5.1 Power Configuration

There are 5 methods of powering the VM800B board.

- 1) USB Power(5V) - Connect USB power through micro-USB cable to CN2
- 2) DC IN(5V) - Connect 5V to CN1
- 3) DC IN(3.3V) - Connect 3.3V to CN1 and short J5 pin 7 and 8
- 4) J5 Power(5V) - Connect 5V to J5 pin 7
- 5) \*J5 Power(3.3V) - Connect 3.3V to J5 pin 7 and 8

\*Warning: Applying 5 V accidentally in this mode may cause permanent damage to the VM800B module.

The following table summarise how to power the VM800B board using the various methods.

Power Method	CN2	CN1	J5 Pin 7	J5 Pin 8	SW1
USB Power	5V	N/C	N/C	N/C	Short pin 2-3
DC IN(5V)	N/C	5V	N/C	N/C	Short pin 1-2
DC IN(3.3V)	N/C	3.3V	SHORT		Short pin 1-2
J5 Power(5V)	N/C	N/C	5V	N/C	Any Position
J5 Power (3.3V)	N/C	N/C	3.3V		Any Position

**Table 5-1 Board power configuration**

### 5.2 MPSSE Setup

To provide a quick start with the VM800B development board, Windows based sample projects including source code are provided for users to get a touch and feel experience with the VM800B. An overview of the process is provided in the following paragraphs with more details in [AN 245 VM800CB SampleAPP PC Introduction](#)

MPSSE is a "multi-purpose synchronous serial engine" interface available in some FTDI devices (e.g. FT2232D, FT232H, FT2232H and FT4232H). This engine allows users to bridge from a USB port on a PC to an I<sup>2</sup>C or SPI interface. Sample code is available for driving the FT800 over this interface with a FT232H device.

VA800A-SPI is a MPSSE module accessory which can connect to the VM800B modules directly. Detailed information of VA800A-SPI can be found at:

<http://www.ftdichip.com/Products/modules/VA800A-SPI.html>

FTDI also provide a multipurpose MPSSE cable assembly C232HM-EDHSL-0(5V) or C232HM-DDHSL-0(3.3V) for rapid setup. More information on the cable may be found at: [http://www.ftdichip.com/Support/Documents/DataSheets/Cables/DS\\_C232HM\\_MPSSE\\_CABLE.pdf](http://www.ftdichip.com/Support/Documents/DataSheets/Cables/DS_C232HM_MPSSE_CABLE.pdf).

In this section it is assumed the VA800A-SPI is used. VA800A-SPI supplies 5 V for VM800B modules. If the VM800B is connected to an SPI interface with a 3.3 V power supply, refer to table 5-1 for the board power configuration. Note, improper power supply and/or IO voltage connection may damage the VM800B module.

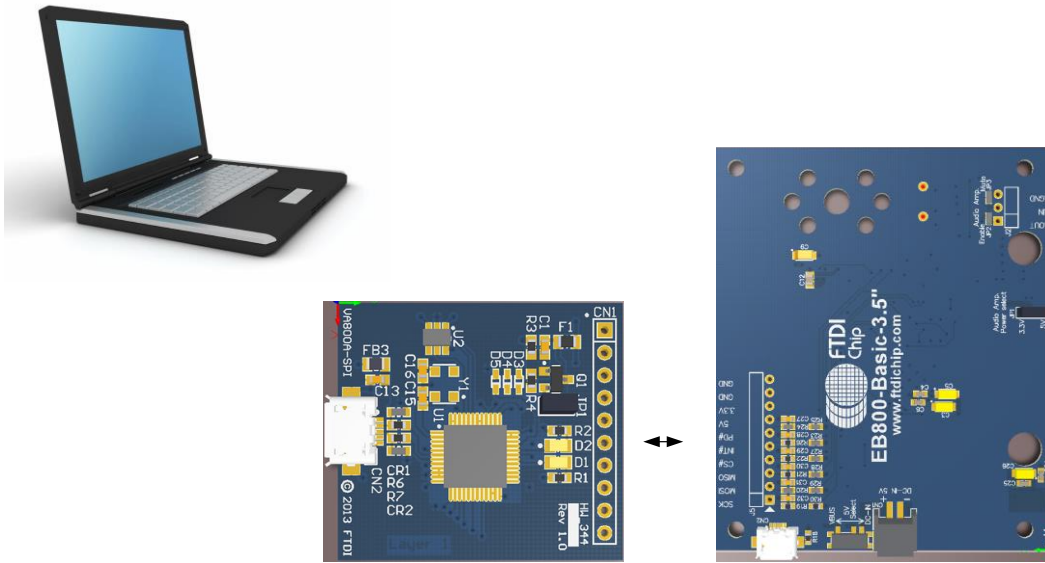

**Figure 5-1 – VM800B connects to PC through VA800A-SPI accessory**

**Hardware Setup**

- Connect the VA800A-SPI to the VM800B module in the correct orientation (with J5-pin1 of VM800B board connected to CN1-pin1 of VA800A-SPI board).
- Connect a USB cable (suggest FTDI accessory **VA-FC-1M-BKW** or **VA-FC-1M-BLW**) from the VA800A-SPI to the PC USB host port or self-powered hub port.
- The VA800A-SPI will supply power to the VM800B after the MPSSE driver is properly loaded and the USB host completes USB device configuration.

NOTE: If using the C232HM-EDHSL-0(5V) MPSSE cable then the connection is as:

J5 Pin number	J5 Signal	MPSSE pin number	MPSSE Signal	MPSSE Cable Lead Colour
1	SCK	2	SK	ORANGE
2	MOSI	3	DO	YELLOW
3	MISO	4	DI	GREEN
4	CS#	5	CS	BROWN
5	INT#	7	GPIOL1	PURPLE
6	PD#	9	GPIOL3	BLUE
7	5V	1	VCC	RED
8	3.3V	-	-	-
9	GND	10	GND	Black
10	GND	-	-	-

**Table 5-2 – MPSSE cable (C232HM-EDHSL-0) connection**

---

**Software Setup**

- The following software setup steps apply to both the VA800A-SPI and MPSSE cable assembly.
- Download the MPSSE software. MPSSE cable and driver information can be found at <http://www.ftdichip.com/Products/Cables/USBMPSSE.htm>.
- Launch the demo application based on MPSSE from the PC

The demo application notes can be found at following link:  
[AN\\_245\\_VM800CB\\_SampleAPP\\_PC\\_Introduction](#)

### 5.3 Arduino® Setup

Sample code and demo applications are provided to users who want to connect the VM800B to a MCU. FTDI provides sample source code, sample application notes and a ready to run demo based on the Arduino® platform. Detailed information can be found at:  
<http://testwebsite/Products/modules/VM800B.html>

## 6 Assembling the Bezel and Panel Mounting

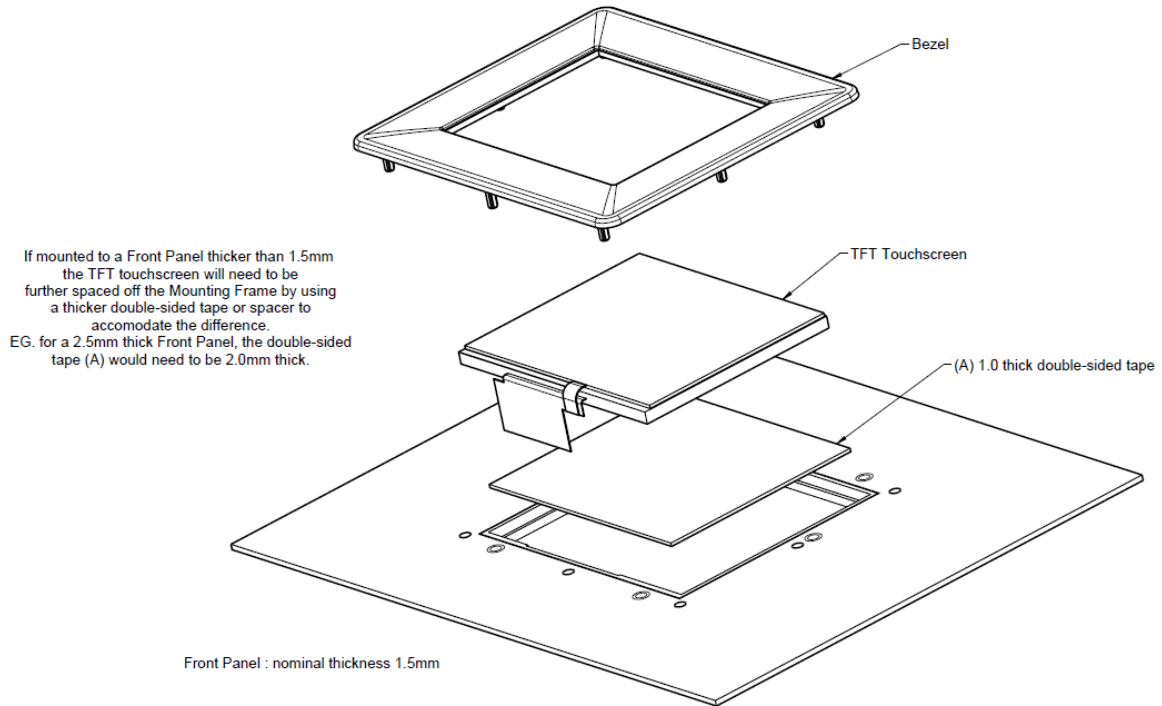

**Figure 6-1 - VM800B Panel Mount (Front view)**

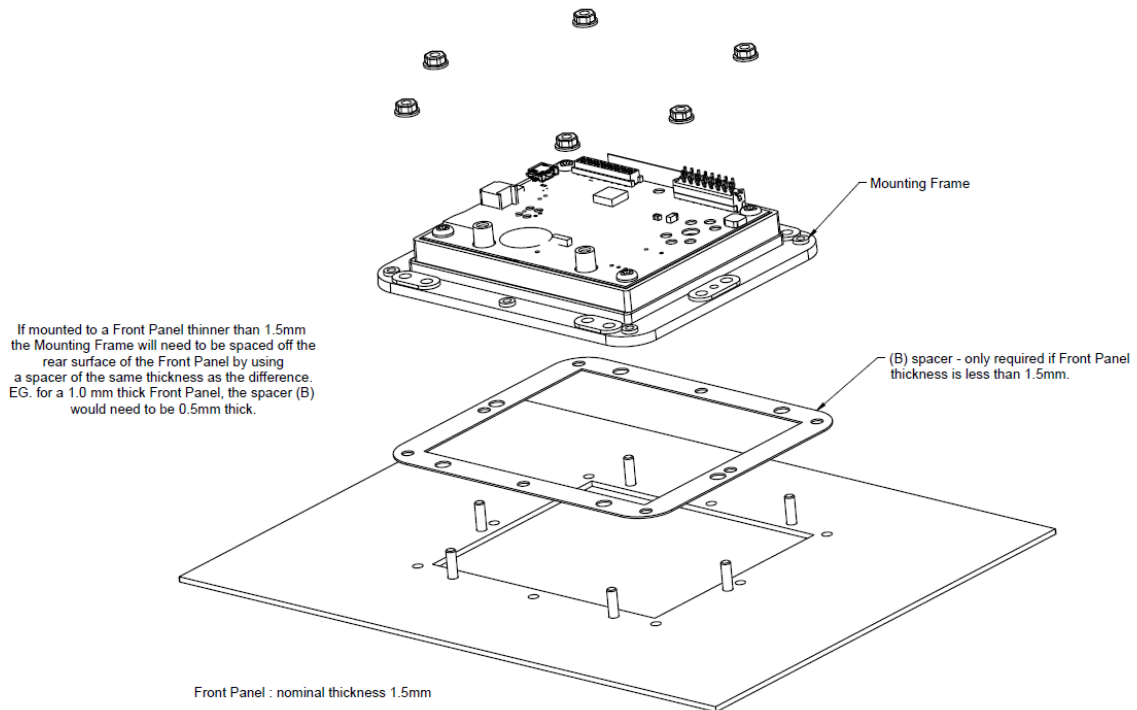

**Figure 6-2 - VM800B Panel Mount (Rear view)**



### 6.1 3.5" Dimensions

The TFT Touchscreen Mounting Frame is designed to mount to a 1.5mm thick Front Panel. If mounted to a Front Panel thicker than 1.5mm, longer mounting studs or screws should be used to accommodate the difference.

The Mounting Frame has been designed to work with projection welded studs or csk screws 'A' or press studs 'B'. For a 1.5mm thick Front Panel use -  
 M3 x 8 long weld studs,  
 M3 x 10 long countersunk screws or  
 M3 x 10 long pressed studs

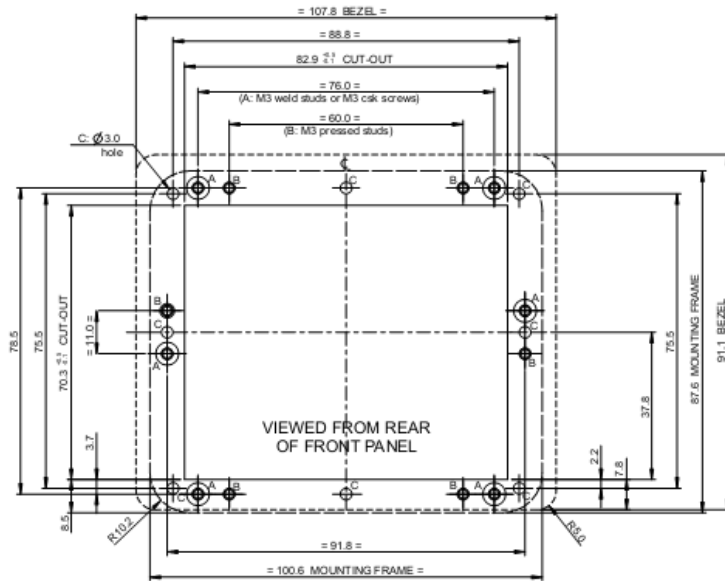

When using countersunk screws to assemble the Mounting Frame, the screws should be located at the 'A' position

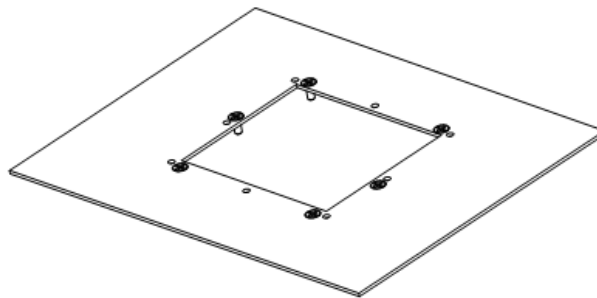
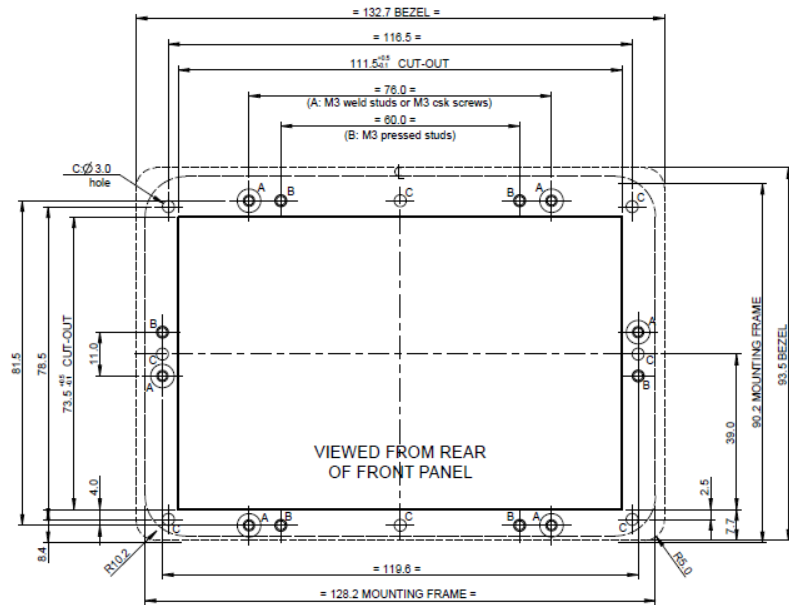

**Figure 6-3 - VM800B 3.5" panel mount dimensions**

## 6.2 4.3" Dimensions

The TFT Touchscreen Mounting Frame is designed to mount to a 1.5mm thick Front Panel. If mounted to a Front Panel thicker than 1.5mm, longer mounting studs or screws should be used to accommodate the difference.

The Mounting Frame has been designed to work with projection welded studs or csk screws 'A' or press studs 'B'. For a 1.5mm thick Front Panel use -  
 M3 x 8 long weld studs,  
 M3 x 10 long countersunk screws or  
 M3 x 10 long pressed studs



When using countersunk screws to assemble the Mounting Frame, the screws should be located at the 'A' position

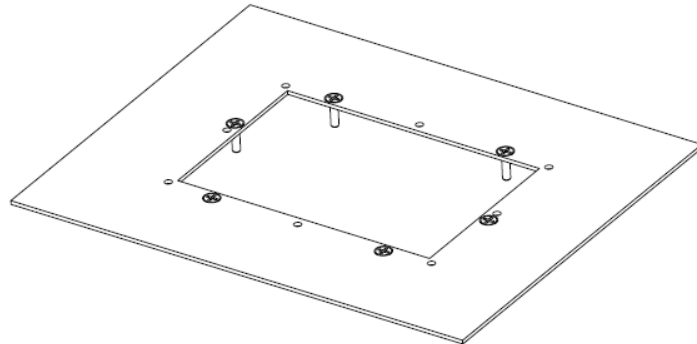

**Figure 6-4 - VM800B 4.3" panel mount dimensions**

### 6.3 5.0" Dimensions

The TFT Touchscreen Mounting Frame is designed to mount to a 1.5mm thick Front Panel. If mounted to a Front Panel thicker than 1.5mm, longer mounting studs or screws should be used to accommodate the difference.

The Mounting Frame has been designed to work with projection welded studs or csk screws 'A' or press studs 'B'. For a 1.5mm thick Front Panel use - M3 x 8 long weld studs, M3 x 10 long countersunk screws or M3 x 10 long pressed studs

When using countersunk screws to assemble the Mounting Frame, the screws should be located at the 'A' position

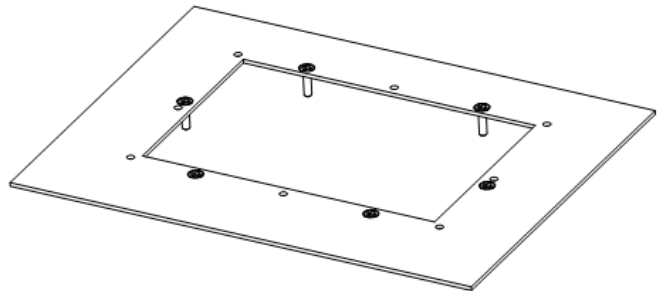
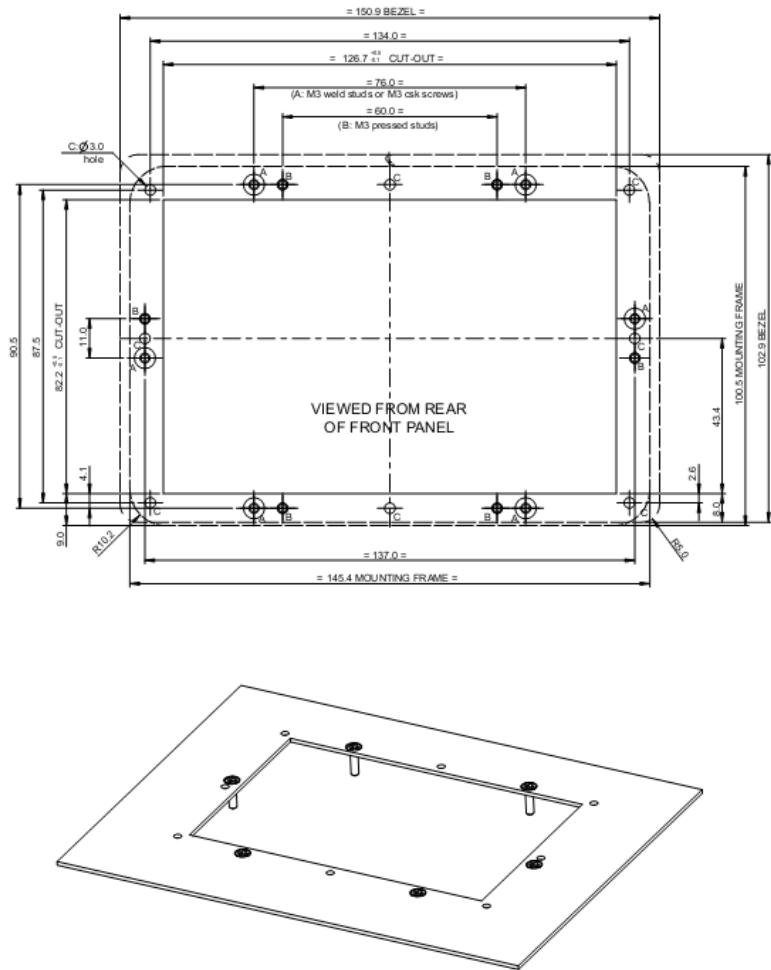

**Figure 6-5 - VM800B 5.0" panel mount dimensions**

## 7 Specifications

### 7.1 Optical Specification

Item	Symbol	Condition	Min	Typ.	Max.	Unit
View Angles	$\theta T$	$CR \geq 10$	30	40		Degree
	$\theta B$		50	60		
	$\theta L$		50	60		
	$\theta R$		50	60		
Contrast Ratio	CR	$\theta = 0^\circ$		350		
Response Time	Ton	25°C		25	40	ms
	Toff					
Chromaticity	White	x	0.260	0.310	0.360	
		y	0.283	0.333	0.383	
	RED	x	0.574	0.624	0.674	
		y	0.318	0.368	0.418	
	GREEN	x	0.300	0.350	0.400	
		y	0.500	0.550	0.600	
	BLUE	x	0.093	0.143	0.193	
		y	0.069	0.119	0.169	
Uniformity	U		75	80		%
NTSC				50		%
Luminance	L			500		cd/m <sup>2</sup>

**Table 7-1 - 3.5" TFT Optical specification**

Item	Symbol	Condition	Min.	Typ.	Max.	Unit
Brightness	Bp	$\theta=0^\circ$	-	350	-	Cd/m <sup>2</sup>
Uniformity	$\Delta Bp$	$\Phi=0^\circ$	70	80	-	%
Viewing Angle	3:00	Cr $\geq$ 10	-	45	-	Deg
	6:00		-	20	-	
	9:00		-	45	-	
	12:00		-	40	-	
Contrast Ratio	Cr	$\theta=0^\circ$ $\Phi=0^\circ$	350	500	-	-
Response Time	T <sub>r</sub>		-	10	-	ms
	T <sub>f</sub>		-	10	-	ms
Color of CIE Coordinate	W	x	$\theta=0^\circ$ $\Phi=0^\circ$	0.28	-	-
		y		0.33	-	-
	R	x		0.51	-	-
		y		0.34	-	-
	G	x		0.31	-	-
		y		0.56	-	-
	B	x		0.15	-	-
		y		0.14	-	-
NTSC Ratio	S	50	60	-	%	

**Table 7-2 - 4.3" TFT Optical Specification**

Item	Symbol	Condition	Min.	Typ.	Max.	Unit
Brightness	Bp	$\theta=0^\circ$	200	250	-	Cd/m <sup>2</sup>
Uniformity	$\Delta$ Bp	$\Phi=0^\circ$	70	80	-	%
Viewing Angle	3:00	Cr $\geq$ 10	-	45	-	Deg
	6:00		-	25	-	
	9:00		-	45	-	
	12:00		-	45	-	
Contrast Ratio	Cr	$\theta=0^\circ$ $\Phi=0^\circ$	350	500		-
Response Time	T <sub>r</sub>		-	10	-	ms
	T <sub>f</sub>		-	10	-	ms
Color of CIE Coordinate	W	x		0.28		-
		y		0.33		-
	R	x		0.51		-
		y		0.34		-
	G	x		0.31		-
		y		0.56		-
	B	x		0.15		-
		y		0.14		-
NTSC Ratio	S		50	60	-	%

**Table 7-3 - 5" TFT Optical Specification**

## 8 Contact Information

### Head Quarters – Singapore

Bridgetek Pte Ltd  
178 Paya Lebar Road, #07-03  
Singapore 409030  
Tel: +65 6547 4827  
Fax: +65 6841 6071

E-mail (Sales) [sales.apac@brtchip.com](mailto:sales.apac@brtchip.com)  
E-mail (Support) [support.apac@brtchip.com](mailto:support.apac@brtchip.com)

### Branch Office – Taipei, Taiwan

Bridgetek Pte Ltd, Taiwan Branch  
2 Floor, No. 516, Sec. 1, Nei Hu Road, Nei Hu District  
Taipei 114  
Taiwan, R.O.C.  
Tel: +886 (2) 8797 5691  
Fax: +886 (2) 8751 9737

E-mail (Sales) [sales.apac@brtchip.com](mailto:sales.apac@brtchip.com)  
E-mail (Support) [support.apac@brtchip.com](mailto:support.apac@brtchip.com)

### Branch Office - Glasgow, United Kingdom

Bridgetek Pte. Ltd.  
Unit 1, 2 Seaward Place, Centurion Business Park  
Glasgow G41 1HH  
United Kingdom  
Tel: +44 (0) 141 429 2777  
Fax: +44 (0) 141 429 2758

E-mail (Sales) [sales.emea@brtchip.com](mailto:sales.emea@brtchip.com)  
E-mail (Support) [support.emea@brtchip.com](mailto:support.emea@brtchip.com)

### Branch Office – Vietnam

Bridgetek VietNam Company Limited  
Lutaco Tower Building, 5th Floor, 173A Nguyen Van  
Troj,  
Ward 11, Phu Nhuan District,  
Ho Chi Minh City, Vietnam  
Tel : 08 38453222  
Fax : 08 38455222

E-mail (Sales) [sales.apac@brtchip.com](mailto:sales.apac@brtchip.com)  
E-mail (Support) [support.apac@brtchip.com](mailto:support.apac@brtchip.com)

### Web Site

<http://brtchip.com/>

### Distributor and Sales Representatives

Please visit the Sales Network page of the [Bridgetek Web site](#) for the contact details of our distributor(s) and sales representative(s) in your country.

System and equipment manufacturers and designers are responsible to ensure that their systems, and any Future Technology Devices International Ltd (FTDI) devices incorporated in their systems, meet all applicable safety, regulatory and system-level performance requirements. All application-related information in this document (including application descriptions, suggested FTDI devices and other materials) is provided for reference only. While FTDI has taken care to assure it is accurate, this information is subject to customer confirmation, and FTDI disclaims all liability for system designs and for any applications assistance provided by FTDI. Use of FTDI devices in life support and/or safety applications is entirely at the user's risk, and the user agrees to defend, indemnify and hold harmless FTDI from any and all damages, claims, suits or expense resulting from such use. This document is subject to change without notice. No freedom to use patents or other intellectual property rights is implied by the publication of this document. Neither the whole nor any part of the information contained in, or the product described in this document, may be adapted or reproduced in any material or electronic form without the prior written consent of the copyright holder. Future Technology Devices International Ltd, Unit 1, 2 Seaward Place, Centurion Business Park, Glasgow G41 1HH, United Kingdom. Scotland Registered Company Number: SC136640

## Appendix A - References

### Document References

For module documentations, please refer to URL below:

<http://testwebsite/Products/modules/VM800B.html>

FT800 datasheet: [DS\\_FT800\\_Embedded\\_Video\\_Engine](#)

FT800 software programming guide: [FT800\\_Programmer\\_Guide](#)

FT800 sample application notes:

[AN\\_245\\_VM800CB\\_SampleAPP\\_PC\\_Introduction](#)

[AN\\_246\\_VM800CB\\_SampleAPP\\_Arduino\\_Introduction](#)

C232HM-EDHSL-0 datasheet:

[http://www.ftdichip.com/Support/Documents/DataSheets/Cables/DS\\_C232HM\\_MPSSE\\_CABLE.pdf](http://www.ftdichip.com/Support/Documents/DataSheets/Cables/DS_C232HM_MPSSE_CABLE.pdf)

D2xx Programmers Guide:

[http://www.ftdichip.com/Support/Documents/ProgramGuides/D2XX\\_Programmer's\\_Guide\(FT\\_000071\).pdf](http://www.ftdichip.com/Support/Documents/ProgramGuides/D2XX_Programmer's_Guide(FT_000071).pdf)

AN\_108: Command Processor for MPSSE and MCU Host Bus Emulation Modes

[http://www.ftdichip.com/Support/Documents/AppNotes/AN\\_108\\_Command\\_Processor\\_for\\_MPSSE\\_and\\_MCU\\_Host\\_Bus\\_Emulation\\_Modes.pdf](http://www.ftdichip.com/Support/Documents/AppNotes/AN_108_Command_Processor_for_MPSSE_and_MCU_Host_Bus_Emulation_Modes.pdf)



## Appendix B - List of Figures and Tables

### List of Figures

Figure 3-1 – VM800B module profile 3.5” display version .....	4
Figure 3-2 - VM800B module profile 4.3” display version .....	4
Figure 3-3 - VM800B module profile 5” display version .....	4
Figure 3-4 - VM800B module PCB view, 3.5 inch display version .....	5
Figure 3-5 - VM800B module PCB view, 4.3 and 5 inch display version .....	6
Figure 4-1 - VM800B35A (3.5” Version) .....	9
Figure 4-2 - VM800B43A/VM800B50A (4.3”/5.0” Version).....	10
Figure 4-3 – VM800B SPI Interface and IO .....	11
Figure 4-4 – VM800B Audio.....	12
Figure 5-1 – VM800B connects to PC through VA800A-SPI accessory .....	14
Figure 6-1 - VM800B Panel Mount (Front view).....	16
Figure 6-2 - VM800B Panel Mount (Rear view).....	16
Figure 6-3 - VM800B 3.5” panel mount dimensions .....	17
Figure 6-4 - VM800B 4.3” panel mount dimensions .....	18
Figure 6-5 - VM800B 5.0” panel mount dimensions .....	19

### List of Tables

Table 2-1 – Ordering information .....	2
Table 3-1 – CN1 Pinout.....	6
Table 3-2 – CN2 Pinout.....	6
Table 3-3 – J2 Pin Options .....	7
Table 3-4 – J5 Pinout .....	7
Table 3-5 – JP1 Pin options .....	7
Table 3-6 – SW1 jumper options .....	8
Table 5-1 Board power configuration .....	13
Table 5-2 – MPSSE cable (C232HM-EDHSL-0) connection .....	14
Table 7-1 - 3.5” TFT Optical specification .....	20
Table 7-2 - 4.3” TFT Optical Specification .....	21
Table 7-3 - 5” TFT Optical Specification .....	22

## Appendix C – Revision History

Document Title: VM800B Datasheet  
Document Reference No.: BRT\_000004  
Clearance No.: BRT #006  
Product Page: <http://brtchip.com/product>  
Document Feedback: [Send Feedback](#)

Revision	Changes	Date
Version 1.0	Initial Release	2013-08-28
Version 1.1	Corrected dimensions for 4.3" mounting in section 6.2	2014-03-25
Version 1.2	Updated the optical characteristics for the 4.3" and 5" displays	2014-06-12
Version 1.3	Dual branding to reflect the migration of the product to the Bridgetek name – logo changed, copyright changed, contact information changed	2016-09-13