

PRODUCT NUMBER  
20020110-XXXXXXLF

# 20020110-XXXXXXLF



PITCH



- C: 3.50 mm
- D: 3.81 mm
- G: 5.00 mm
- H: 5.08 mm

POLES

- 02: 2 POLES
  - 03: 3 POLES
  - 04: 4 POLES
- 
- 24: 24 POLES

LF : DENOTED RoHS COMPATIBLE

1 : STANDARD PRODUCT  
W/ BOX PACKING

PROPERTY TABLE	
FCI SERIES NAME	06-350 06-381 06-500 06-508
PITCH (mm)	3.50 3.81 5.00 5.08
VOLTAGE RATING (VAC)	300 300 300 300
CURRENT RATING (A)	cULus 10 10 12 12
	VDE 10.5 10.5 NA NA
WITHSTANDING VOLTAGE (kV)	cULus 1.6 1.6 1.6 1.6
	VDE 2.5 2.5 NA NA
OPERATING TEMP. (°C)	-40~+115 -40~+115 -40~+115 -40~+115
SOLDERING TEMP. (°C)	250±10 250±10 250±10 250±10
	(5 sec.) (5 sec.) (5 sec.) (5 sec.)
POLES AVAILABLE	02~24 02~24 02~24 02~24
SAFETY CERTIFICATE	  

HOUSING CODE

CODE	COLOR	AVAILABILITY
1	GREEN(RAL 6018/T)	STANDARD
2	BLACK	ON REQUEST ONLY
3	GREY(RAL 7004/P)	ON REQUEST ONLY
4	BLUE(RAL 5015/A)	ON REQUEST ONLY

NOTES:

MATERIALS

- 1-1 HOUSING: THERMALPLASTIC RESIN, UL 94V-0 RATED.
- 1-2 TERMINAL: COPPER ALLOY, TIN PLATED.
2. PRODUCTION SPECIFICATION REFER TO FCI GS-12-625.
3. BOXED PACKAGING.  
DETAILED PRODUCT PACKING SPECIFICATION REFER TO FCI GS-14-1394.
4. FCI, SAFETY CERTIFICATE LOGO AND SERIES NAME TO BE SHOWN ON PRODUCT SURFACE.
5. THE PRODUCTS WHERE THE PART NUMBER END IN "LF" MEET THE EUROPEAN UNION DIRECTIVE AND OTHER COUNTRY REGULATIONS AS DESCRIBED IN GS-22-008.
6. RECOMMENDED SOLDERING PROCESS BY WAVE SOLDER.

mat'l. code		surface	tolerance	projection	product family	TERMINAL BLOCK
ltr	ecn no	dr	date	tolerances unless otherwise specified	title	
H	T10-0193	WL	122310	X:±0.5[.020]	TERMINAL BLOCK	
J	T11-0013	WL	040811	X.X±0.3[.012]	PLUGGABLE SOCKET, RIGHT ANGLE	
K	T-004746	WL	072011	X.XX±0.1[.004]	dwg no	sheet 1 of 5 size
		dr			20020110	A4
		enfr				
		chr				
		apppd				
sheet	revision	K	K	K		CUSTOMER Drawing
index	sheet	1	2	3	4	5



PRODUCT NUMBER	SERIES NAME	PITCH
20020110-CXXXXXXLF	06-350	3.50 mm

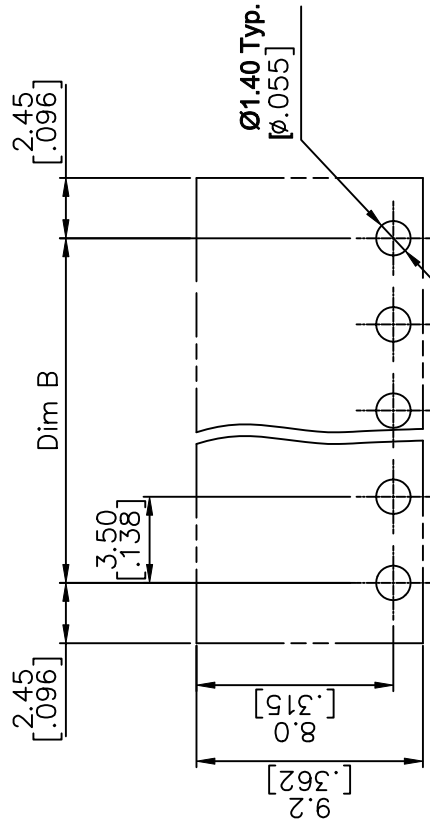
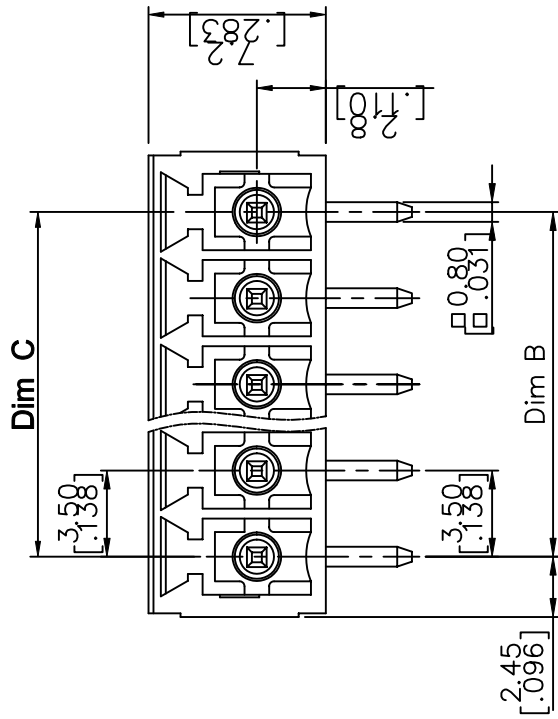

RECOMMENDED P.C.B LAYOUT

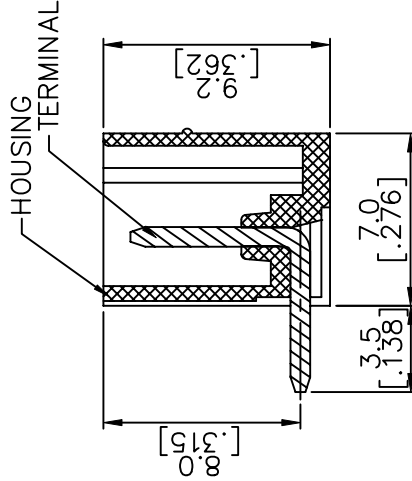
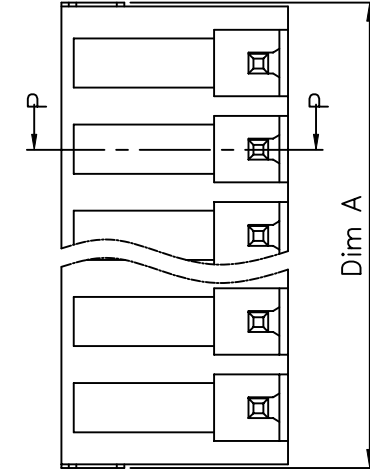

N= NUMBER OF POLES  
DIMENSION

Dim A	(N-1)*3.5[.138]+4.9[.193]
Dim B	(N-1)*3.5[.138]
Dim C	(N-1)*3.5[.138]

Poles	Tolerance
2P-6P	±0.15[.006]
7P-12P	±0.20[.008]
13P-18P	±0.25[.010]
19P-24P	±0.30[.012]

SECTION P-P

mat'l. code		surface	tolerance	projection	product family	TERMINAL BLOCK
itr		ASME Y14.5	ASME Y14.5	MM	terminal block	
ecn no		tolerances unless otherwise specified		INCH	TERMINAL BLOCK	
dr		angles	X.±0.5[.020]	scale	PLUGABLE, SOCKET, SIGNAL, R/A	
date		X.XX±0.3[.012]	X.XX±0.1[.004]		dwg no	sheet 2 of 5
		X'±1'			20020110	A4
		dr	BEER FU		type	CUSTOMER Drawing
		engr	BEER FU			
		chr	GARY HSIEH			
		appd	JOSEPH HSIA			
sheet	revision					
index	sheet					

PRODUCT NUMBER	SERIES NAME	PITCH
20020110-DXXXXXXLF	06-381	3.81 mm

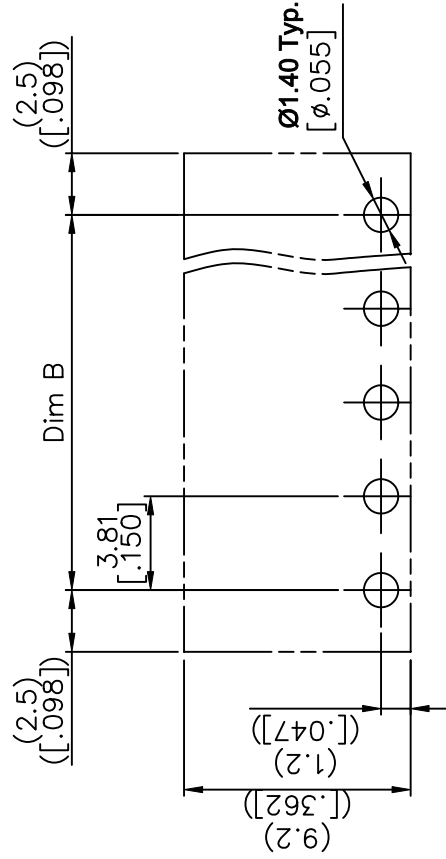
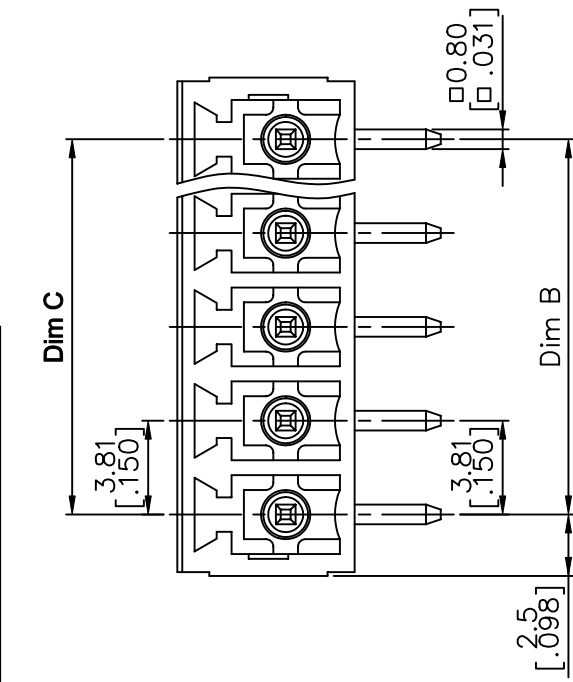

RECOMMENDED P.C.B LAYOUT

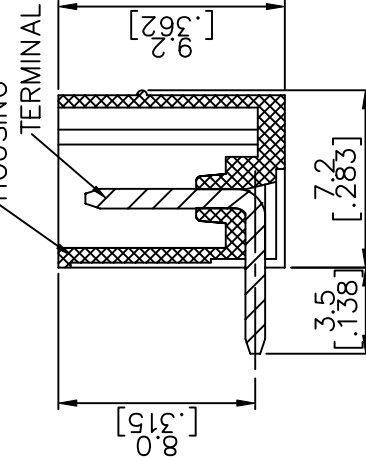
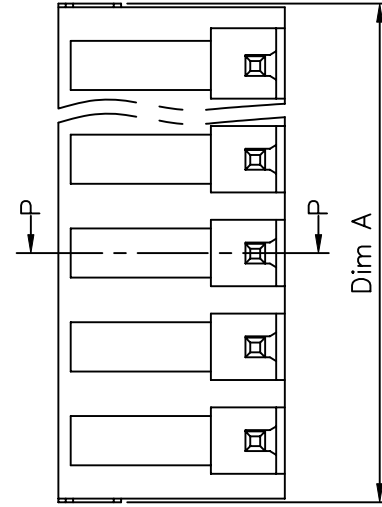

N= NUMBER OF POLES  
DIMENSION

Dim A	(N-1)*3.81 [.150]+5.0 [.197]
Dim B	(N-1)*3.81 [.150]
Dim C	(N-1)*3.81 [.150]

Poles	Tolerance
2p-6p	±0.15 [.006]
7p-12p	±0.20 [.008]
13p-16p	±0.25 [.010]
17p-24p	±0.30 [.012]

SECTION P-P

mat'l. code	surface	tolerance	projection	product family	TERMINAL BLOCK
itr	ASME Y14.5	ASME Y14.5	MM	terminal block	
ecn no	tolerances unless otherwise specified	X.±0.5 [.020]	INCH	terminal block	
dr	angles	X.X±0.3 [.012]	scale	PLUGABLE, SOCKET, SIGNAL, R/A	
date	X*±1*	X.XX±0.1 [.004]		dwg no	sheet 3 of 5
	dr	BEER FU		20020110	A4
	engr	BEER FU			
	chr	GARY HSIEH			
	appd	JOSEPH HSIA			
sheet	revision				
index	sheet				

PRODUCT NUMBER	SERIES NAME	PITCH
20020110-GXXXXXXLF	06-500	5.00 mm

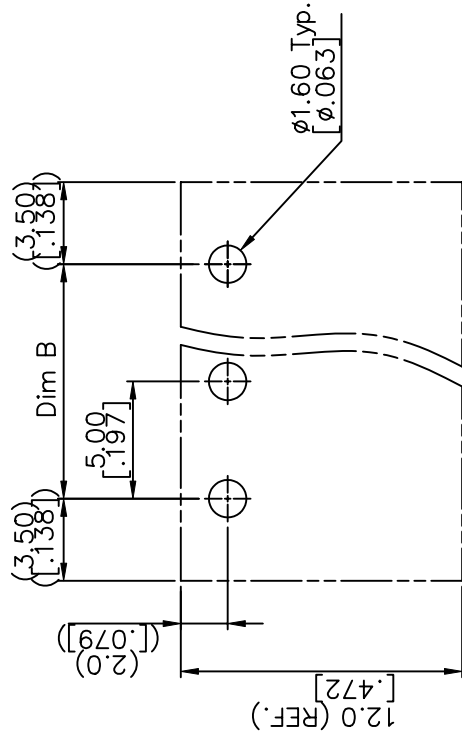
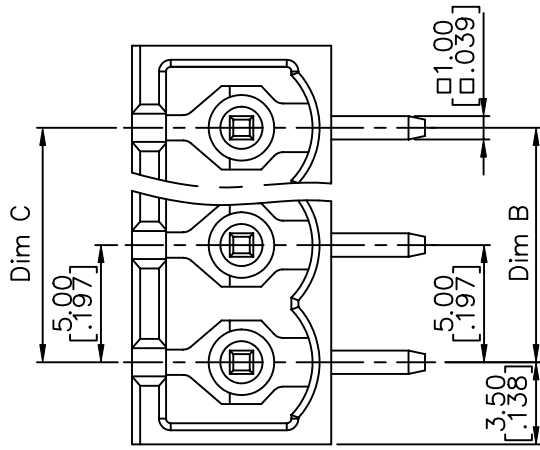

RECOMMENDED P.C.B LAYOUT

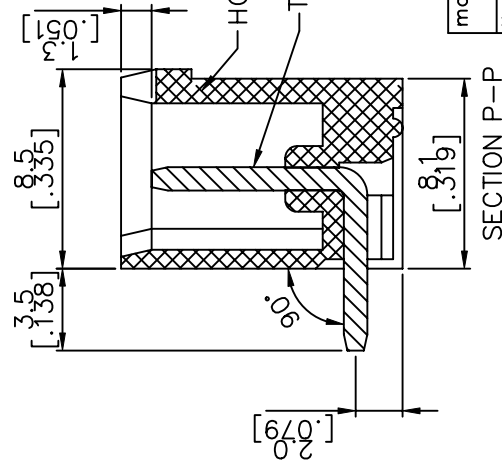
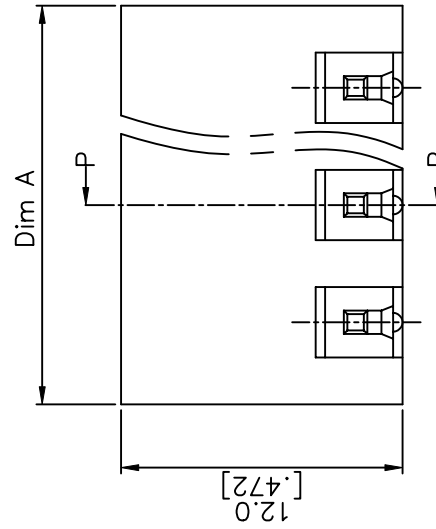

N = NUMBER OF POLES  
DIMENSION

Dim A	$N * 5.0 [ .197 ] + 2.0 [ .193 ]$
Dim B	$(N - 1) * 5.0 [ .197 ]$
Dim C	$(N - 1) * 5.0 [ .197 ]$

Poles	Tolerance
2p-6p	$\pm 0.15 [ .006 ]$
7p-12p	$\pm 0.25 [ .010 ]$
13p-16p	$\pm 0.35 [ .014 ]$
17p-24p	$\pm 0.40 [ .016 ]$

mat'l. code		surface	tolerance	projection	product family	TERMINAL BLOCK
itr	ecn no	ASME Y14.5	ASME Y14.5		title	TERMINAL BLOCK
K	date	tolerances unless otherwise specified	X:±0.5 [.020]	MM	TERMINAL BLOCK PLUGABLE, SOCKET, SIGNAL, R/A	
		angles	X.XX±0.3 [.012]	[INCH]	dwg no	sheet 4 of 5
		X'±1'	X.XX±0.1 [.004]	scale	20020110	A4
		dr	BEER FU 062509		type	CUSTOMER Drawing
		engr	BEER FU 062509			
		chr	GARY HSIEH 062509			
		appd	JOSEPH HSIA 062509			
sheet	revision					
index	sheet					



FCIconnect.com

Copyright FCI.

1 | 2

3 |

4

PRODUCT NUMBER	SERIES NAME	PITCH
20020110-HXXXXXXLF	06-508	5.08 mm

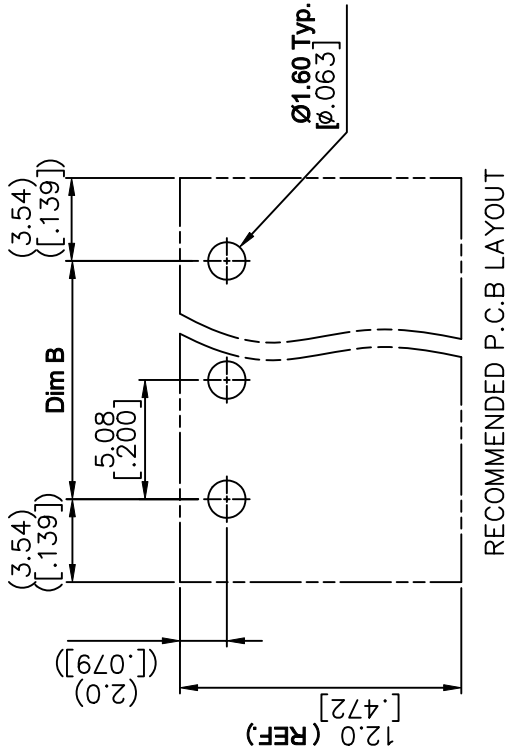
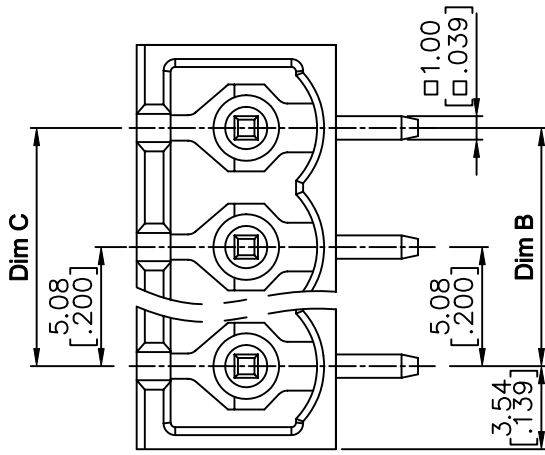

RECOMMENDED P.C.B LAYOUT

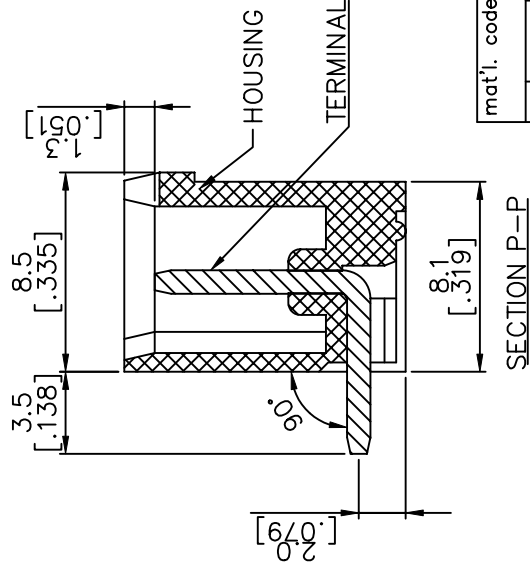
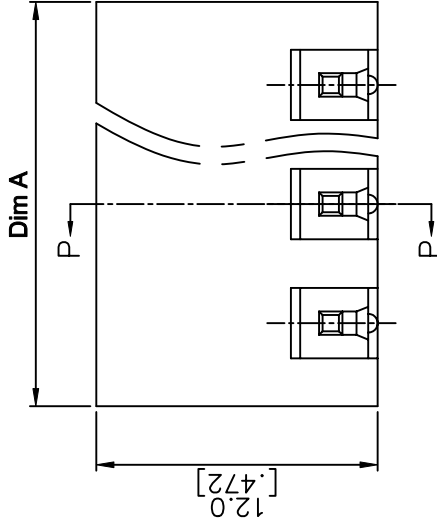

N = NUMBER OF POLES  
DIMENSION

Dim A	$N * 5.08 [ .200 ] + 2.0 [ .193 ]$
Dim B	$(N - 1) * 5.08 [ .200 ]$
Dim C	$(N - 1) * 5.08 [ .200 ]$

Poles	Tolerance
2p-6p	$\pm 0.15 [ .006 ]$
7p-12p	$\pm 0.25 [ .010 ]$
13p-16p	$\pm 0.35 [ .014 ]$
17p-24p	$\pm 0.40 [ .016 ]$

mat'l. code		surface	tolerance	projection	product family	TERMINAL BLOCK
itr	ecn no	ASME Y14.5	ASME Y14.5		title	TERMINAL BLOCK
K	date	tolerances unless otherwise specified	X.X±0.5 [.020]	MM	TERMINAL BLOCK	PLUGABLE, SOCKET, SIGNAL, R/A
		angles	X.XX±0.3 [.012]	[INCH]	dwg no	sheet 5 of 5 size
		X±1°	X.XX±0.1 [.004]	scale	20020110	A4
		dr	BEER FU 062509		type	CUSTOMER Drawing
		engr	BEER FU 062509			
		chr	GARY HSIEH 062509			
		appd	JOSEPH HSIA 062509			
sheet	revision					
index	sheet					