



LIGITEK ELECTRONICS CO.,LTD.
Property of Ligitek Only

LED SMD



LG-110FRGB-T12-A01

DATA SHEET

DOC. NO : QW0905-LG-110FRGB-T12-A01

REV. : A

DATE : 27 - May. - 2019



Features:

1. Meet RoHS.
- 2.Full Color SMD Chip LED With IC Control.
- 3.Sideview Package in 8.0mm carrier tape on 7" diameter reel.
- 4.Each RGB chip is 8 bit control, total of 16M color can be displayed.

Descriptions:

1. The LG-110F SMD product is much smaller than PLCC type components, thus enable smaller board size, higher packing density, reduced storage space and finally smaller equipment to be obtained.
2. Besides, lightweight makes them ideal for miniature applications. etc.

Applications:

1. Consumer product, Home appliances, Telecommunication, light bar.
2. Toy lights, Christmas lights, Decorative lights.

Device Selection Guide:

PART NO	MATERIAL	COLOR	
		Emitted	Lens
LG-110FRGB-T12-A01	AlGaInP	Red	White Diffused
	InGaN	Blue	
	InGaN	Green	

Package Dimensions

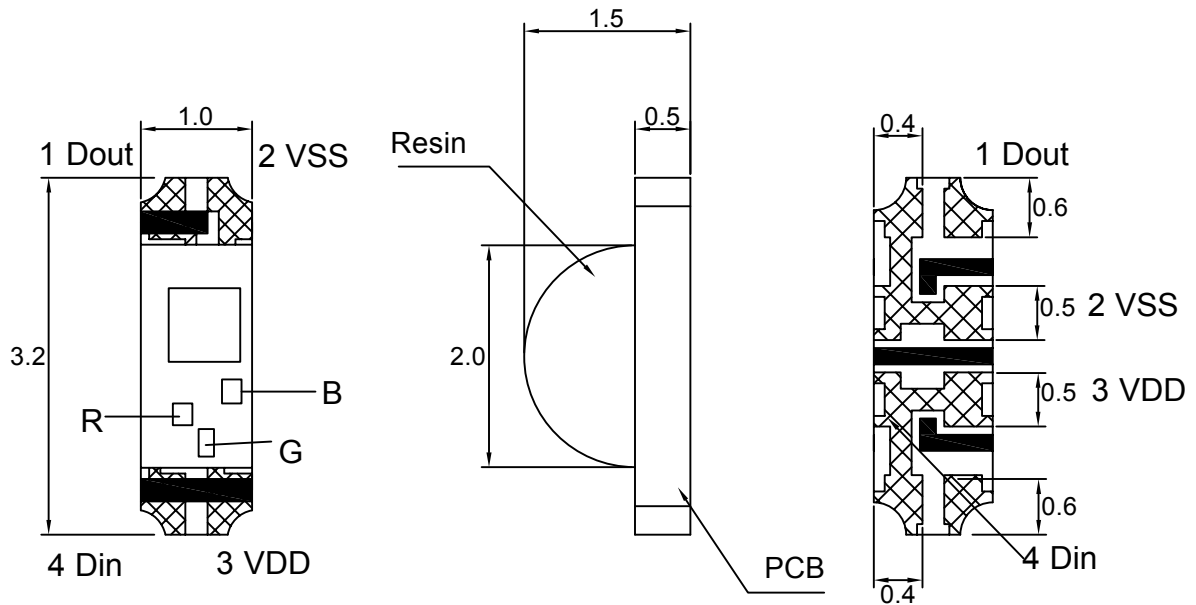

NO.	Symbol	Function Description
1	DOUT	Control date signal output
2	VSS	Ground
3	VDD	DC power input
4	DIN	Control date signal input

Note : 1.All dimension are in millimeter tolerance is $\pm 0.1\text{mm}$ unless otherwise noted.
2.Specifications are subject to change without notice.

Recommended Soldering Pad Dimensions

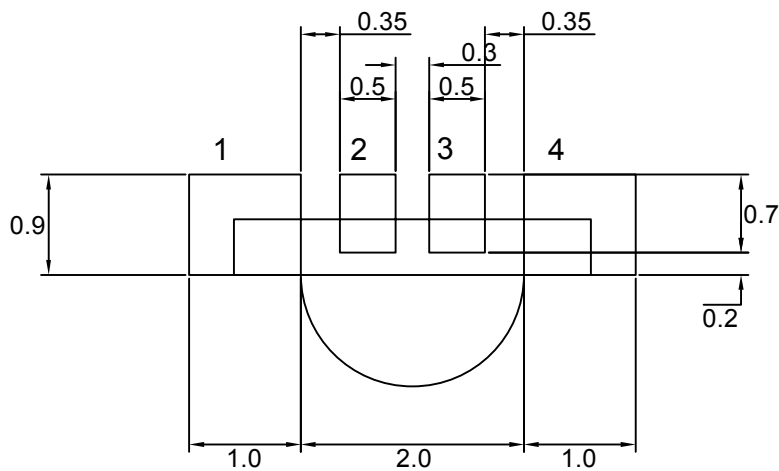

Note : The tolerances unless mentioned is $\pm 0.1\text{mm}$, Angle ± 0.5 . Unit=mm.

Absolute Maximum Ratings

(Ta=25°C, VDD=5V, VSS=0)

Parameter	Symbol	Ratings	UNIT
Supply Voltage	VDD	-0 ~ +6.0	V
LED Output Current	I _{OUT}	25	mA
Operating Temperature	T _{opr}	-40~ +85	°C
Storage Temperature	T _{stg}	-40 ~ +100	°C
Power Dissipation	P _d	400	mW

Typical Electrical & Optical Characteristics (Ta=25°C)

Items	Symbol	Min.	Typ.	Max.	UNIT	CONDITION
Supply Voltage	VDD	3.3	5	5.5	V	
Each R/G/B Current	I _{OL}		12		mA	VDD=5V
Input High Voltage	V _{IH}	2.7		VDD	V	D _I ,
Input Low Voltage	V _{IL}	0		1.0	V	D _I ,
Output High Voltage	V _{OH}	4.5				I _{OH} =4mA
Output Low Voltage	V _{OL}			0.4 VDD	V	I _{OL} =4mA
Operation Current	I _{DD}			2	mA	B、G、R no load
Pull Down Resistance	R _{PD}		500K		Ω	D _{in} , D _{out} (VDD=5V)

Timing Wave Form

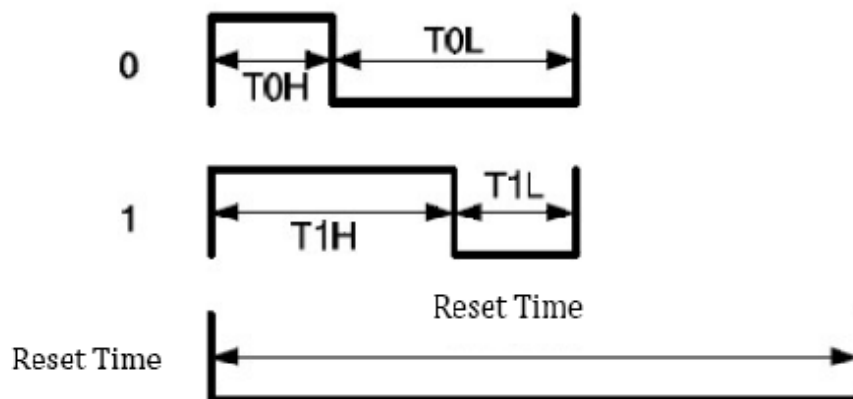

High Speed mode

Item	Description	min	Typical	Allowance	unit
T0H	0 code, High-level time		0.3	± 0.15	us
T0L	0 code, Low-level time		0.9	± 0.15	us
T1H	1 code, High-level time		0.9	± 0.15	us
T1L	1 code, Low-level time		0.3	± 0.15	us
Trst	Reset code, Low-level time	250			

Data Communication

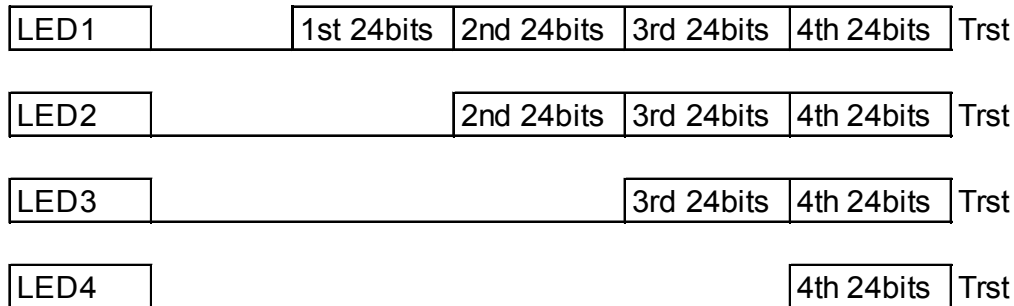

Single Data in 24bit for RGB

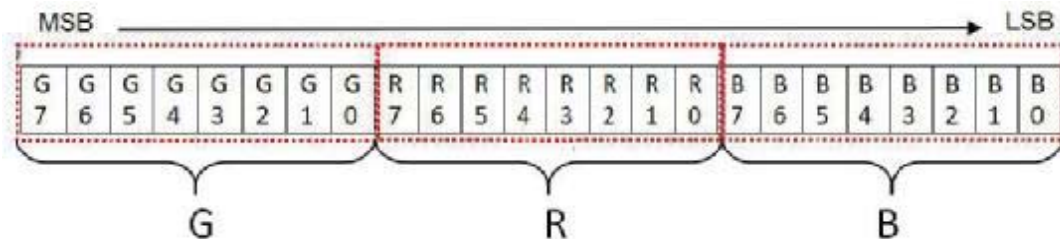

Advance Function Mode

This product has a Advance Function mode that supports the MCU to start with a specific command setting.

Advance Function Mode includes the following function ◦

1. Feedback the cascaded number of LEDs and maximum sink current of R/G/B channel
2. Current Gain control:32 level(5bits) to adjust maximum sink current of R/G/B channel
3. Programmable PWM refresh rate (1.25kHz/2.5kHz/5kHz/10kHz)

Electrical Optical Characteristics at Ta=25°C

Items	Symbol	Min.	Typ.	Max.	UNIT	CONDITION
Luminous Intensity	R	----	282	----	mcd	VDD = 5.0 V
	G	----	364	----		
	B	----	73	----		
Dominant Wavelength	R	----	622	----	nm	
	G	----	530	----		
	B	----	470	----		
Viewing Angle	2θ 1/2	120		deg		

- 1.The luminous intensity data did not including ±15% testing tolerance.
- 2.The dominant wavelength data did not including ±1nm testing tolerance

Typical Electro-Optical Characteristics Curve

Fig.1 R CHIP
Relative Intensity vs. Wavelength

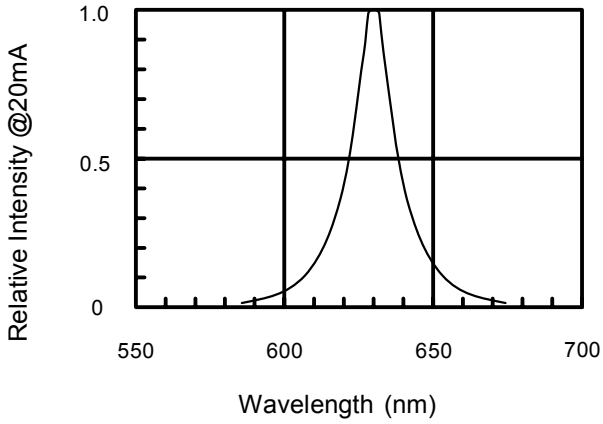

Fig.2 G CHIP
Relative Intensity vs. Wavelength

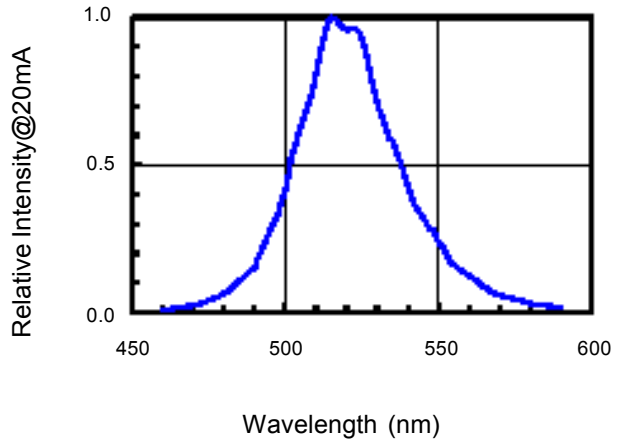

Fig.3 B CHIP
Relative Intensity vs. Wavelength

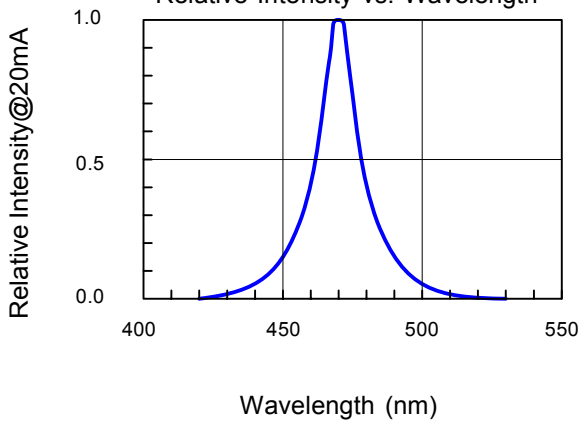
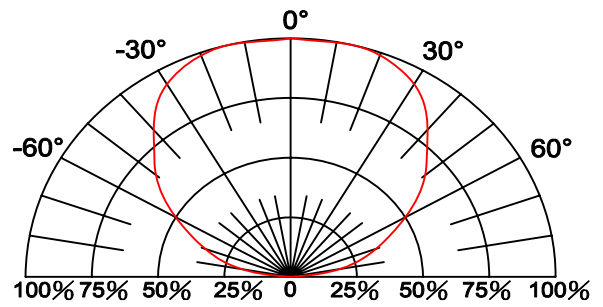
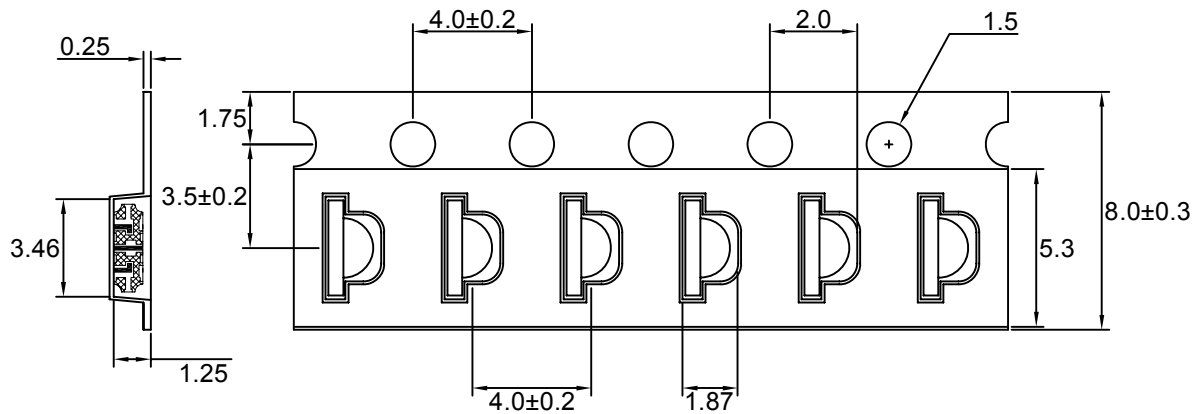

Fig.4 Directive Radiation



Carrier Type Dimensions



Note : The tolerances unless mentioned is ± 0.1 mm, Angle ± 0.5 . Unit=mm.

Packing Specifications

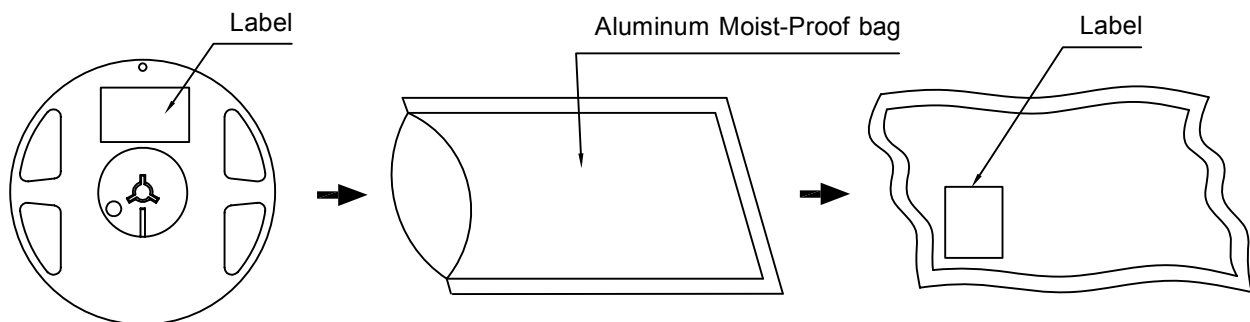

Part No.	Description	Quantity/Reel
LG-110FRGB-T12-A01	8.0mm tape,7"reel	3000 devices

Label Explanation

	LIGITEK ELECTRONICS CO., LTD.
PART :	LG-110FRGB-T12-A01
LOT :	GS11730168
QTY(PCS):	3000
BIN/HUE :	XXXXX

BIN : Luminous Intensity

Reel Dimensions

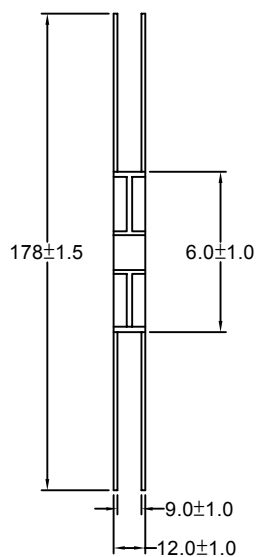
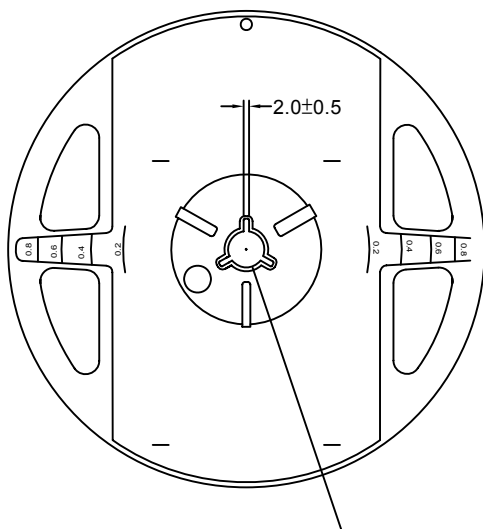

Box Explanation

1. 5 BAG / INNER BOX
2. INNER BOX SIZE : L X W X H 23cm X 8.5cm x 26cm

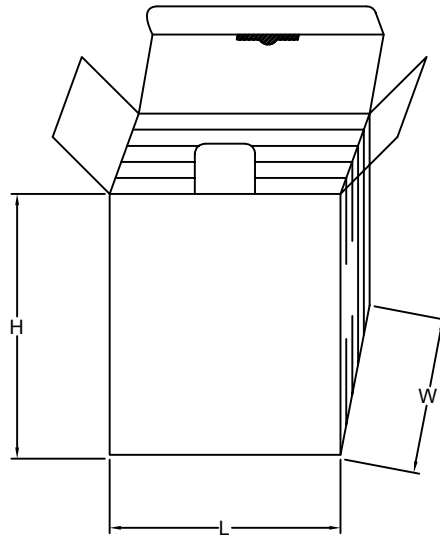

3. 10 INNER BOXES / CARTON
4. CARTON SIZE : L X W X H 58cm X 34cm x 35cm

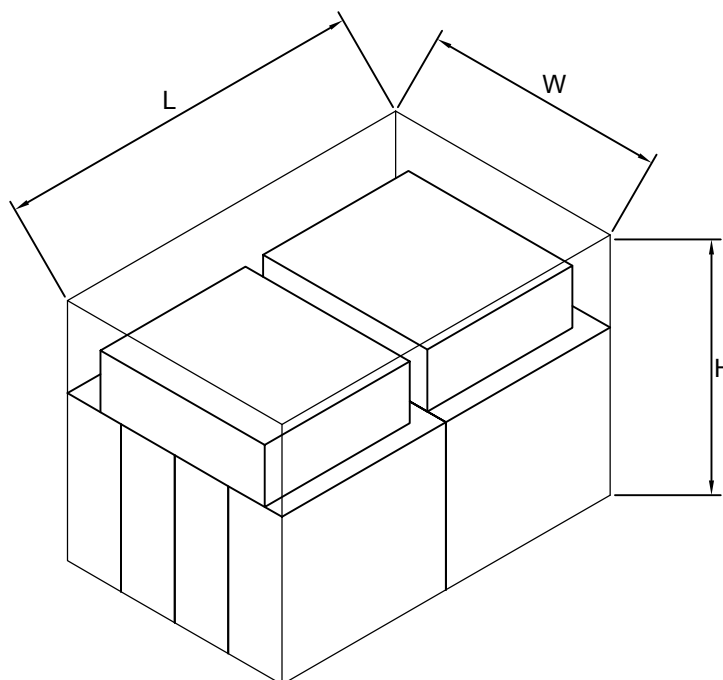

Recommended Soldering Conditions

1. Hand Solder

Basic spec is $\leq 280^{\circ}\text{C}$ 3 sec one time only.

2. PB-Free Reflow Solder

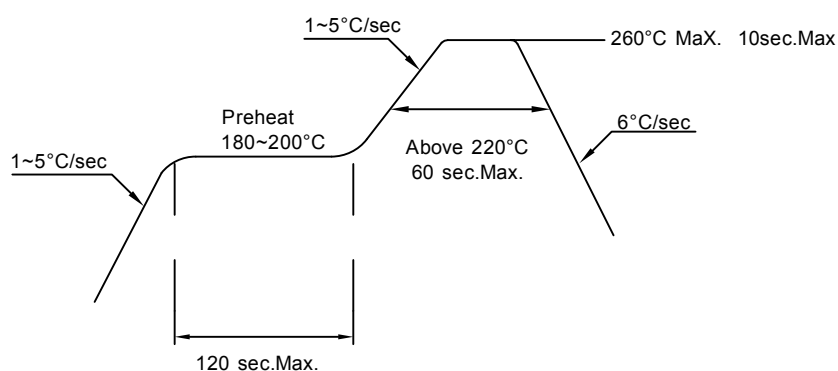

Note:

- 1.Reflow soldering should not be done more than two times.
- 2.When soldering,do not put stress on the LEDs during heating.
- 3.After soldering,do not warp the circuit board.

Precautions For Use:**Storage time:**

1. Calculated shelf life before opening is 12 months at $< 30^{\circ}\text{C}$ and $< 90\%$ relative humidity (RH)
2. After bag is opened, devices which will be subjected to reflow soldering or other high temperature processes must be
 - a) Assembled within 168 hours in an environment of $\leq 30^{\circ}\text{C} / 60\%$ RH, or
 - b) Stored at ambient of 10% RH or less
3. Devices are required baking before assembly if:
 - a) Humidity Indicator Card reads $>10\%$ (for level 2a -5a) or $>60\%$ (for level 2) at ambient temperature $23\pm 5^{\circ}\text{C}$
 - b) 2.a) or 2.b) doesn't meet
4. If baking is required, devices should be baked for >24 hours at $60\pm 5^{\circ}\text{C} / 5\%$ RH. Performing baking only once, and using the baked devices within 8 hours.

Drive Method:

LED is a current operated device, and therefore, requires some kind of current limiting incorporated into the driver circuit. This current limiting typically takes the form of a current limiting resistor placed in series with the LED.

Consider worst case voltage variations than could occur across the current limiting resistor. The forward current should not be allowed to change by more than 40% of its desired value.

Circuit model A

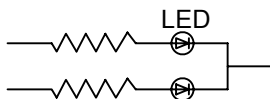

Circuit model B

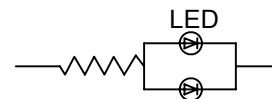

(A) Recommended circuit.

(B) The difference of brightness between LED could be found due to the VF-IF characteristics of LED.

Cleaning:

Use alcohol-based cleaning solvents such as isopropyl alcohol to clean the LED.

ESD(Electrostatic Discharge):

Static Electricity or power surge will damage the LED. Use of a conductive wrist band or anti-electrostatic glove is recommended when handling these LED. All devices, equipment and machinery must be properly grounded.