

REVISION RECORD				
REV	ECN	DESCRIPTION	DRFT	DATE

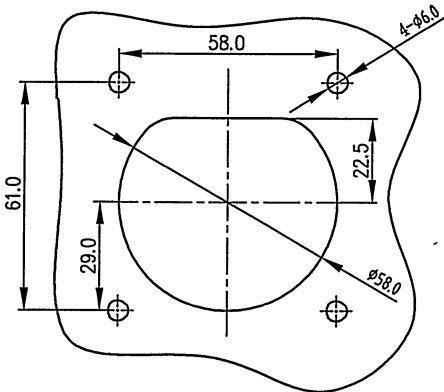
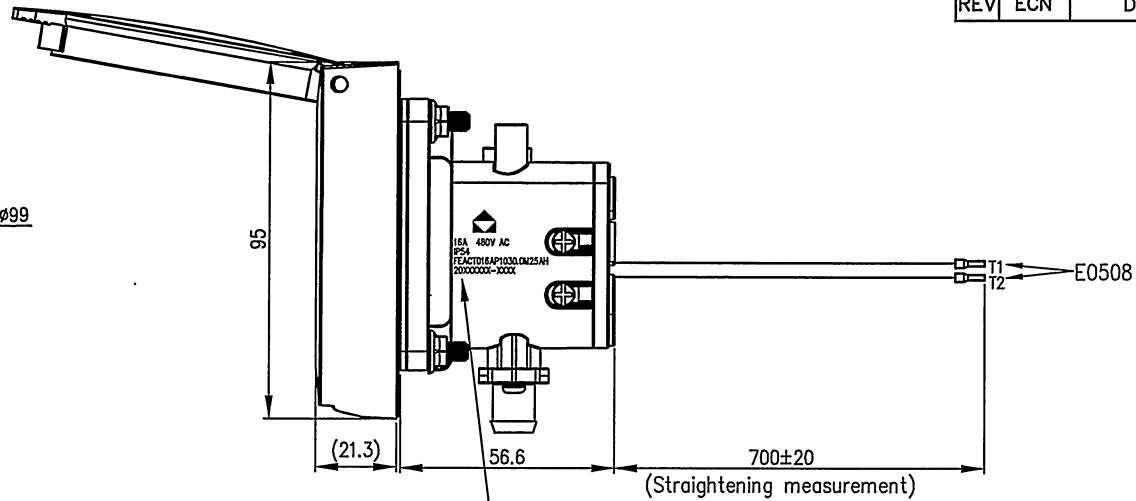
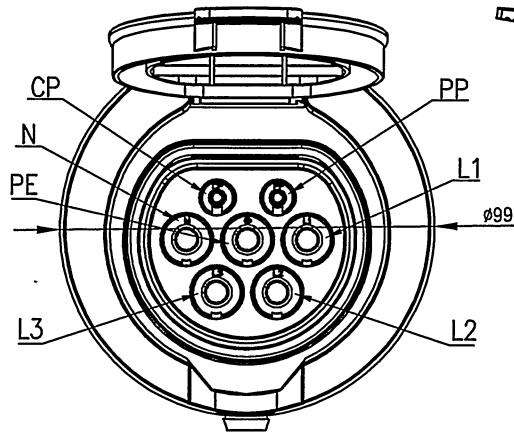

Installation plate dimension

Technical data	
Rated voltage	480V AC
Rated current	16A
Temperature range	-30℃~+50℃
Insulate resistance	>5MΩ,500V DC 1min
Withstanding Voltage	L、N and PE 2500V AC 1min L and N 2500V AC 1min
Ingress protection rating	IP54
Mechanical Working Life (Mating Cycles)	10,000 Times
Standartd	IEC 62196-2: 2016
Flame Class	UL 94V-0

Connection Mode:

L1	(2.5mm <sup>2</sup> )	L1
L2	(2.5mm <sup>2</sup> )	L2
L3	(2.5mm <sup>2</sup> )	L3
N	(2.5mm <sup>2</sup> )	N
PE	(2.5mm <sup>2</sup> )	PE
PP	(0.75mm <sup>2</sup> )	PP
CP	(0.75mm <sup>2</sup> )	CP
NTC	White	T1
	White	T2

Laser Printing:

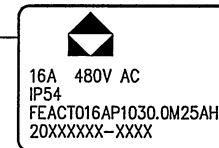

Temperature sensor clip hole for NTC sensor

Attention:

The Thermistor is placed beside of L1  
 The Thermistor is NTC  
 (Specification :T= 25℃ Resistance = 10±1% Kohm)  
 The resistance decreases with increasing temperature

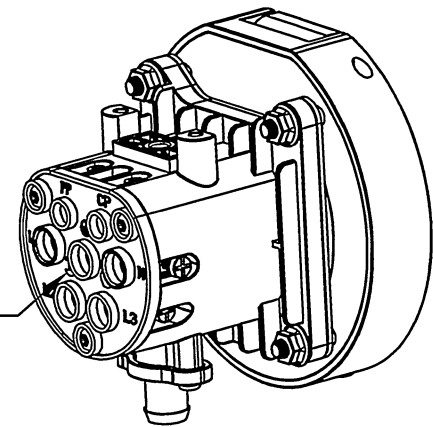

Size Measure Range	. XX	. X
≤6	±0.05	±0.10
6~30	±0.10	±0.20
30~120	±0.15	±0.30
120~400	±0.20	±0.50
400~1000	±0.30	±0.80
1000~2000	±0.50	±1.20
Angle Measure Range	. XX	. X
	±0.5°	±1.0°

PART NO.:	NINGBO DEGSON ELECTRICAL CO., LTD		
APPD: ZX 20191021	NAME: Socket-Outlet (16A AC three-phase )		
CHKD: DT 2019.10.21	FEAC-T-016A-P1-03-0.0M-25A(H)		
DRFT: LLL 2019-10-21	TITLE: Customer Drawing	REV	DO-1
THIRD ANGLE PROJECTION	DRAWING NO.:	SHEET	1/1
	MM (INCH)	DO NOT SCALE DRAWING	SCALE 2: 5