

100mW Transceiver Modules V1.0

1. General

HM-TRP series is a low cost, high performance transparent FSK transceiver with operating at 433/470/868/915 MHz. It features small size, high output power, high sensitivity, long transmission distance and high communication data rate with auto set up for communication change and data receiving and transmission control. There is UART interface, it is easy to realize the wireless data transmission with only providing the UART data. It is flexible for the users to set the UART baud rate, frequency, output power, data rate, frequency deviation, receiving bandwidth etc parameters. It is your ideal choice for designing wireless data transmission products which can be widely used on wireless data transmission field.

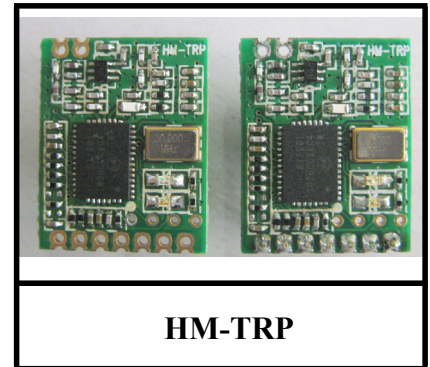

2. Features

- Low cost, high performance , high reliability
- FSK modulation, 2-way half –duplex communication, strong anti-interfere
- 433/470/868/915MHz ISM band, globally license free.
- Maximal output power100mW(20dBm), output power adjustable between 1-20dBm
- Sensitivity -117dBm
- Supply current for Tx 100mA@20dBm, 40mA@14dBm
- Supply current for Rx 25mA
- Low current sleep mode 1uA
- Standard TTL UART interface, extendable to RS232 or other interface
- Operation frequency can be configured, acceptable for several modules working in different frequency with no disturbance on each other.
- Optional for frequency deviation and receiving ISM bandwidth, users can be modulated by software.
- Easily use, auto exchange on communication & transceiver
- Communication speed 1.2kbps -115.2kbps, can be modulated through software
- Afford ENABLE control signal, user self control work duty cycle
- RSSI function
- With LED indication
- Longer transmission distance, over 1Km in open air
- Small size 16X20X2MM, 9 PIN DIP & 9 PIN SMD package, easy for assembly .
- Tuning free
- Accord FCC,ETSI standard

3. Application

- Remote control, remote measurement system;
- Wireless meter
- Access control
- Identification system

- Data collection
- Intelligence household appliance
- IT household appliance
- Baby monitoring system

4. Pin Description

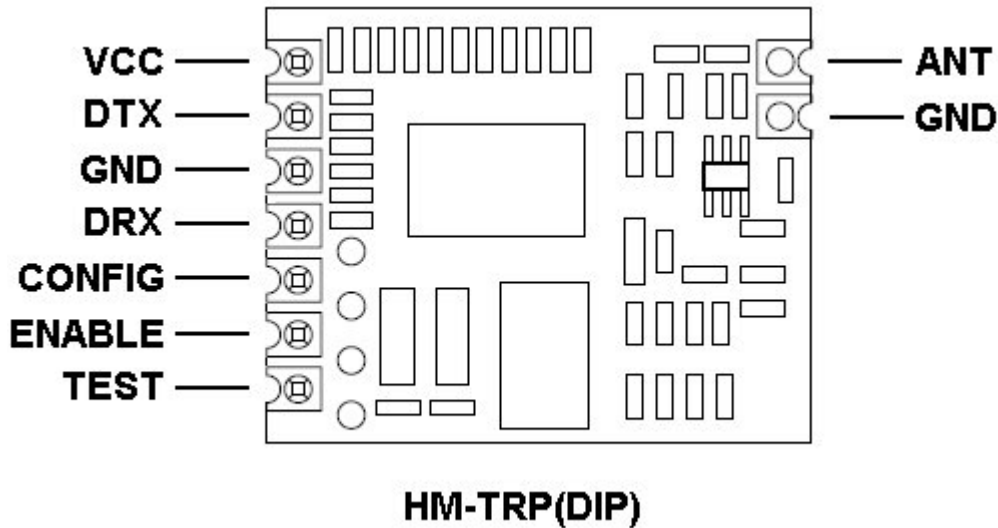

Figure 1. HM-TRP (DIP) Pin Description

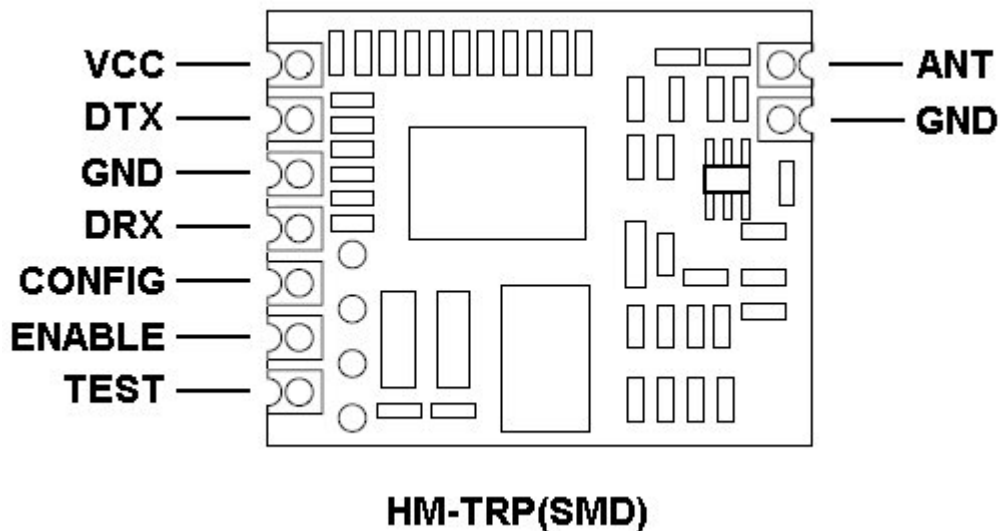

Figure 2. HM-TRP (SMD) Pin Description

Name	Note
VCC	Power supply,2.4-3.6V DC power, recommendation 3.3V DC power
DTX	Data transmission
GND	Ground
DRX	Data receiving
CONFIG	Set low for configuration mode, while set high for communication
ENABLE	Set low for normal mode for data transceiver , while back to sleep if set high
TEST	Dis-connected

ANT	Input/output interface with 50 ohm antenna
-----	--

5. Maximum specification

Parameter	Min	Max	Unit
Power supply(VCC)	-0.3	+3.6	V
Storage temperature	-40	+150	°C
Operate temperature	-40	+85	°C
Reflow temperature		+260	°C

6. Parameter

Parameter	Condition	Min	Typical	Max	Unit
Power supply (VCC)		2.4	3.3	3.6	V
Operate temperature		-40	25	85	°C
Operate frequency	HM-TRP-433	414	434	454	MHz
	HM-TRP-470	450	470	490	
	HM-TRP-868	849	869	889	
	HM-TRP-915	895	915	935	
Max output power		18	20		dBm
Output range		1		20	dBm
Receive Sensitivity	FSK,Fdev=35K, DR=1.2Kbps,		-117	-115	dBm
	FSK,Fdev=35K, DR=9.6Kbps,		-114	-112	
	FSK,Fdev=35K, DR=40Kbps		-111	-109	
	FSK,Fdev=35K, DR=100Kbps		-104	-102	
Tx Current	20dBm output power		100	120	mA
	14dBm output power		40	50	
Rx Current			25	30	mA
Sleep Current			1	2	uA
Modulate data rate		1.2		115.2	Kbps
Modulate deviation		10		160	KHz
Receive bandwidth		30		620	KHz
UART Data Rate		1.2		115.2	Kbps
UART data bit			8		bit
UART stop bit			1		bit

7. LED function

The HM-TRP add the LED function for easier debug & function demo, thus the users can easily understand whether the module is working or not or in any other status.

LED function:

1. The red and green LED will flash when there is power on if the module start working.
2. The module will be ready for Config status if ENABLE pin is low, CONFIG pin is low. It will be in Config if the red and green LED keep lighting. The green and red LED will not keep lighting if the module is not in Config mode.
3. The red LED flash when the module is in transmission , the red LED will be off if the transmission finished.
4. The green LED is off when the module is in receiving status, the green led will flash once if the module receive data.

8. Config Instruction

You need to Config the parameter and inquiry for different need to realize the function. The HM-TRP can Config and inquiry for working frequency, wireless data rate , receiving ISM bandwidth, frequency deviation, transmission power, UART transfer baud rate & RSSI signal reading etc.

Config and Inquiry methods:

The module will be ready for Config status if ENABLE pin is low, CONFIG pin is low. It will be in Config if the red and green LED keep lighting. Then you can Config & inquiry on the module.

The Config instruction format is as AA FA+[instruction]+[parameter].The instruction is 1 byte, the parameter is the HEX data of 0-4 byte which the high byte before the low byte.

The instruction's transfer speed should keeps the same as the transfer speed of UART. The instruction's transfer speed will change accordingly if changes the transfer speed of UART .The range of transfer speed of the instruction is from 1.2Kbps –115.2K bps.

Config& Inquiry instruction description:

1. Instruction[F0]:
Reset to default parameter, no parameter follows
Config instruction: AA FA F0
2. Instruction[E1]:
Reading the current Config parameter, no parameter follows
Config instruction: AA FA E1
3. Instruction [D2]:
Set up working frequency, [parameter]4 byte, [parameter] Unit :Hz
Set up range:
HM-TRP-433: 414000000-454000000Hz
HM-TRP-470: 450000000-490000000Hz
HM-TRP-868: 849000000-889000000Hz

HM-TRP-915: 895000000-935000000Hz

Example:

Config instruction: AA FA D2 36 89 CA C0, set up frequency as 915000000Hz

Config instruction: AA FA D2 19 DE 50 80, set up frequency as 434000000Hz

4. Instruction [C3]:

Set up wireless data rate, [parameter]4 byte, [parameter] unit :bps

Set up range:1200-115200 bps

Example:

Config instruction: AA FA C3 00 00 25 80, set up transfer speed as 9600bps

Config instruction: AA FA C3 00 00 96 00, set up transfer speed as 38400bps

5. Instruction[B4]:

Set up receiving bandwidth, [parameter]2 byte, [parameter]Unit :KHz

Set up range:30-620KHz

Example:

Config instruction: AA FA B4 00 69, set up receiving band as 105KHz

Config instruction: AA FA B4 01 2C, set up receiving band as 300KHz

6. Instruction[A5]:

Set up frequency deviation, [parameter]1 byte, [parameter]Unit :KHz

Set up range:10-160KHz

Example:

Config instruction: AA FA A5 23, set up modulation frequency as 35KHz

Config instruction: AA FA A5 32, set up modulation frequency as 50KHz

7. Instruction[96]:

Set up transmission power ,[parameter]1 byte, 0~7level

Set up range:0-7level(1-20 dBm)

Example:

Config instruction: AA FA 96 07, set up transmission power as level 7 (+20 dBm)

Config instruction:AA FA 96 03, set up transmission power as level 3 (+8 dBm)

Transmission power level	Transmission power
7	+20dBm
6	+17dBm
5	+14dBm
4	+11dBm
3	+8dBm
2	+5dBm
1	+2dBm
0	+1dBm

Table1: Transmission level

8. Instruction[1E]:
 Set up UART transfer speed, [parameter]4 byte, [parameter] unit: bps
 Set up range:1200-115200 bps

Example:

Config Instruction :AA FA 1E 00 00 25 80,set up speed as 9600bps

Config instruction :AA FA 1E 00 00 96 00, set up speed as 38400bps

9. Instruction [87]:
 Wireless signal strength when receiving useful data, follows no [parameter]
 Config Instruction: AA FA 87
 RSSI value is 8 bit, range: 0-255,
 Refer to Table 2 for wireless signal strength & RSSI

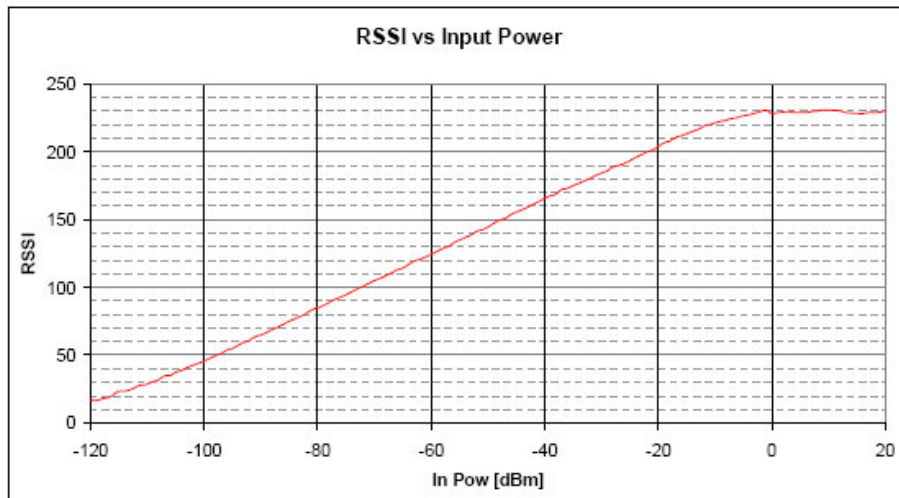

Table 2: wireless signal strength & RSSI

10. Instruction[78]:
 Disturb wireless signal strength, follows no [parameter]
 Config Instruction: AA FA 78
 RSSI value is 8 bit , range: 0-255
 Refer to Table 2 for wireless signal strength & RSSI

Note:

Modulation index : $h = Fd/Rb$, Range is 0.5 ~ 32.

If $h > 1$, $BW = Rb + 2Fd$; If $h < 1$, $BW = 2Rb + Fd$.

9. Original default parameter

module	Operate frequency (MHz)	Modulate data rate (Kbps)	Receive bandwidth (KHz)	Modulate deviation (KHz)	output power (dBm)	UART data rate (Kbps)
HM-TRP-433D(S)	434.000	9.600	105	35	+20	9.600
HM-TRP-470D(S)	470.000	9.600	105	35	+20	9.600
HM-TRP-868D(S)	869.000	9.600	105	35	+20	9.600
HM-TRP-915D(S)	915.000	9.600	105	35	+20	9.600

Table 3: Original default parameter

10. TTL & RS232 Typical Application

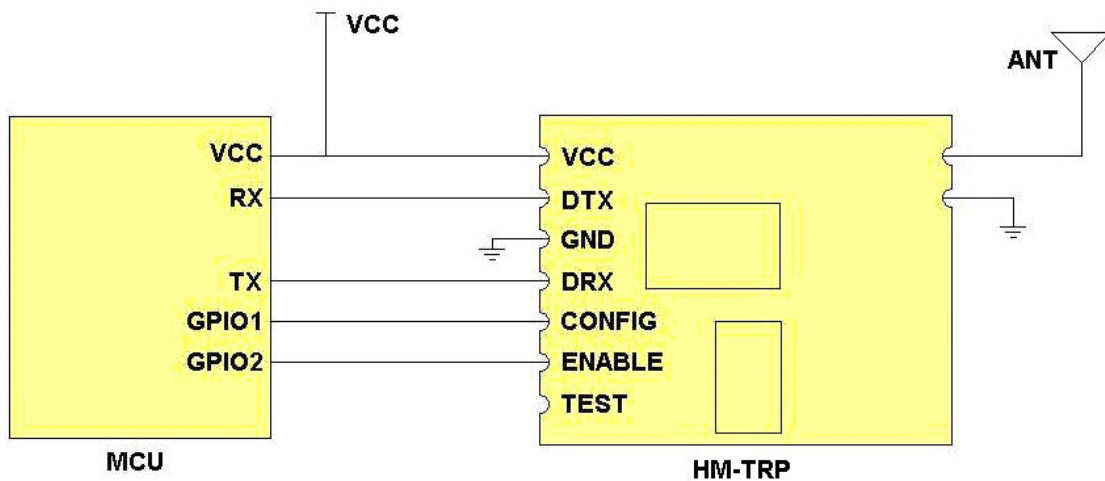

Figure 3.HM-TRP TTL UART Application

In Figure 3, connect the DTX pin of HM-TRP with UART RX Pin of MCU, connect the DRX pin of HM-TRP with the UART TX pin of MCU. Then the CONFIG & ENABLE of HM-TRP connects with the GPIO of MCU, thus the minimal application of TTL is set up.

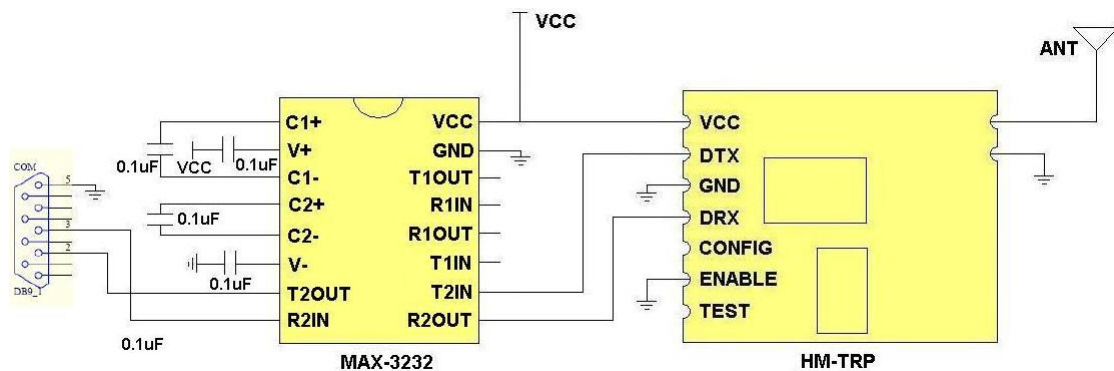

Figure 4. HM-TRP extends to RS232 application

In Figure 4, you can extend the HM-TRP to RS232 with adding the MAX3232, then you can directly connect the COM to the PC.

11. Mechanical Dimension (size unit: mm)

(DIP package)

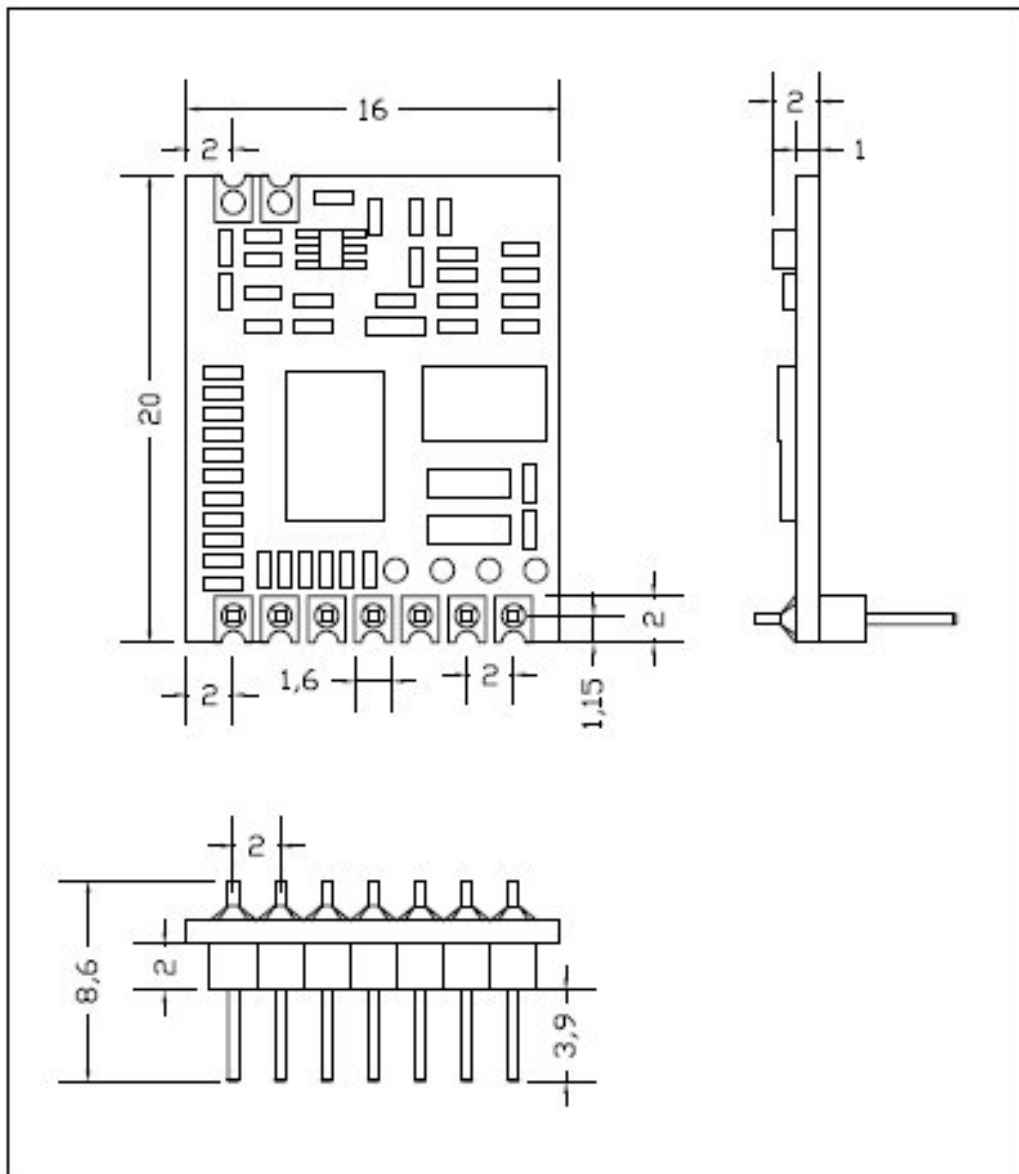

Figure 5.HM-TRP (DIP package) mechanical dimension

(SMD package)

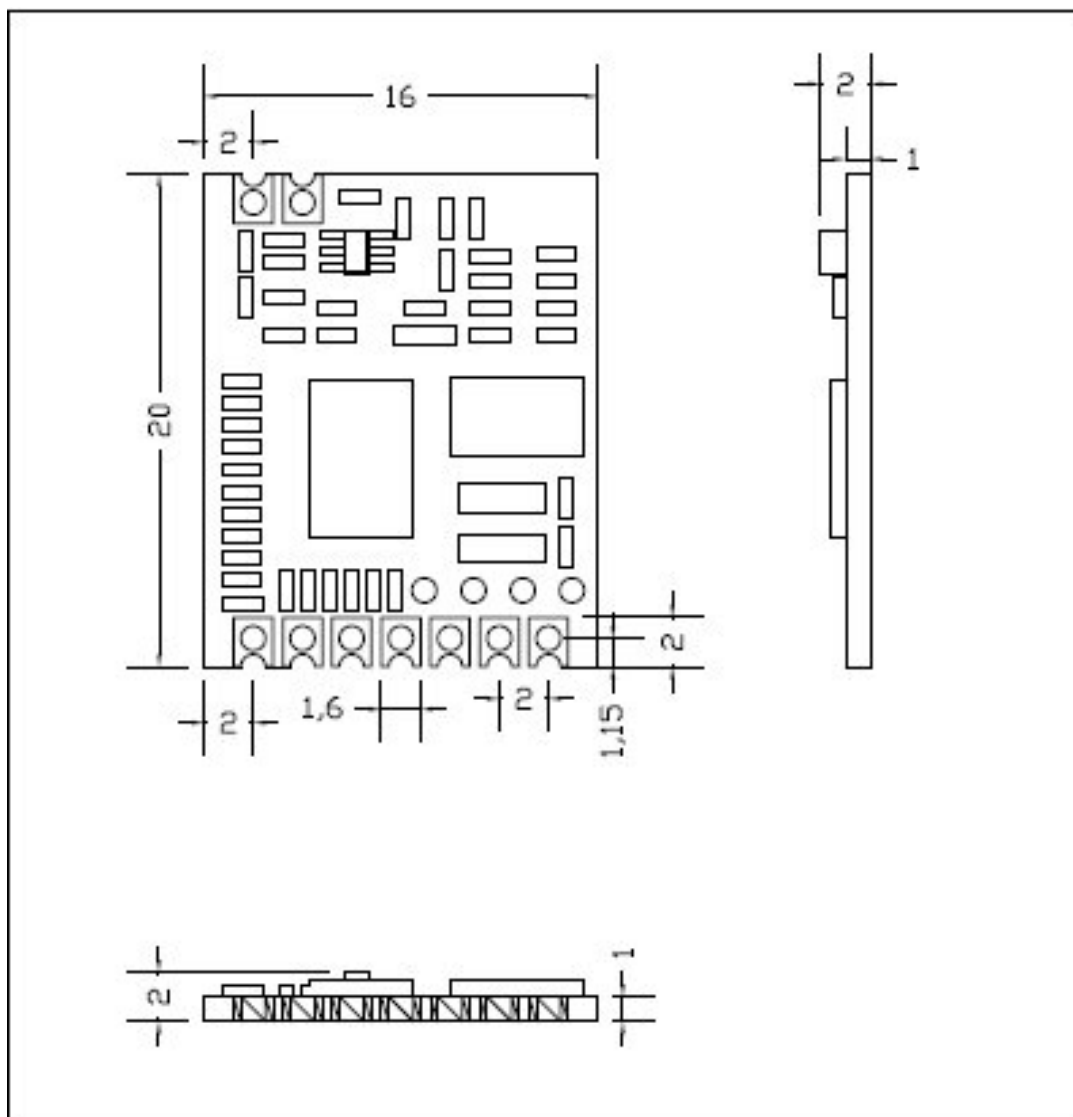
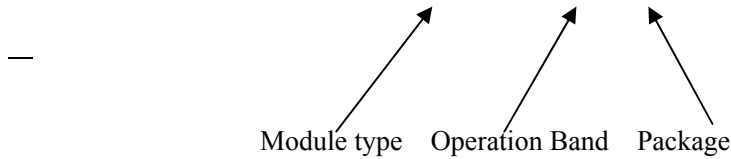

Figure 6.HM-TRP (SMD package) mechanical dimension

12. Ordering Information

Part Number=Module type – Operation Band – Package type

HM-TRP-433 D



Module type	Operation Band	Package
HM-TRP-433D	433MHZ	9 PIN DIP
HM -TRP-433S	433MHZ	9 PIN SMD
HM -TRP-470D	470 MHZ	9 PIN DIP
HM -TRP-470S	470 MHZ	9 PIN SMD
HM -TRP-868D	868 MHZ	9 PIN DIP
HM -TRP-868S	868 MHZ	9 PIN SMD
HM -TRP-915D	915 MHZ	9 PIN DIP
HM -TRP-915S	915MHZ	9 PIN SMD

Table 4: Module list

HOPE MICROELECTRONICS CO.,LTD

Add:4/F, Block B3, East Industrial Area, Huaqiaocheng,
Shenzhen, Guangdong, China

Tel: 86-755-82973805

Fax: 86-755-82973550

Email: sales@hoperf.com

trade@hoperf.com

Website: <http://www.hoperf.com>

<http://hoperf.en.alibaba.com>

This document may contain preliminary information and is subject to change by Hope Microelectronics without notice. Hope Microelectronics assumes no responsibility or liability for any use of the information contained herein. Nothing in this document shall operate as an express or implied license or indemnity under the intellectual property rights of Hope Microelectronics or third parties. The products described in this document are not intended for use in implantation or other direct life support applications where malfunction may result in the direct physical harm or injury to persons. NO WARRANTIES OF ANY KIND, INCLUDING, BUT NOT LIMITED TO, THE IMPLIED WARRANTIES OF MERCHANTABILITY OR FITNESS FOR A PARTICULAR PURPOSE, ARE OFFERED IN THIS DOCUMENT.

©2006, HOPE MICROELECTRONICS CO.,LTD. All rights reserved.