

TCA9539-Q1 Low Voltage 16-Bit I²C and SMBus Low-Power I/O Expander with Interrupt Output, Reset Pin, and Configuration Registers

1 Features

- Qualified for Automotive Applications
- I²C to Parallel Port Expander
- Open-Drain Active-Low Interrupt Output
- Active-Low Reset Input
- 5-V Tolerant Input and Output Ports
- Compatible With Most Microcontrollers
- 400-kHz Fast I²C Bus
- Polarity Inversion Register
- Internal Power-on-Reset
- No Glitch on Power Up
- Address by Two Hardware Address Pins for Use of up to Four Devices
- Latched Outputs for Directly Driving LEDs
- Latch-Up Performance Exceeds 100-mA Per JESD 78, Class II
- ESD Protection Exceeds JESD 22
 - 2000-V Human-Body Model (A114-A)
 - 1000-V Charged-Device Model (C101)

2 Applications

- Automotive infotainment, Advanced Driver Assistance Systems (ADAS), Automotive body electronics, HEV, EV and Powertrain
- Industrial automation, Factory automation, Building automation, Test & measurement, EPOS
- I²C GPIO expansion

3 Description

The TCA9539-Q1 is a 24-pin device that provides 16 bits of general purpose parallel input and output (I/O) expansion for the two-line bidirectional I²C bus (or SMBus protocol). The device can operate with a power supply voltage (V_{CC}) range from 1.65 V to 3.6 V. The device supports 100-kHz (I²C Standard mode) and 400-kHz (I²C Fast mode) clock frequencies. I/O expanders such as the TCA9539-Q1 provide a simple solution when additional I/Os are needed for switches, sensors, push-buttons, LEDs, fans, and other similar devices.

The features of the TCA9539-Q1 include an interrupt that is generated on the \overline{INT} pin whenever an input port changes state. The A0 and A1 hardware selectable address pins allow up to four TCA9539-Q1 devices on the same I²C bus. The device can be reset to its default state by cycling the power supply and causing a power-on-reset. Also, the TCA9539-Q1 has a hardware \overline{RESET} pin that can be used to reset the device to its default state.

The TCA9539-Q1 I²C I/O expander is qualified for automotive applications.

Device Information⁽¹⁾

PART NUMBER	PACKAGE TYPE	BODY SIZE (NOM)
TCA9539-Q1	TSSOP (24)	7.80 mm x 4.40 mm

(1) For all available packages, see the orderable addendum at the end of the data sheet.

Simplified Block Diagram

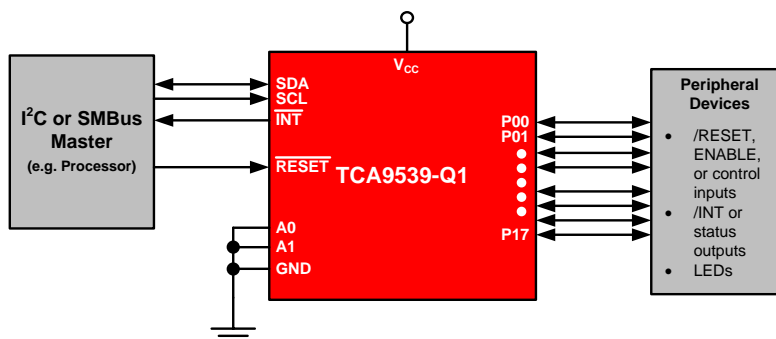

Copyright © 2016, Texas Instruments Incorporated



Table of Contents

1 Features	1	8.4 Device Functional Modes	18
2 Applications	1	8.5 Programming	18
3 Description	1	8.6 Register Maps	20
4 Revision History	2	9 Application and Implementation	26
5 Pin Configuration and Functions	3	9.1 Application Information	26
6 Specifications	4	9.2 Typical Application	26
6.1 Absolute Maximum Ratings	4	10 Power Supply Recommendations	29
6.2 ESD Ratings	4	10.1 Power-On Reset Requirements	29
6.3 Recommended Operating Conditions	4	11 Layout	30
6.4 Thermal Information	5	11.1 Layout Guidelines	30
6.5 Electrical Characteristics	5	11.2 Layout Example	31
6.6 I ² C Interface Timing Requirements	6	12 Device and Documentation Support	32
6.7 $\overline{\text{RESET}}$ Timing Requirements	7	12.1 Documentation Support	32
6.8 Switching Characteristics	7	12.2 Receiving Notification of Documentation Updates	32
6.9 Typical Characteristics	8	12.3 Community Resources	32
7 Parameter Measurement Information	11	12.4 Trademarks	32
8 Detailed Description	15	12.5 Electrostatic Discharge Caution	32
8.1 Overview	15	12.6 Glossary	32
8.2 Functional Block Diagram	16	13 Mechanical, Packaging, and Orderable Information	32
8.3 Feature Description	17		

4 Revision History

Changes from Revision B (April 2016) to Revision C	Page
• Changed the appearance of the PW pinout image	3
• Removed (5 V) from the V _{CC} label in Figure 31	26

Changes from Revision A (September 2015) to Revision B	Page
• Changed device status from <i>Product Preview</i> to <i>Production Data</i>	1

Changes from Original (January 2014) to Revision A	Page
• Added ESD Ratings table, Feature Description section, Device Functional Modes, Application and Implementation section, Power Supply Recommendations section, Layout section, Device and Documentation Support section, and Mechanical, Packaging, and Orderable Information section.	1

5 Pin Configuration and Functions

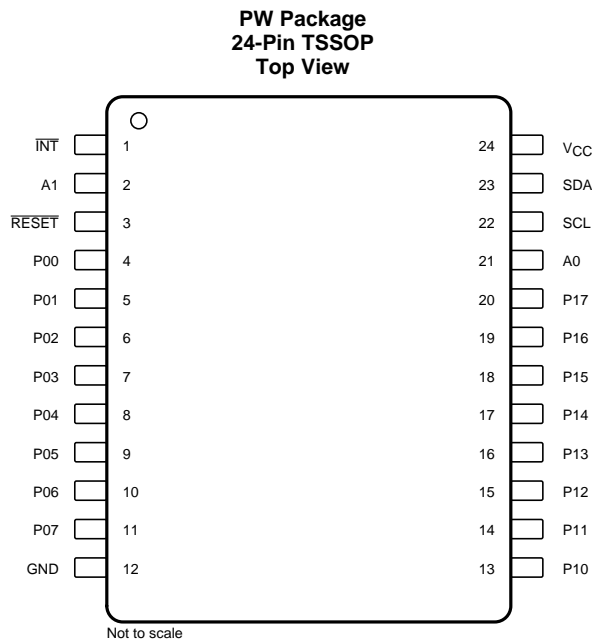

Pin Functions

PIN		I/O	DESCRIPTION
NO.	NAME		
1	INT	O	Interrupt open-drain output. Connect to V_{CC} through a pull-up resistor
2	A1	I	Address input. Connect directly to V_{CC} or ground
3	RESET	I	Active-low reset input. Connect to V_{CC} through a pull-up resistor if no active connection is used
4	P00	I/O	P-port input-output. Push-pull design structure. At power-on, P00 is configured as an input
5	P01	I/O	P-port input-output. Push-pull design structure. At power-on, P01 is configured as an input
6	P02	I/O	P-port input-output. Push-pull design structure. At power-on, P02 is configured as an input
7	P03	I/O	P-port input-output. Push-pull design structure. At power-on, P03 is configured as an input
8	P04	I/O	P-port input-output. Push-pull design structure. At power-on, P04 is configured as an input
9	P05	I/O	P-port input-output. Push-pull design structure. At power-on, P05 is configured as an input
10	P06	I/O	P-port input-output. Push-pull design structure. At power-on, P06 is configured as an input
11	P07	I/O	P-port input-output. Push-pull design structure. At power-on, P07 is configured as an input
12	GND	—	Ground
13	P10	I/O	P-port input-output. Push-pull design structure. At power-on, P10 is configured as an input
14	P11	I/O	P-port input-output. Push-pull design structure. At power-on, P11 is configured as an input
15	P12	I/O	P-port input-output. Push-pull design structure. At power-on, P12 is configured as an input
16	P13	I/O	P-port input-output. Push-pull design structure. At power-on, P13 is configured as an input
17	P14	I/O	P-port input-output. Push-pull design structure. At power-on, P14 is configured as an input
18	P15	I/O	P-port input-output. Push-pull design structure. At power-on, P15 is configured as an input
19	P16	I/O	P-port input-output. Push-pull design structure. At power-on, P16 is configured as an input
20	P17	I/O	P-port input-output. Push-pull design structure. At power-on, P17 is configured as an input
21	A0	I	Address input. Connect directly to V_{CC} or ground
22	SCL	I	Serial clock bus. Connect to V_{CC} through a pull-up resistor
23	SDA	I/O	Serial data bus. Connect to V_{CC} through a pull-up resistor
24	V_{CC}	—	Supply voltage

6 Specifications

6.1 Absolute Maximum Ratings

 over operating free-air temperature range (unless otherwise noted) ⁽¹⁾

		MIN	MAX	UNIT	
V _{CC}	Supply voltage	-0.5	3.6	V	
V _I	Input voltage ⁽²⁾	-0.5	6	V	
V _O	Output voltage ⁽²⁾	-0.5	6	V	
I _{IK}	Input clamp current		V _I < 0	-20	mA
I _{OK}	Output clamp current		V _O < 0	-20	mA
I _{I_{OK}}	Input-output clamp current		V _O < 0 or V _O > V _{CC}	±20	mA
I _{OL}	Continuous output low current		V _O = 0 to V _{CC}	50	mA
I _{OH}	Continuous output high current		V _O = 0 to V _{CC}	-50	mA
I _{CC}	Continuous current through GND			-250	mA
	Continuous current through V _{CC}			160	
T _{j(MAX)}	Maximum junction temperature			135	°C
T _{stg}	Storage temperature	-65	150		°C

- (1) Stresses beyond those listed under *Absolute Maximum Ratings* may cause permanent damage to the device. These are stress ratings only, which do not imply functional operation of the device at these or any other conditions beyond those indicated under *Recommended Operating Conditions*. Exposure to absolute-maximum-rated conditions for extended periods may affect device reliability.
- (2) The input negative voltage and output voltage ratings may be exceeded if the input and output current ratings are observed.

6.2 ESD Ratings

		VALUE	UNIT
V _(ESD)	Electrostatic discharge	Human-body model (HBM), per AEC Q100-002 ⁽¹⁾	±2000
		Charged-device model (CDM), per AEC Q100-011	±1000

- (1) AEC Q100-002 indicates that HBM stressing shall be in accordance with the ANSI/ESDA/JEDEC JS-001 specification.

6.3 Recommended Operating Conditions

over operating free-air temperature range (unless otherwise noted)

		MIN	MAX	UNIT	
V _{CC}	Supply voltage	1.65	3.6	V	
V _{I/O}	I/O ports voltage	SCL, SDA, A0, A1, $\overline{\text{RESET}}$, $\overline{\text{INT}}$ ⁽¹⁾	-0.5	5.5	V
		For P00–P07, P10–P17 configured as outputs	-0.5	3.6	V
		For P00–P07, P10–P17 configured as inputs ⁽¹⁾	-0.5	5.5	V
V _{IH}	High-level input voltage	SCL, SDA, A0, A1, $\overline{\text{RESET}}$, P07–P00, P10–P17	0.7 × V _{CC}	V	
V _{IL}	Low-level input voltage	SCL, SDA, A0, A1, $\overline{\text{RESET}}$, P07–P00, P10–P17	0.3 × V _{CC}	V	
I _{OH}	High-level output current	P00–P07, P10–P17	-10	mA	
I _{OL} ⁽²⁾	Low-level output current	P00–P07, P10–P17	T _j ≤ 65°C	25	mA
			T _j = 85°C	18	
			T _j = 105°C	9	
			T _j = 125°C	4.5	
			T _j = 135°C	3.5	
I _{OL} ⁽²⁾	Low-level output current	$\overline{\text{INT}}$, SDA	T _j ≤ 85°C	6	mA
			T _j = 105°C	3	
			T _j = 125°C	1.8	
			T _j = 135°C	1.5	
T _A	Operating free-air temperature	-40	125	°C	

- (1) For voltages applied above V_{CC}, an increase in I_{CC} results.
- (2) The values shown apply to specific junction temperatures. See the [Calculating Junction Temperature and Power Dissipation](#) section on how to calculate the junction temperature.

6.4 Thermal Information

THERMAL METRIC ⁽¹⁾		TCA9539-Q1	
		PW (TSSOP)	
		24 PINS	
Symbol	Description	Value	UNIT
R _{θJA}	Junction-to-ambient thermal resistance	108.8	°C/W
R _{θJC(top)}	Junction-to-case (top) thermal resistance	54	°C/W
R _{θJB}	Junction-to-board thermal resistance	62.8	°C/W
ψ _{JT}	Junction-to-top characterization parameter	11.1	°C/W
ψ _{JB}	Junction-to-board characterization parameter	62.3	°C/W

(1) For more information about traditional and new thermal metrics, see the *Semiconductor and IC Package Thermal Metrics* application report, [SPRA953](#).

6.5 Electrical Characteristics

over recommended operating free-air temperature range (unless otherwise noted)

PARAMETER		TEST CONDITIONS	V _{CC}	MIN	TYP ⁽¹⁾	MAX	UNIT	
V _{IK}	Input diode clamp voltage	I _I = -18 mA	1.65 V to 3.6 V	-1.2			V	
V _{PORR}	Power-on reset voltage, V _{CC} rising	V _I = V _{CC} or GND	1.65 V to 3.6 V		1.2	1.5	V	
V _{PORF}	Power-on reset voltage, V _{CC} falling	V _I = V _{CC} or GND	1.65 V to 3.6 V	0.75	1		V	
V _{OH}	P-port high-level output voltage ⁽²⁾	I _{OH} = -8 mA	1.65 V	1.2			V	
			2.3 V	1.8				
			3 V	2.6				
			3.6 V	3.3				
		I _{OH} = -10 mA	1.65 V	1				
			2.3 V	1.7				
			3 V	2.5				
			3.6 V	3.2				
I _{OL}	SDA	V _{OL} = 0.4 V	1.65 V to 3.6 V	3			mA	
	P port ⁽³⁾	V _{OL} = 0.5 V		8				
		V _{OL} = 0.7 V		10				
	$\overline{\text{INT}}$	V _{OL} = 0.4 V		3				
I _I	SCL, SDA	V _I = V _{CC} or GND	1.65 V to 3.6 V			±1	µA	
	A0, A1, $\overline{\text{RESET}}$					±1		
I _{IH}	P port	V _I = V _{CC}	1.65 V to 3.6 V			1	µA	
I _{IL}	P port	V _I = GND	1.65 V to 3.6 V			-1	µA	
I _{CC}	Operating mode	V _I = V _{CC} or GND, I _O = 0, I/O = inputs, f _{SCL} = 400-kHz, no load	3.6 V		10	30	µA	
			2.7 V		5	19		
			1.95 V		4	11		
	Standby mode	I _O = 0, I/O = inputs, f _{SCL} = 0-kHz, no load	V _I = V _{CC}	3.6 V		1.1		5
				2.7 V		1		4.5
				1.95 V		0.4		3.5
			V _I = GND	3.6 V		1.1		13
				2.7 V		1		9.5
				1.95 V		0.4		6.5
C _i	SCL	V _I = V _{CC} or GND	1.65 V to 3.6 V		3	8	pF	

(1) All typical values are at nominal supply voltage (1.8 V, 2.5 V, or 3.3 V, V_{CC}) and T_A = 25°C.

(2) Each I/O must be externally limited to the maximum allowed I_{OL}, and each octal (P07–P00 and P17–P10) must be limited to a maximum current of 100 mA, for a device total of 200 mA at T_j ≤ 85°C. See the [Recommended Operating Conditions](#) table for more information.

(3) The total current sourced by all I/Os must be limited to 160 mA (80 mA for P07–P00 and 80 mA for P17–P10) for T_j ≤ 85°C. See the [Recommended Operating Conditions](#) table for more information.

Electrical Characteristics (continued)

over recommended operating free-air temperature range (unless otherwise noted)

PARAMETER		TEST CONDITIONS	V _{CC}	MIN	TYP ⁽¹⁾	MAX	UNIT
C _{IO}	SDA	V _{IO} = V _{CC} or GND	1.65 V to 3.6 V		3	9.5	pF
	P port				3.7	9.5	

6.6 I²C Interface Timing Requirements

 over recommended operating free-air temperature range (unless otherwise noted) (see [Figure 15](#))

			MIN	MAX	UNIT
I²C BUS—STANDARD MODE					
f _{scl}	I ² C clock frequency		0	100	kHz
t _{sch}	I ² C clock high time		4		μs
t _{scl}	I ² C clock low time		4.7		μs
t _{sp}	I ² C spike time			50	ns
t _{sds}	I ² C serial-data setup time		250		ns
t _{sdh}	I ² C serial-data hold time		0		ns
t _{icr}	I ² C input rise time			1000	ns
t _{icf}	I ² C input fall time			300	ns
t _{ocf}	I ² C output fall time	10-pF to 400-pF bus		300	ns
t _{buf}	I ² C bus free time between stop and start		4.7		μs
t _{sts}	I ² C start or repeated start condition setup		4.7		μs
t _{sth}	I ² C start or repeated start condition hold		4		μs
t _{sps}	I ² C stop condition setup		4		μs
t _{vd(data)}	Valid data time	SCL low to SDA output valid		3.45	μs
t _{vd(ack)}	Valid data time of ACK condition	ACK signal from SCL low to SDA (out) low		3.45	μs
C _b	I ² C bus capacitive load			400	pF

			MIN	MAX	UNIT
I²C BUS—FAST MODE					
f _{scl}	I ² C clock frequency		0	400	kHz
t _{sch}	I ² C clock high time		0.6		μs
t _{scl}	I ² C clock low time		1.3		μs
t _{sp}	I ² C spike time			50	ns
t _{sds}	I ² C serial-data setup time		100		ns
t _{sdh}	I ² C serial-data hold time		0		ns
t _{icr}	I ² C input rise time		20	300	ns
t _{icf}	I ² C input fall time		20 × (V _{CC} / 5.5 V)	300	ns
t _{ocf}	I ² C output fall time	10-pF to 400-pF bus	20 × (V _{CC} / 5.5 V)	300	ns
t _{buf}	I ² C bus free time between stop and start		1.3		μs
t _{sts}	I ² C start or repeated start condition setup		0.6		μs
t _{sth}	I ² C start or repeated start condition hold		0.6		μs
t _{sps}	I ² C stop condition setup		0.6		μs
t _{vd(data)}	Valid data time	SCL low to SDA output valid		0.9	μs
t _{vd(ack)}	Valid data time of ACK condition	ACK signal from SCL low to SDA (out) low		0.9	μs
C _b	I ² C bus capacitive load			400	pF

6.7 $\overline{\text{RESET}}$ Timing Requirements

over recommended operating free-air temperature range (unless otherwise noted) (see [Figure 18](#))

		MIN	MAX	UNIT
t_W	Reset pulse duration	6		ns
t_{REC}	Reset recovery time	0		ns
t_{RESET}	Time to reset; For $V_{\text{CC}} = 2.3 \text{ V} - 3.6 \text{ V}$	400		ns
	Time to reset; For $V_{\text{CC}} = 1.65 \text{ V} - 2.3 \text{ V}$	550		ns

6.8 Switching Characteristics

over recommended operating free-air temperature range, $C_L \leq 100 \text{ pF}$ (unless otherwise noted) (see [Figure 16](#) and [Figure 17](#))

PARAMETER		FROM (INPUT)	TO (OUTPUT)	MIN	MAX	UNIT
t_{IV}	Interrupt valid time	P port	$\overline{\text{INT}}$		4	μs
t_{IR}	Interrupt reset delay time	SCL	$\overline{\text{INT}}$		4	μs
t_{pv}	Output data valid; For $V_{\text{CC}} = 2.3 \text{ V} - 3.6 \text{ V}$	SCL	P port		200	ns
	Output data valid; For $V_{\text{CC}} = 1.65 \text{ V} - 2.3 \text{ V}$				300	ns
t_{ps}	Input data setup time	P port	SCL	150		ns
t_{ph}	Input data hold time	P port	SCL	1		μs

6.9 Typical Characteristics

T_A = 25°C (unless otherwise noted)

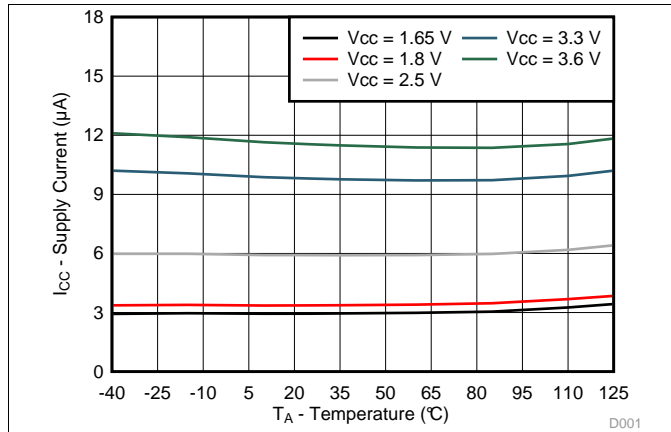

Figure 1. Supply Current vs Temperature for Different Supply Voltage (V_{CC})

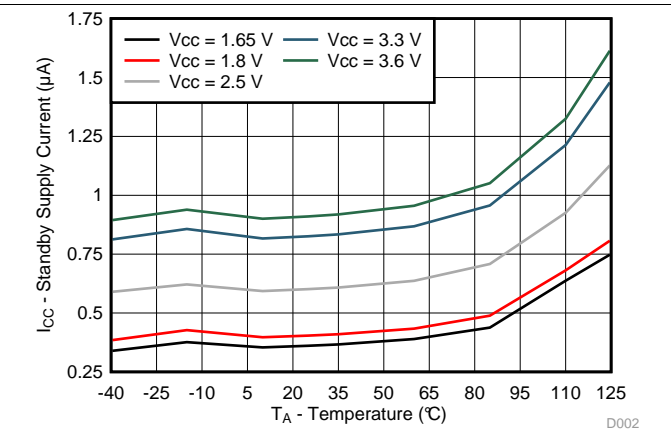

Figure 2. Standby Supply Current vs Temperature for Different Supply Voltage (V_{CC})

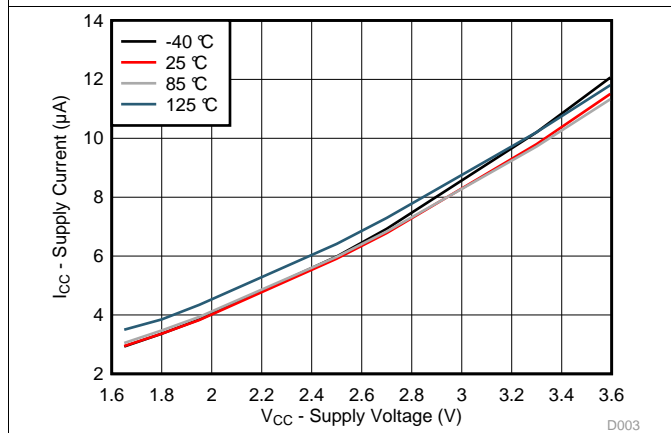

Figure 3. Supply Current vs Supply Voltage for Different Temperature (T_A)

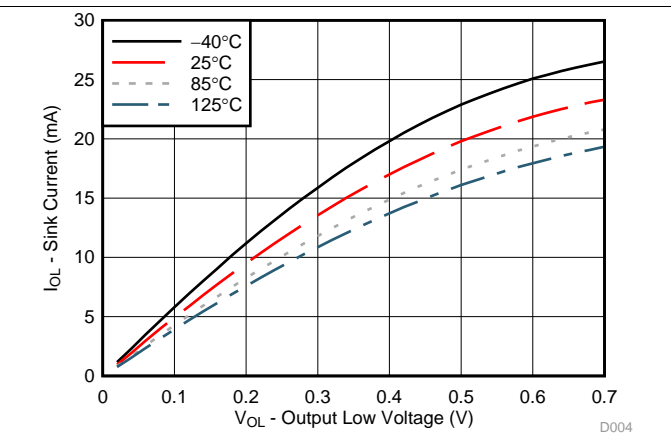

Figure 4. I/O Sink Current vs Output Low Voltage for Different Temperature (T_A) for V_{CC} = 1.65 V

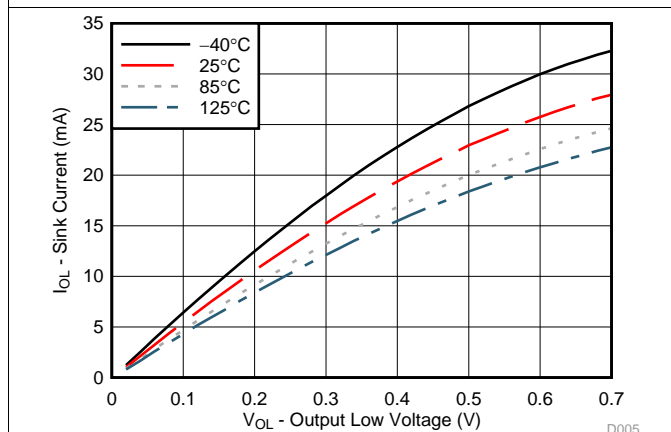

Figure 5. I/O Sink Current vs Output Low Voltage for Different Temperature (T_A) for V_{CC} = 1.8 V

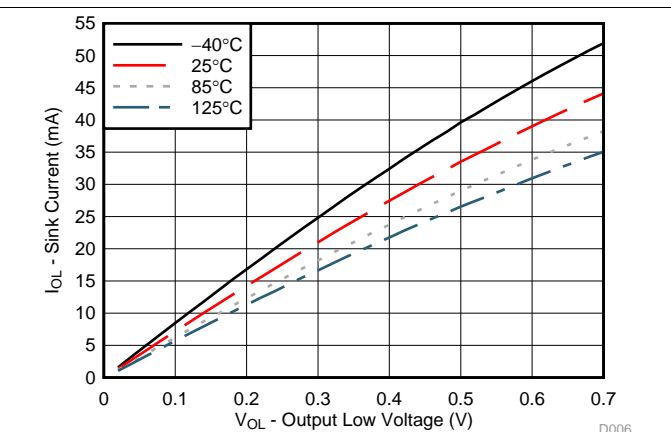
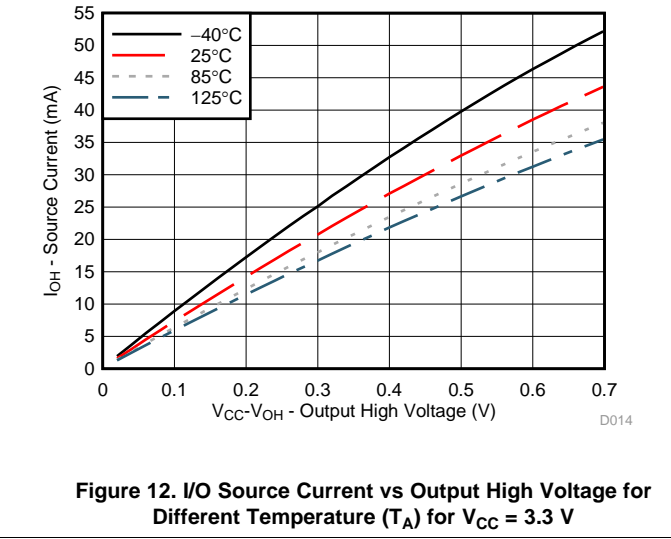
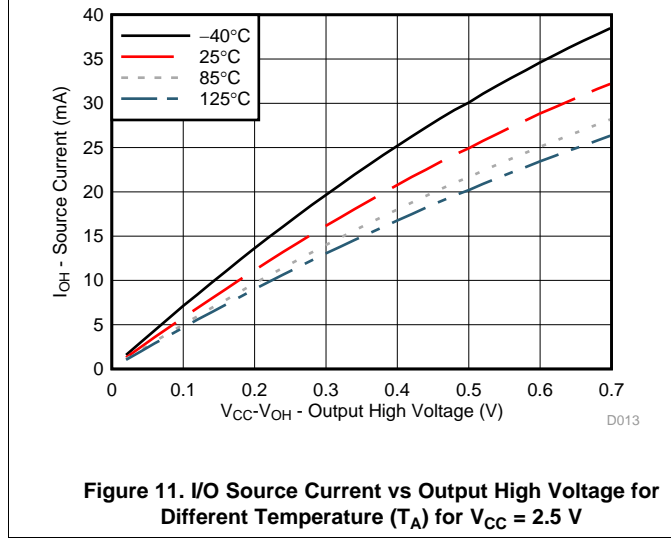
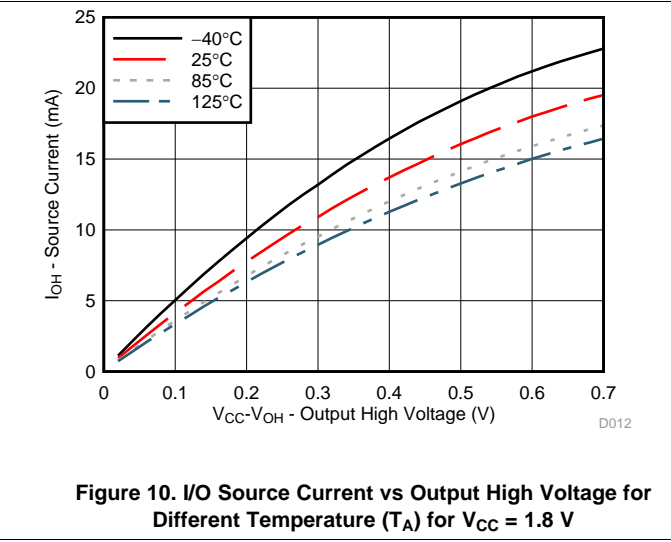
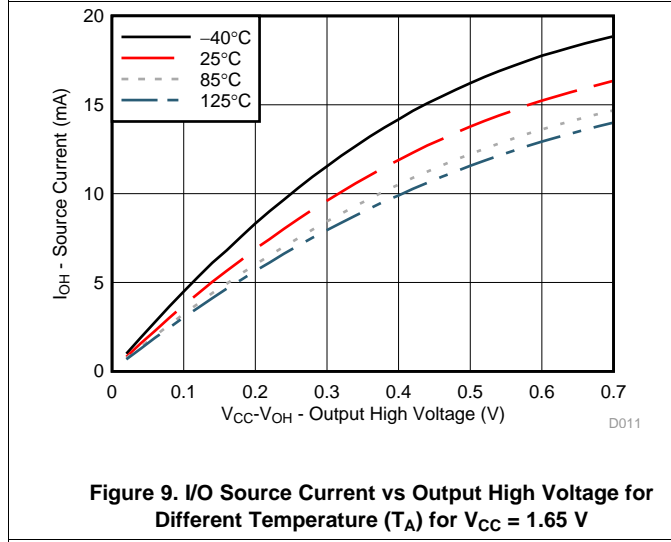
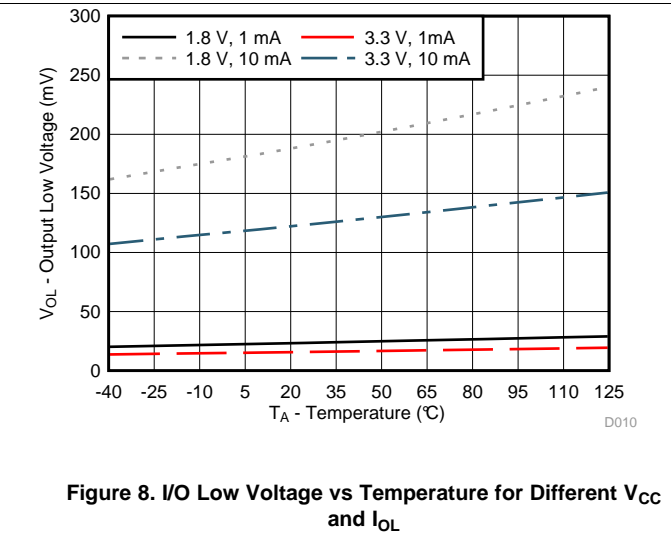
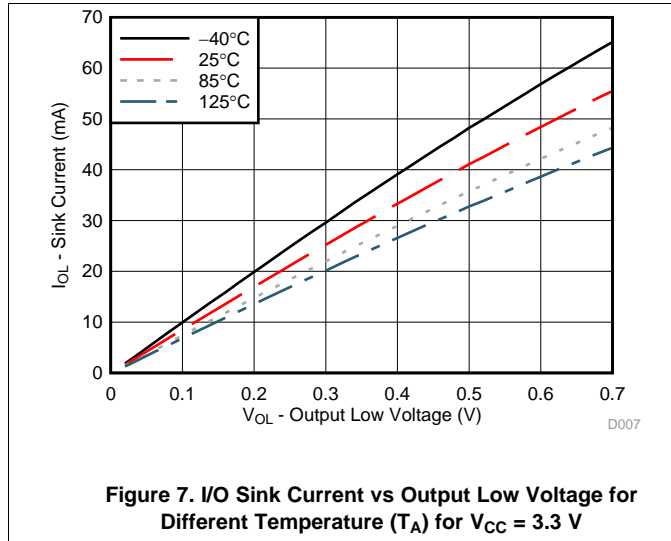

Figure 6. I/O Sink Current vs Output Low Voltage for Different Temperature (T_A) for V_{CC} = 2.5 V

Typical Characteristics (continued)

T_A = 25°C (unless otherwise noted)



Typical Characteristics (continued)

$T_A = 25^\circ\text{C}$ (unless otherwise noted)

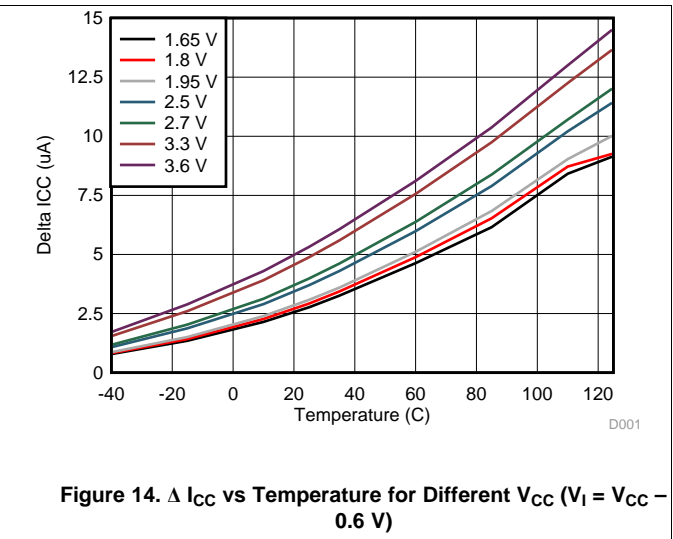
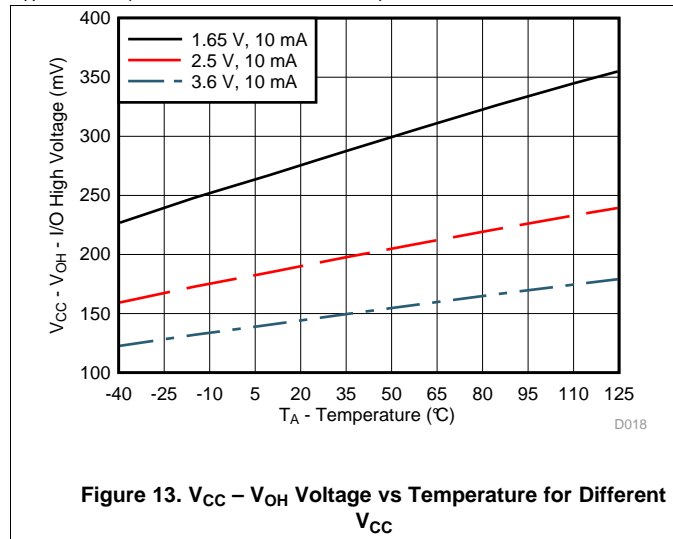

7 Parameter Measurement Information

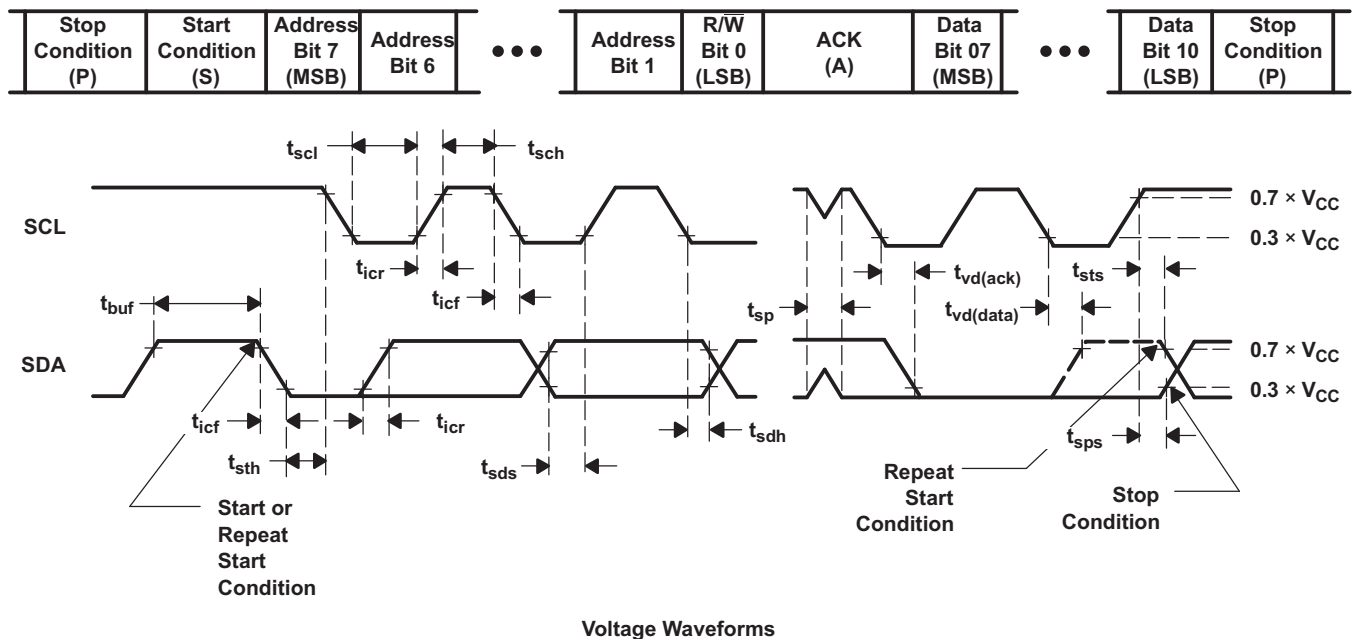
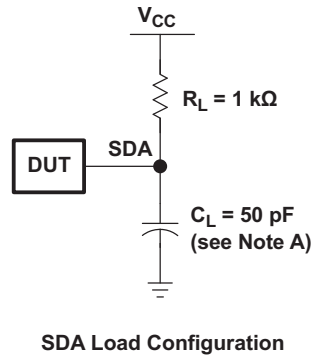

BYTE	DESCRIPTION
1	I ² C address
2, 3	P-port data

- A. C_L includes probe and jig capacitance.
- B. All inputs are supplied by generators having the following characteristics: $PRR \leq 10$ MHz, $Z_O = 50 \Omega$, $t_r/t_f \leq 30$ ns.
- C. All parameters and waveforms are not applicable to all devices.

Figure 15. I²C Interface Load Circuit and Voltage Waveforms

Parameter Measurement Information (continued)

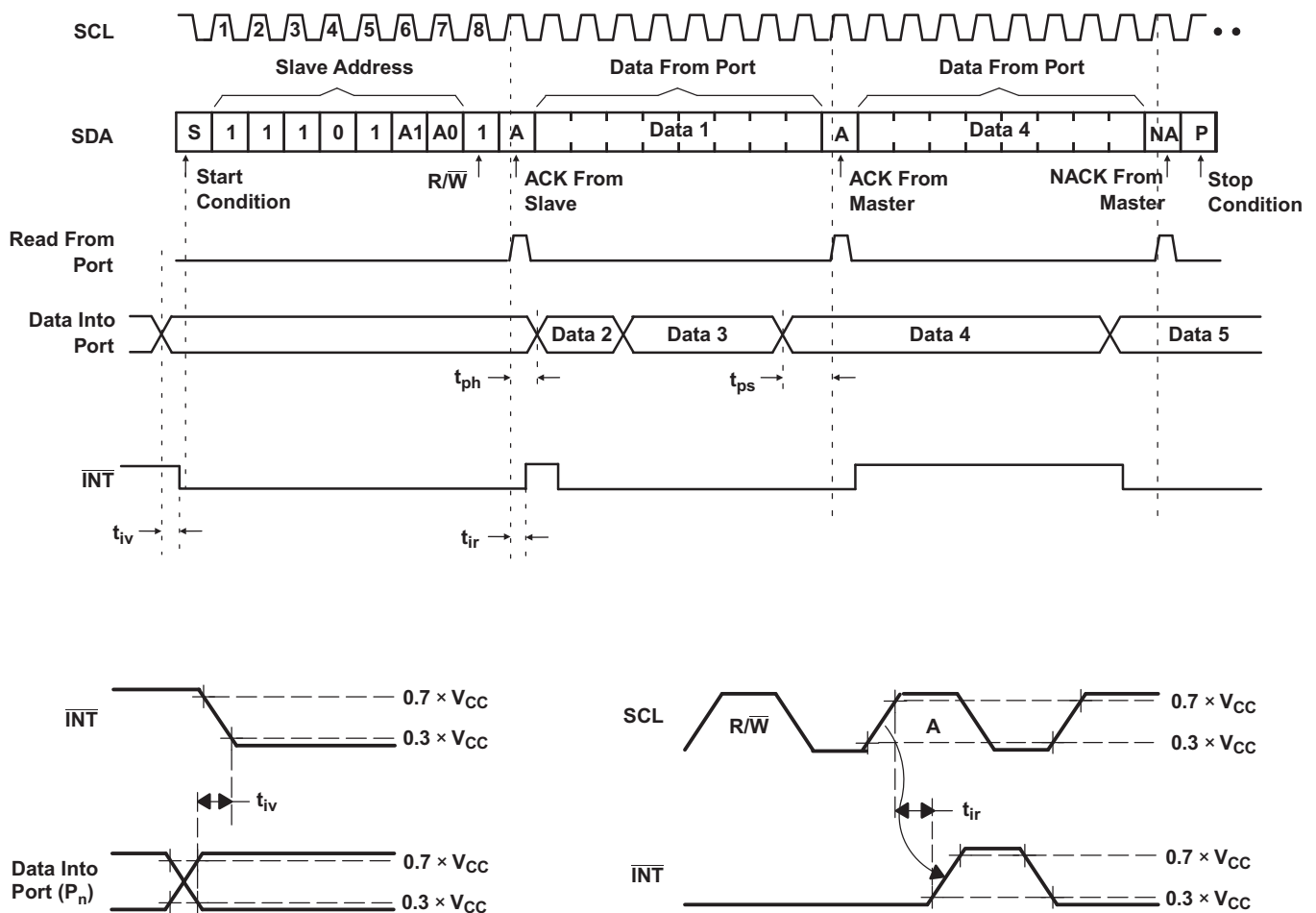
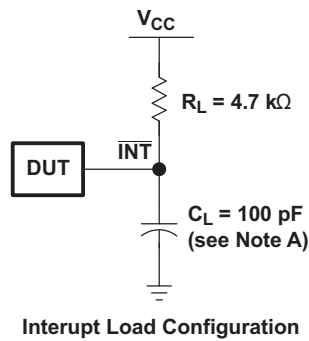

- A. C_L includes probe and jig capacitance.
- B. All inputs are supplied by generators having the following characteristics: PRR \leq 10 Hz, $Z_O = 50 \Omega$, $t_r/t_f \leq 30$ ns.
- C. All parameters and waveforms are not applicable to all devices.

Figure 16. Interrupt Load Circuit and Voltage Waveforms

Parameter Measurement Information (continued)

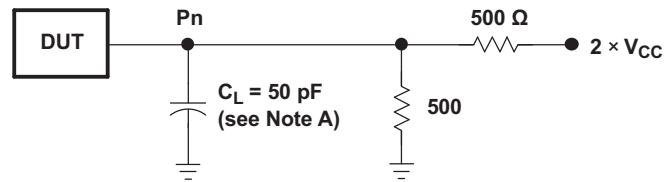

P-Port Load Configuration

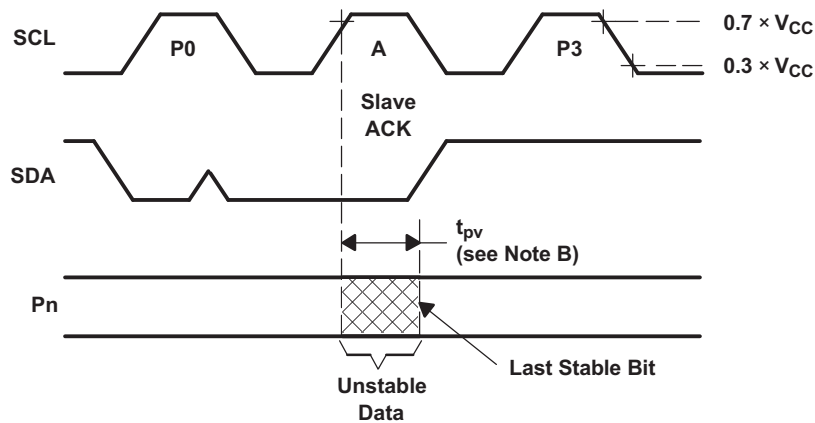

Write Mode ($R/\bar{W} = 0$)

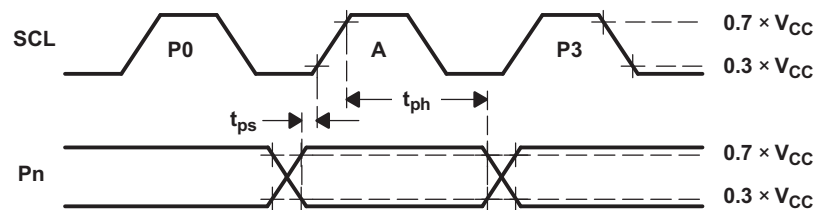

Read Mode ($R/\bar{W} = 1$)

- A. C_L includes probe and jig capacitance.
- B. t_{pv} is measured from $0.7 \times V_{CC}$ on SCL to 50% I/O (P_n) output.
- C. All inputs are supplied by generators having the following characteristics: $PRR \leq 10$ MHz, $Z_O = 50 \Omega$, $t_r/t_f \leq 30$ ns.
- D. The outputs are measured one at a time, with one transition per measurement.
- E. All parameters and waveforms are not applicable to all devices.

Figure 17. P-Port Load Circuit and Voltage Waveforms

Parameter Measurement Information (continued)

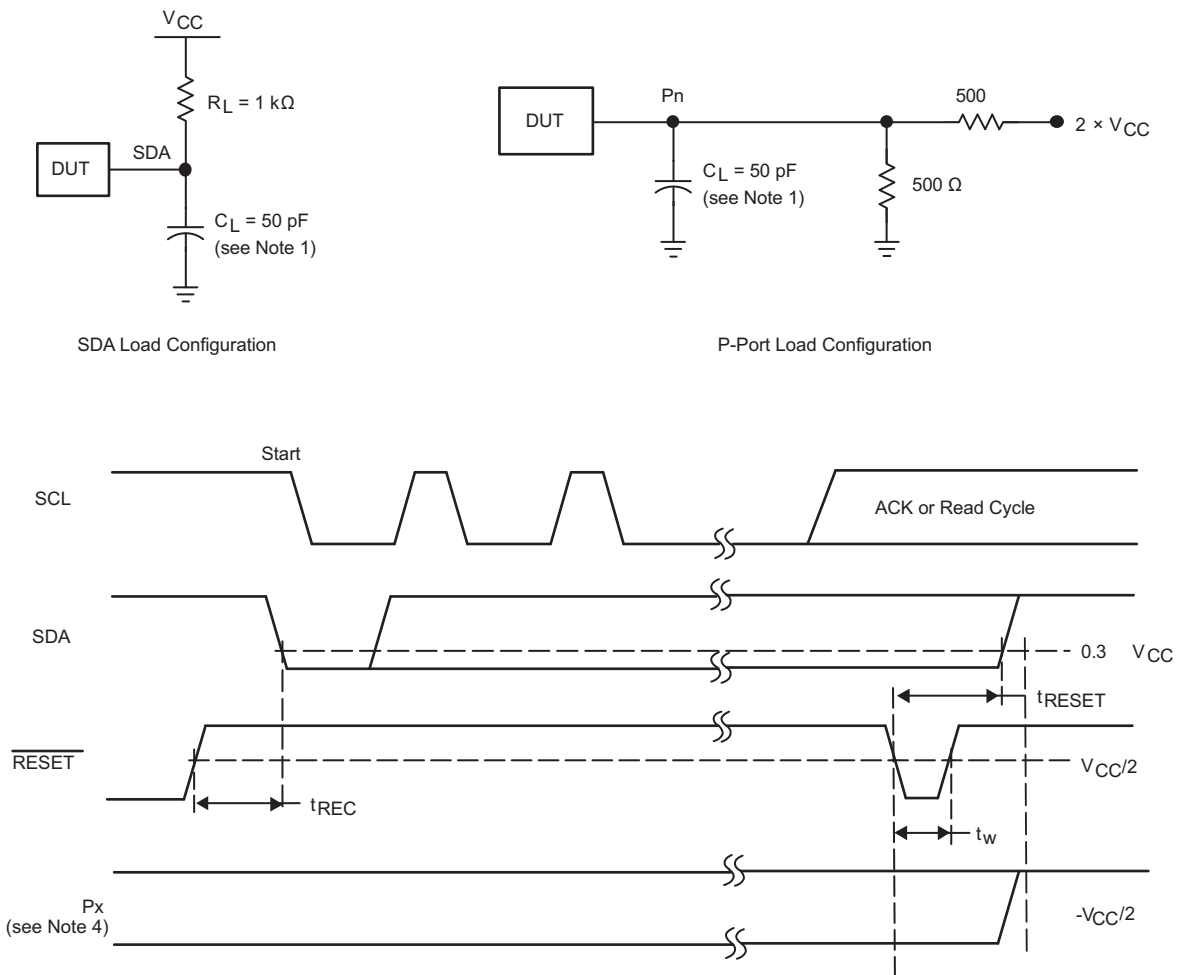

- (1) C_L includes probe and jig capacitance.
- (2) All inputs are supplied by generators having the following characteristics: $PRR \leq 10$ MHz, $Z_O = 50 \Omega$, $t_r/t_f \leq 30$ ns.
- (3) The outputs are measured one at a time, with one transition per measurement.
- (4) I/Os are configured as inputs.
- (5) All parameters and waveforms are not applicable to all devices.

Figure 18. Reset Load Circuits and Voltage Waveforms

8 Detailed Description

8.1 Overview

The TCA9539-Q1 is a 16-bit I/O expander for the two-line bidirectional bus (I²C) designed for 1.65 V to 3.6 V, V_{CC} operation. It provides general-purpose remote I/O expansion for most microcontroller families via the I²C interface, serial clock (SCL) and serial data (SDA).

The TCA9539-Q1 consists of two 8-bit Configuration (input or output selection), Input Port, Output Port, and Polarity Inversion (active-high or active-low operation) registers. At power-on, the I/Os are configured as inputs. The system master can enable the I/Os as either inputs or outputs by writing to the configuration register bits. The data for each input or output is kept in the corresponding Input or output register. The polarity of the Input Port register can be inverted with the Polarity Inversion register. All registers can be read by the system master.

The system master can reset the TCA9539-Q1 in the event of a time-out or other improper operation by asserting a low in the $\overline{\text{RESET}}$ input. The power-on reset puts the registers in their default state and initializes the I²C-SMBus state machine. Asserting $\overline{\text{RESET}}$ causes the same reset-initialization to occur without depowering the part.

The TCA9539-Q1 open-drain interrupt ($\overline{\text{INT}}$) output is activated when any input state differs from its corresponding Input Port register state and is used to indicate to the system master that an input state has changed.

$\overline{\text{INT}}$ can be connected to the interrupt input of a microcontroller. By sending an interrupt signal on this line, the remote I/O can inform the microcontroller if there is incoming data on its ports without having to communicate via the I²C bus. Thus, the TCA9539-Q1 can remain a simple slave device.

The TCA9539-Q1 is similar to the TCA9555, except for the removal of the internal I/O pull-up resistor, which greatly reduces power consumption when the I/Os are held low, replacement of A2 with $\overline{\text{RESET}}$, and a different address range. The TCA9539-Q1 is similar to the PCA9539 with lower voltage support (down to V_{CC} = 1.65 V), and also improved power-on-reset circuitry for different application scenarios.

Two hardware pins (A0 and A1) are used to program and vary the fixed I²C address and allow up to four devices to share the same I²C bus or SMBus.

8.2 Functional Block Diagram

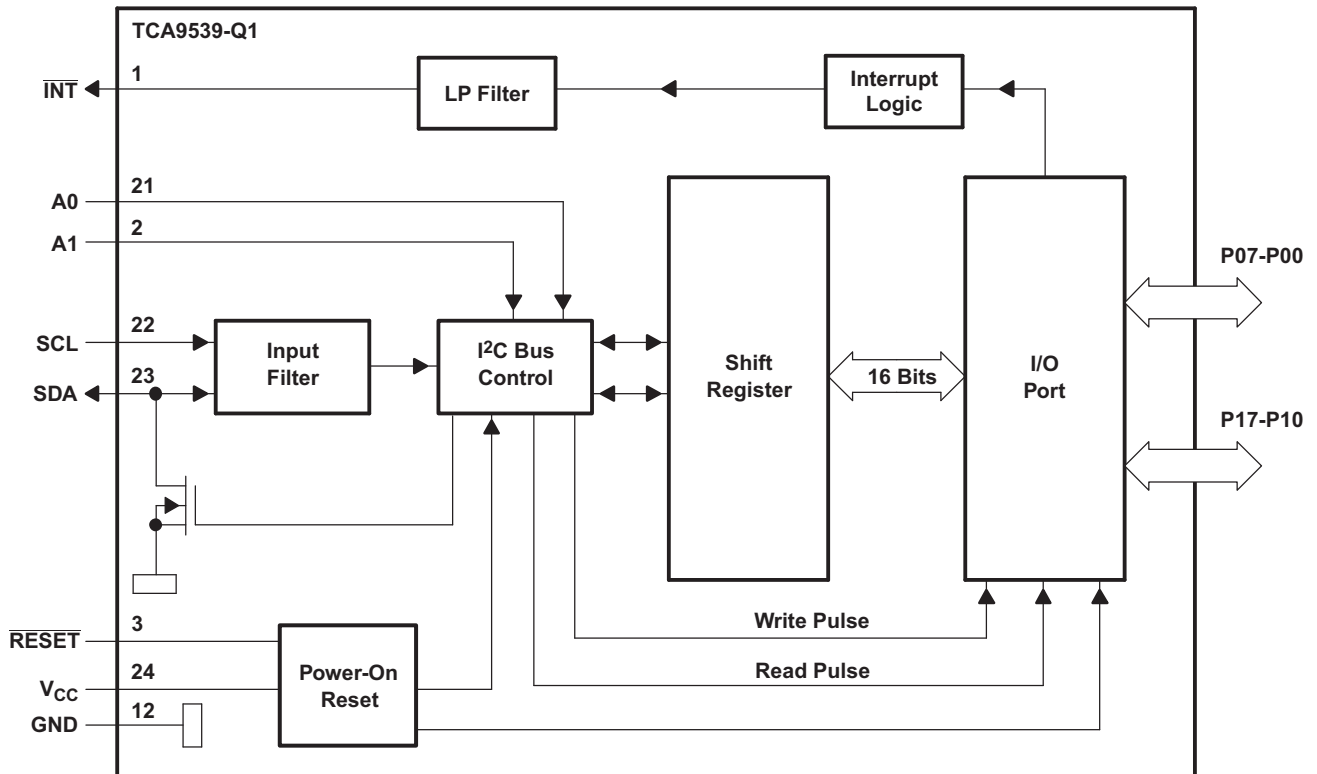

Copyright © 2016, Texas Instruments Incorporated

Pin numbers shown are for PW package.
All I/Os are set to inputs at reset.

Figure 19. Logic Diagram (Positive Logic)

Functional Block Diagram (continued)

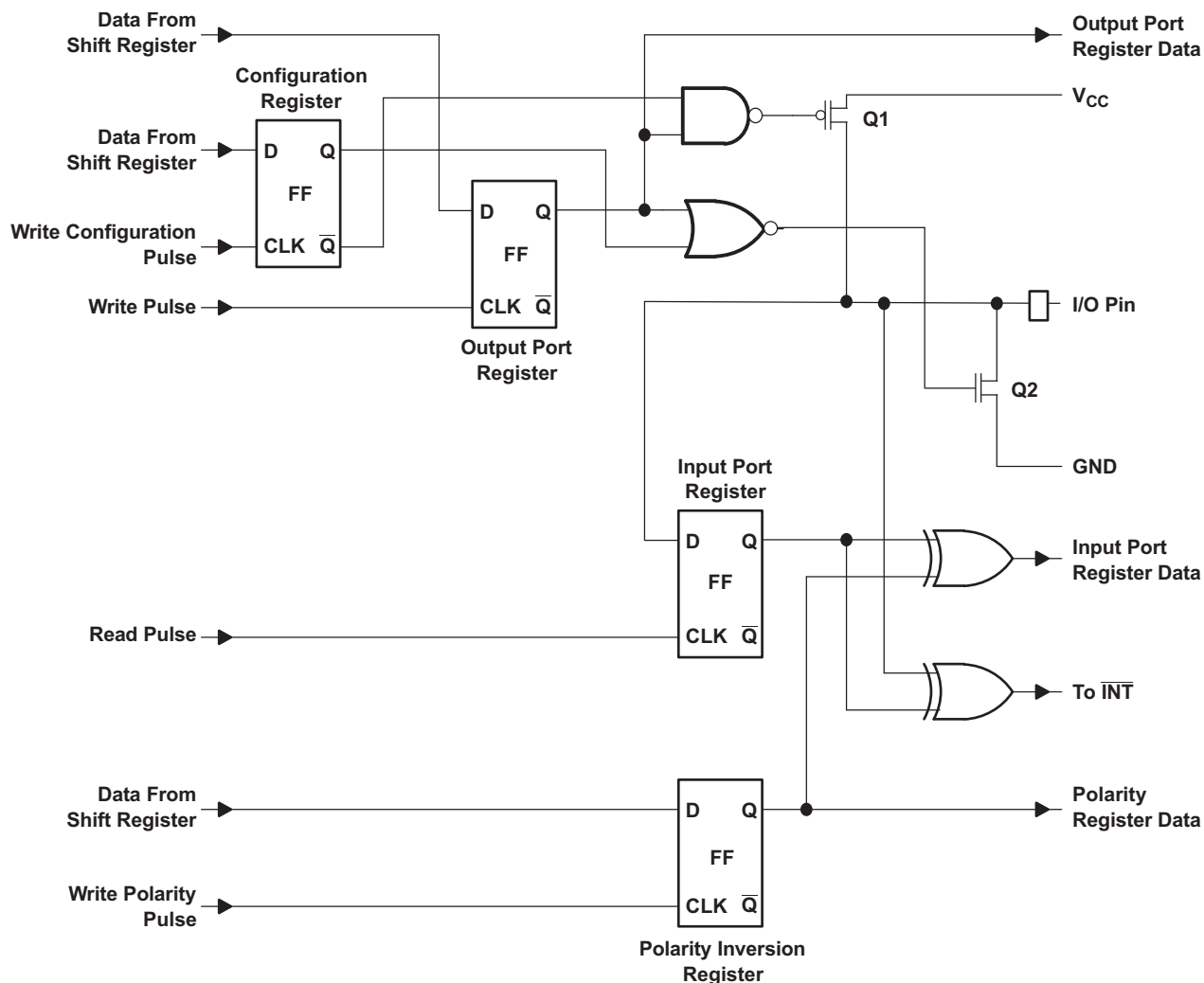

Copyright © 2016, Texas Instruments Incorporated

At power-on reset, all registers return to default values.

Figure 20. Simplified Schematic of P-Port I/Os

8.3 Feature Description

8.3.1 I/O Port

When an I/O is configured as an input, FETs Q1 and Q2 are off, which creates a high-impedance input. The input voltage may be raised above V_{CC} to a maximum of 5.5 V.

If the I/O is configured as an output, Q1 or Q2 is enabled, depending on the state of the Output Port register. In this case, there are low-impedance paths between the I/O pin and either V_{CC} or GND. The external voltage applied to this I/O pin must not exceed the recommended levels for proper operation.

8.3.2 $\overline{\text{RESET}}$ Input

A reset can be accomplished by holding the $\overline{\text{RESET}}$ pin low for a minimum of t_{W} . The TCA9539-Q1 registers and I²C-SMBus state machine are held in their default states until $\overline{\text{RESET}}$ is once again high. This input requires a pull-up resistor to V_{CC} , if no active connection is used.

Feature Description (continued)

8.3.3 Interrupt ($\overline{\text{INT}}$) Output

An interrupt is generated by any rising or falling edge of the port inputs in the input mode. After time, t_{IV} , the signal $\overline{\text{INT}}$ is valid. Resetting the interrupt circuit is achieved when data on the port is changed to the original setting or data is read from the port that generated the interrupt. Resetting occurs in the read mode at the acknowledge (ACK) bit after the rising edge of the SCL signal. Note that the $\overline{\text{INT}}$ is reset at the ACK just before the byte of changed data is sent. Interrupts that occur during the ACK clock pulse can be lost (or be very short) because of the resetting of the interrupt during this pulse. Each change of the I/Os after resetting is detected and is transmitted as $\overline{\text{INT}}$.

Reading from or writing to another device does not affect the interrupt circuit, and a pin configured as an output cannot cause an interrupt. Changing an I/O from an output to an input may cause a false interrupt to occur if the state of the pin does not match the contents of the Input Port register. Because each 8-bit port is read independently, the interrupt caused by port 0 is not cleared by a read of port 1, or vice versa.

$\overline{\text{INT}}$ has an open-drain structure and requires a pull-up resistor to V_{CC} .

8.4 Device Functional Modes

8.4.1 Power-On Reset

When power (from 0 V) is applied to V_{CC} , an internal power-on reset holds the TCA9539-Q1 in a reset condition until V_{CC} has reached V_{PORR} . At that point, the reset condition is released and the TCA9539-Q1 registers and I²C-SMBus state machine initialize to their default states. After that, V_{CC} must be lowered to V_{PORF} and then back up to the operating voltage for a power-reset cycle. See [Figure 21](#).

8.5 Programming

8.5.1 I²C Interface

The TCA9539-Q1 has a standard bidirectional I²C interface that is controlled by a master device in order to be configured or read the status of this device. Each slave on the I²C bus has a specific device address to differentiate between other slave devices that are on the same I²C bus. Many slave devices require configuration upon startup to set the behavior of the device. This is typically done when the master accesses internal register maps of the slave, which have unique register addresses. A device can have one or multiple registers where data is stored, written, or read. For more information see *Understanding the I²C Bus*, [SLVA704](#).

The physical I²C interface consists of the serial clock (SCL) and serial data (SDA) lines. Both SDA and SCL lines must be connected to V_{CC} through a pull-up resistor. The size of the pull-up resistor is determined by the amount of capacitance on the I²C lines. For further details, see *I²C Pull-up Resistor Calculation*, [SLVA689](#). Data transfer may be initiated only when the bus is idle. A bus is considered idle if both SDA and SCL lines are high after a STOP condition. See [Table 1](#).

[Figure 21](#) and [Figure 22](#) show the general procedure for a master to access a slave device:

1. If a master wants to send data to a slave:
 - Master-transmitter sends a START condition and addresses the slave-receiver.
 - Master-transmitter sends data to slave-receiver.
 - Master-transmitter terminates the transfer with a STOP condition.
2. If a master wants to receive or read data from a slave:
 - Master-receiver sends a START condition and addresses the slave-transmitter.
 - Master-receiver sends the requested register to read to slave-transmitter.
 - Master-receiver receives data from the slave-transmitter.

Programming (continued)

- Master-receiver terminates the transfer with a STOP condition.

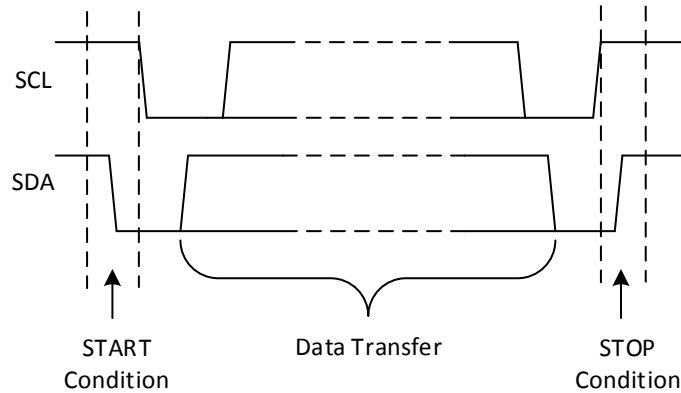

Figure 21. Definition of Start and Stop Conditions

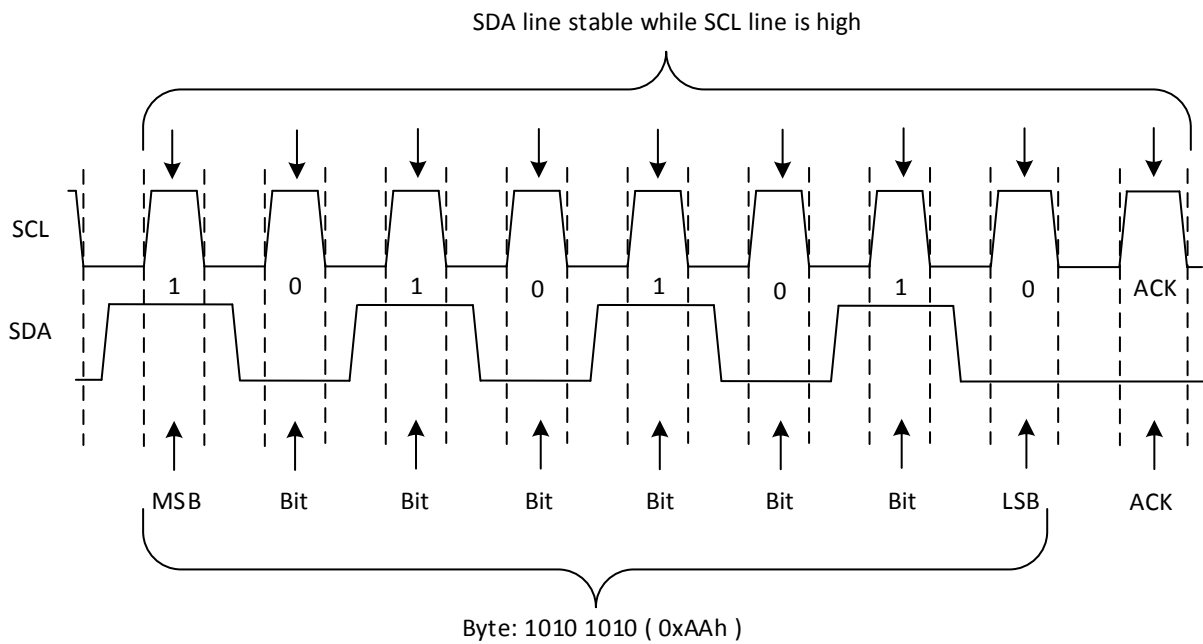

Figure 22. Bit Transfer

Table 1 shows the interface definition.

Table 1. Interface Definition

BYTE	BIT							
	7 (MSB)	6	5	4	3	2	1	0 (LSB)
I ² C slave address	H	H	H	L	H	A1	A0	R \bar{W}
P0x I/O data bus	P07	P06	P05	P04	P03	P02	P01	P00
P1x I/O data bus	P17	P16	P15	P14	P13	P12	P11	P10

8.6 Register Maps

8.6.1 Device Address

Figure 23 shows the address byte of the TCA9539-Q1.

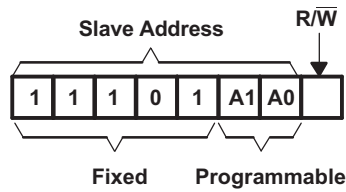

Figure 23. TCA9539-Q1 Address

Table 2 shows the address reference of the TCA9539-Q1.

Table 2. Address Reference

INPUTS		I ² C BUS SLAVE ADDRESS
A1	A0	
L	L	116 (decimal), 74 (hexadecimal)
L	H	117 (decimal), 75 (hexadecimal)
H	L	118 (decimal), 76 (hexadecimal)
H	H	119 (decimal), 77 (hexadecimal)

The last bit of the slave address defines the operation (read or write) to be performed. A high (1) selects a read operation, while a low (0) selects a write operation.

8.6.2 Control Register And Command Byte

Following the successful acknowledgment of the address byte, the bus master sends a command byte shown in Table 3 that is stored in the control register in the TCA9539-Q1. Three bits of this data byte state the operation (read or write) and the internal register (input, output, Polarity Inversion or Configuration) that is affected. This register can be written or read through the I²C bus. The command byte is sent only during a write transmission.

When a command byte has been sent, the register pair that was addressed continues to be accessed by reads until a new command byte has been sent. Figure 24 shows the control register bits.

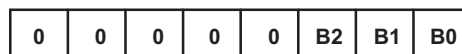

Figure 24. Control Register Bits

Table 3. Command Byte

CONTROL REGISTER BITS			COMMAND BYTE (HEX)	REGISTER	PROTOCOL	POWER-UP DEFAULT
B2	B1	B0				
0	0	0	0x00	Input Port 0	Read byte	xxxx xxxx
0	0	1	0x01	Input Port 1	Read byte	xxxx xxxx
0	1	0	0x02	Output Port 0	Read-write byte	1111 1111
0	1	1	0x03	Output Port 1	Read-write byte	1111 1111
1	0	0	0x04	Polarity Inversion Port 0	Read-write byte	0000 0000
1	0	1	0x05	Polarity Inversion Port 1	Read-write byte	0000 0000
1	1	0	0x06	Configuration Port 0	Read-write byte	1111 1111
1	1	1	0x07	Configuration Port 1	Read-write byte	1111 1111

8.6.3 Register Descriptions

The Input Port registers (registers 0 and 1) shown in [Table 4](#) reflect the incoming logic levels of the pins, regardless of whether the pin is defined as an input or an output by the Configuration register. It only acts on read operation. Writes to these registers have no effect. The default value, X, is determined by the externally applied logic level.

Before a read operation, a write transmission is sent with the command byte to indicate to the I²C device that the Input Port register is accessed next.

Table 4. Registers 0 And 1 (Input Port Registers)

Bit	I0.7	I0.6	I0.5	I0.4	I0.3	I0.2	I0.1	I0.0
Default	X	X	X	X	X	X	X	X
Bit	I1.7	I1.6	I1.5	I1.4	I1.3	I1.2	I1.1	I1.0
Default	X	X	X	X	X	X	X	X

The Output Port registers (registers 2 and 3) shown in [Table 5](#) show the outgoing logic levels of the pins defined as outputs by the Configuration register. Bit values in this register have no effect on pins defined as inputs. In turn, reads from this register reflect the value that is in the flip-flop controlling the output selection, not the actual pin value.

Table 5. Registers 2 And 3 (Output Port Registers)

Bit	O0.7	O0.6	O0.5	O0.4	O0.3	O0.2	O0.1	O0.0
Default	1	1	1	1	1	1	1	1
Bit	O1.7	O1.6	O1.5	O1.4	O1.3	O1.2	O1.1	O1.0
Default	1	1	1	1	1	1	1	1

The Polarity Inversion registers (registers 4 and 5) shown in [Table 6](#) allow Polarity Inversion of pins defined as inputs by the Configuration register. If a bit in this register is set (written with 1), the corresponding port pin's polarity is inverted. If a bit in this register is cleared (written with a 0), the corresponding port pin's original polarity is retained.

Table 6. Registers 4 And 5 (Polarity Inversion Registers)

Bit	N0.7	N0.6	N0.5	N0.4	N0.3	N0.2	N0.1	N0.0
Default	0	0	0	0	0	0	0	0
Bit	N1.7	N1.6	N1.5	N1.4	N1.3	N1.2	N1.1	N1.0
Default	0	0	0	0	0	0	0	0

The Configuration registers (registers 6 and 7) shown in [Table 7](#) configure the directions of the I/O pins. If a bit in this register is set to 1, the corresponding port pin is enabled as an input with a high-impedance output driver. If a bit in this register is cleared to 0, the corresponding port pin is enabled as an output.

Table 7. Registers 6 And 7 (Configuration Registers)

Bit	C0.7	C0.6	C0.5	C0.4	C0.3	C0.2	C0.1	C0.0
Default	1	1	1	1	1	1	1	1
Bit	C1.7	C1.6	C1.5	C1.4	C1.3	C1.2	C1.1	C1.0
Default	1	1	1	1	1	1	1	1

8.6.3.1 Bus Transactions

Data is exchanged between the master and the TCA9539-Q1 through write and read commands, and this is accomplished by reading from or writing to registers in the slave device.

Registers are locations in the memory of the slave which contain information, whether it be the configuration information or some sampled data to send back to the master. The master must write information to these registers in order to instruct the slave device to perform a task.

8.6.3.1.1 Writes

To write on the I²C bus, the master sends a START condition on the bus with the address of the slave, as well as the last bit (the R/ \bar{W} bit) set to 0, which signifies a write. After the slave sends the acknowledge bit, the master then sends the register address of the register to which it wishes to write. The slave acknowledges again, letting the master know it is ready. After this, the master starts sending the register data to the slave until the master has sent all the data necessary (which is sometimes only a single byte), and the master terminates the transmission with a STOP condition.

See the [Control Register And Command Byte](#) section to see list of the TCA9539-Q1s internal registers and a description of each one.

Figure 25 shows an example of writing a single byte to a slave register.

- Master controls SDA line
- Slave controls SDA line

Write to one register in a device

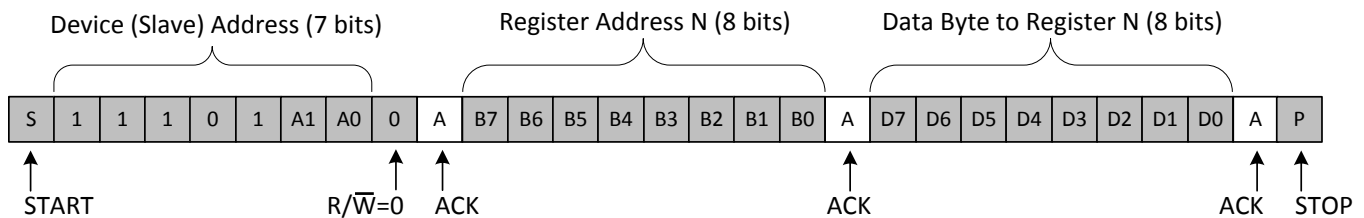

Figure 25. Write to Register

Figure 27 shows the Write to the Polarity Inversion Register.

- Master controls SDA line
- Slave controls SDA line

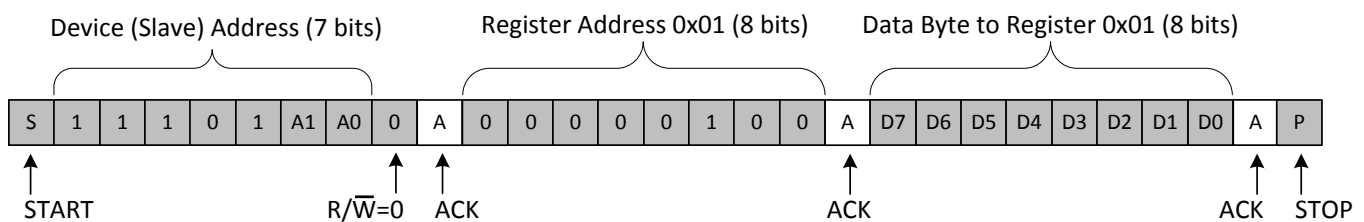

Figure 26. Write to the Polarity Inversion Register

Figure 27 shows the Write to Output Port Registers

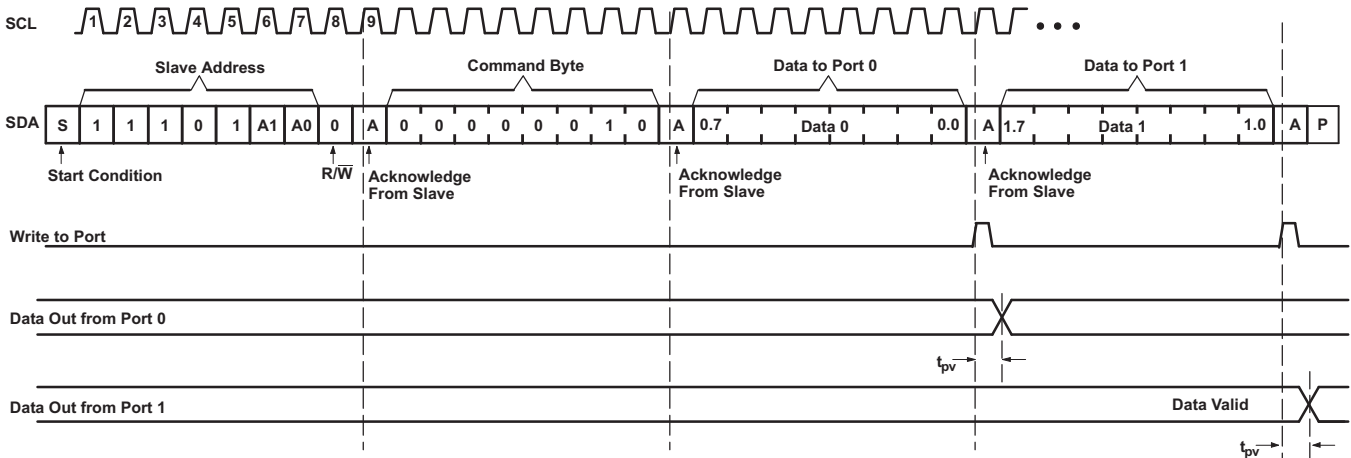

Figure 27. Write to Output Port Registers

8.6.3.1.2 Reads

Reading from a slave is very similar to writing, but requires some additional steps. In order to read from a slave, the master must first instruct the slave which register it wishes to read from. This is done by the master starting off the transmission in a similar fashion as the write, by sending the address with the R/W bit equal to 0 (signifying a write), followed by the register address it wishes to read from. When the slave acknowledges this register address, the master sends a START condition again, followed by the slave address with the R/W bit set to 1 (signifying a read). This time, the slave acknowledges the read request, and the master releases the SDA bus but continues supplying the clock to the slave. During this part of the transaction, the master becomes the master-receiver, and the slave becomes the slave-transmitter.

The master continues to send out the clock pulses, but releases the SDA line so that the slave can transmit data. At the end of every byte of data, the master sends an ACK to the slave, letting the slave know that it is ready for more data. When the master has received the number of bytes it is expecting, it sends a NACK, signaling to the slave to halt communications and release the bus. The master follows this up with a STOP condition.

If a read is requested by the master after a POR without first setting the command byte via a write, the device NACKs until a command byte-register address is set as described above.

See the [Control Register And Command Byte](#) section to see list of the TCA9539-Q1s internal registers and a description of each one.

Figure 28 shows an example of reading a single byte from a slave register.

- Master controls SDA line
- Slave controls SDA line

Read from one register in a device

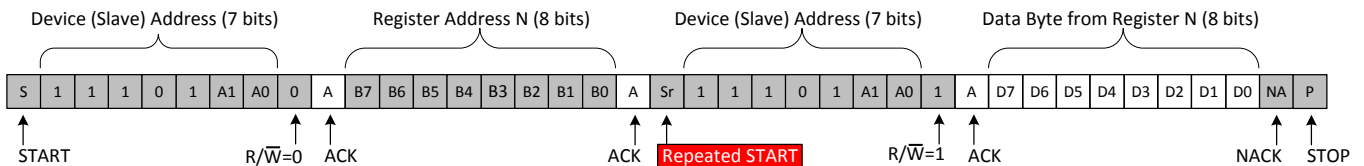
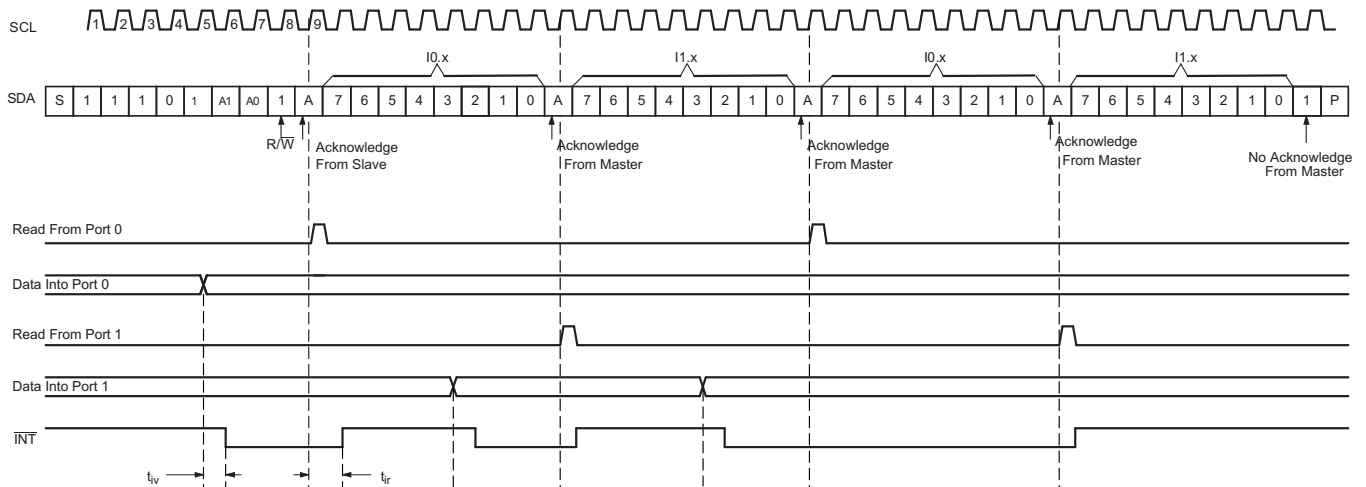

Figure 28. Read from Register

When a restart occurs after a single write request to a register, the requested register is used for the read request. Note that when reading multiple bytes of data. Data is clocked into the register on the rising edge of the ACK clock pulse before data is sent. The internal register value is also changed to the other register of the pair on the rising edge of the ACK clock pulse before data is sent. After the first byte is read, additional bytes may be read, but the data now reflect the information in the other register in the pair. For example, if Input Port 1 is read, the next byte read is Input Port 0. If a restart occurs during a read, the data is lost because the internal register already has been changed to the next register in the pair.

There is no limitation on the number of data bytes received in one read transmission, but when the final byte is received, the bus master must not acknowledge the data. [Figure 29](#) and [Figure 30](#) show two different scenarios of Read Input Port Register.



Transfer of data can be stopped at any time by a Stop condition. When this occurs, data present at the latest acknowledge phase is valid (output mode). It is assumed that the command byte previously has been set to 00 (Read Input Port register).

This figure eliminates the command byte transfer, a restart, and slave address call between the initial slave address call and actual data transfer from the P port (see the [Reads](#) section for these details).

Figure 29. Read Input Port Register, Scenario 1

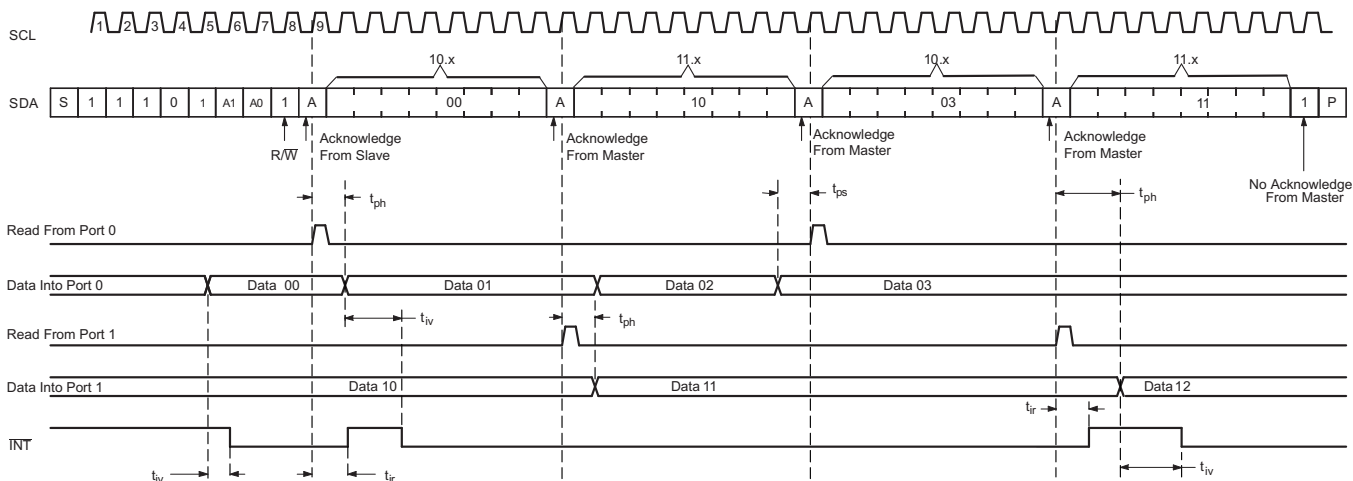

Transfer of data can be stopped at any time by a Stop condition. When this occurs, data present at the latest acknowledge phase is valid (output mode). It is assumed that the command byte previously has been set to 00 (Read Input Port register).

This figure eliminates the command byte transfer, a restart, and slave address call between the initial slave address call and actual data transfer from the P port (see the [Reads](#) section for these details).

Figure 30. Read Input Port Register, Scenario 2

9 Application and Implementation

NOTE

Information in the following applications sections is not part of the TI component specification, and TI does not warrant its accuracy or completeness. TI's customers are responsible for determining suitability of components for their purposes. Customers should validate and test their design implementation to confirm system functionality.

9.1 Application Information

Applications of the TCA9539-Q1 has this device connected as a slave to an I²C master (processor), and the I²C bus may contain any number of other slave devices. The TCA9539-Q1 is typically in a remote location from the master, placed close to the GPIOs to which the master needs to monitor or control.

IO Expanders such as the TCA9539-Q1 are typically used for controlling LEDs (for feedback or status lights), controlling enable or reset signals of other devices, and even reading the outputs of other devices or buttons.

9.2 Typical Application

Figure 31 shows an application in which the TCA9539-Q1 can be used.

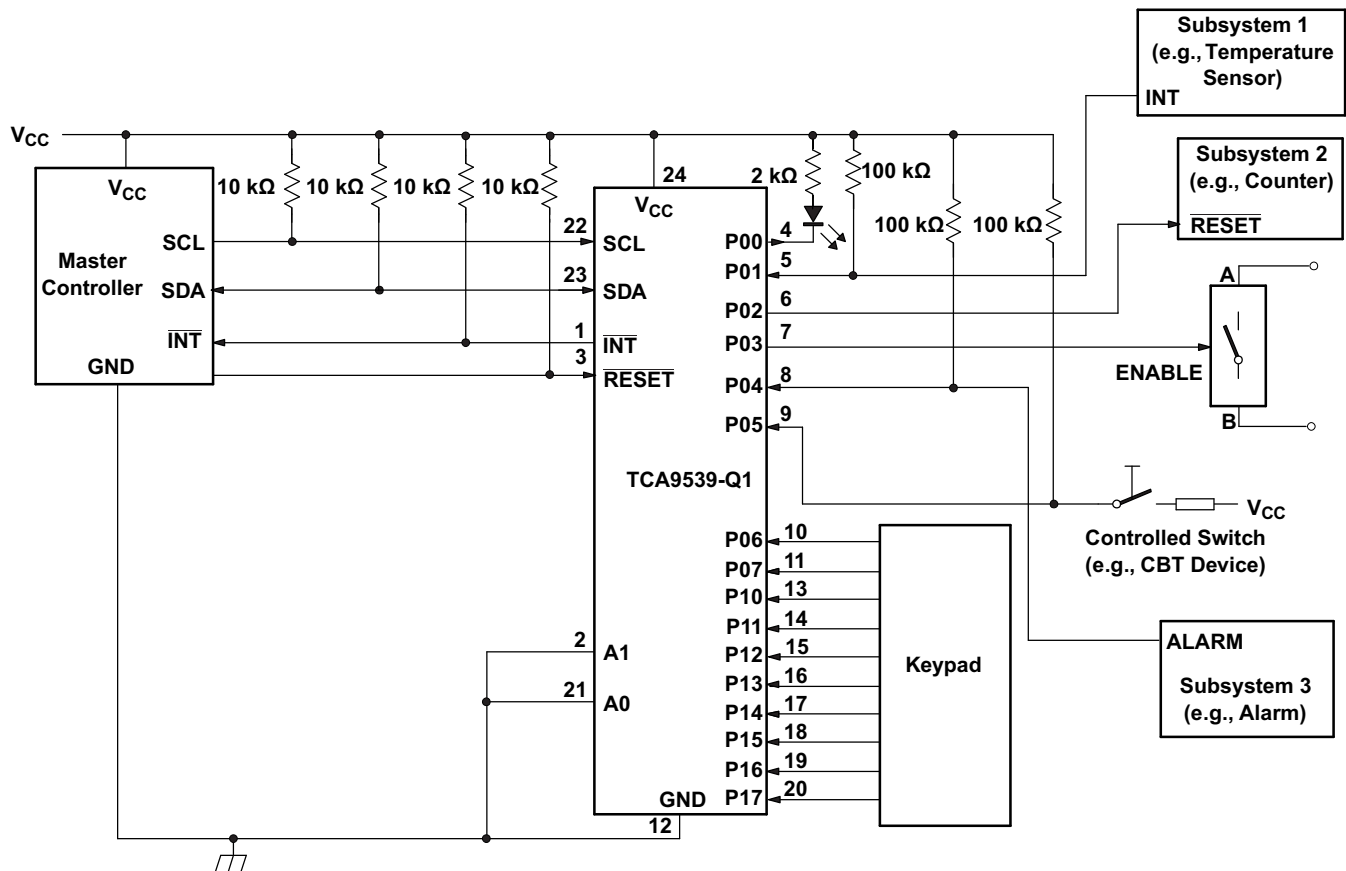

Copyright © 2016, Texas Instruments Incorporated

Device address is configured as 1110100 for this example.

P00, P02, and P03 are configured as outputs.

P01 and P04 to P17 are configured as inputs.

Pin numbers shown are for the PW package.

Figure 31. Application Schematic

Typical Application (continued)

9.2.1 Design Requirements

9.2.1.1 Calculating Junction Temperature and Power Dissipation

When designing with the TCA9539-Q1, it is important that the *Recommended Operating Conditions* not be violated. Many of the parameters of this device are rated based on junction temperature. So junction temperature must be calculated in order to verify that safe operation of the device is met. The basic equation for junction temperature is shown in Equation 1.

$$T_j = T_A + (\theta_{JA} \times P_d) \quad (1)$$

θ_{JA} is the standard junction to ambient thermal resistance measurement of the package, as seen in *Thermal Information* table. P_d is the total power dissipation of the device, and the approximation is shown in Equation 2.

$$P_d \approx (I_{CC_STATIC} \times V_{CC}) + \sum P_{d_PORT_L} + \sum P_{d_PORT_H} \quad (2)$$

Equation 2 is the approximation of power dissipation in the device. The equation is the static power plus the summation of power dissipated by each port (with a different equation based on if the port is outputting high, or outputting low. If the port is set as an input, then power dissipation is the input leakage of the pin multiplied by the voltage on the pin). Note that this ignores power dissipation in the \overline{INT} and SDA pins, assuming these transients to be small. They can easily be included in the power dissipation calculation by using Equation 3 to calculate the power dissipation in \overline{INT} or SDA while they are pulling low, and this gives maximum power dissipation.

$$P_{d_PORT_L} = (I_{OL} \times V_{OL}) \quad (3)$$

Equation 3 shows the power dissipation for a single port which is set to output low. The power dissipated by the port is the V_{OL} of the port multiplied by the current it is sinking.

$$P_{d_PORT_H} = (I_{OH} \times (V_{CC} - V_{OH})) \quad (4)$$

Equation 4 shows the power dissipation for a single port which is set to output high. The power dissipated by the port is the current sourced by the port multiplied by the voltage drop across the device (difference between V_{CC} and the output voltage).

9.2.1.2 Minimizing I_{CC} When I/Os Control LEDs

When an I/O is used to control an LED, normally it is connected to V_{CC} through a resistor (see Figure 31). Because the LED acts as a diode, when the LED is off, the I/O V_{IN} is about 1.2 V less than V_{CC} . The ΔI_{CC} parameter in the *Electrical Characteristics* table show how I_{CC} increases as V_{IN} becomes lower than V_{CC} . For battery-powered applications, it is essential that the voltage of I/O pins is greater than or equal to V_{CC} , when the LED is off, to minimize current consumption.

Figure 32 shows a high-value resistor in parallel with the LED. Figure 33 shows V_{CC} less than the LED supply voltage by at least 1.2 V. Both of these methods maintain the I/O V_{CC} at or above V_{CC} and prevent additional supply-current consumption when the LED is off.

Take care to make sure that the recommended maximum I_{OL} through the ports not be violated based upon junction temperature. See the *Recommended Operating Conditions* for more information.

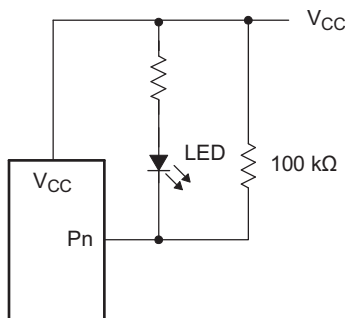

Figure 32. High-Value Resistor In Parallel With LED

Typical Application (continued)

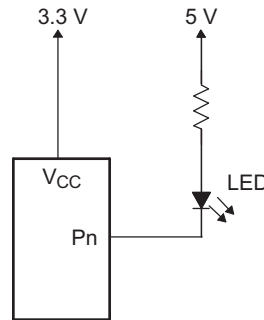

Figure 33. Device Supplied By Lower Voltage

9.2.2 Detailed Design Procedure

The pull-up resistors, R_p , for the SCL and SDA lines need to be selected appropriately and take into consideration the total capacitance of all slaves on the I²C bus. The minimum pull-up resistance is a function of V_{CC} , $V_{OL(max)}$, and I_{OL} as shown in Equation 5.

$$R_{p(min)} = \frac{V_{CC} - V_{OL(max)}}{I_{OL}} \tag{5}$$

The maximum pull-up resistance is a function of the maximum rise time, t_r (300 ns for fast-mode operation, $f_{SCL} = 400$ kHz) and bus capacitance, C_b as shown in Equation 6.

$$R_{p(max)} = \frac{t_r}{0.8473 \times C_b} \tag{6}$$

The maximum bus capacitance for an I²C bus must not exceed 400 pF for standard-mode or fast-mode operation. The bus capacitance can be approximated by adding the capacitance of the TCA9539-Q1, C_i for SCL or C_{io} for SDA, the capacitance of wires, connections, traces, and the capacitance of additional slaves on the bus.

9.2.3 Application Curves

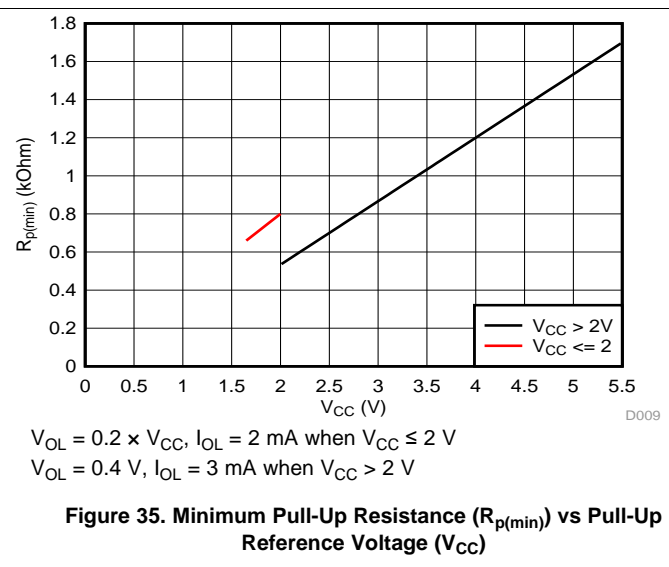
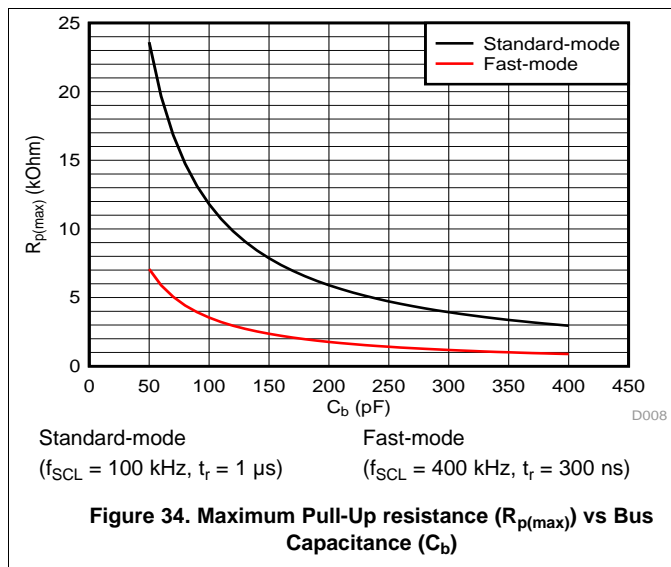

10 Power Supply Recommendations

10.1 Power-On Reset Requirements

In the event of a glitch or data corruption, TCA9539-Q1 can be reset to its default conditions by using the power-on reset feature. Power-on reset requires that the device go through a power cycle to be completely reset. This reset also happens when the device is powered on for the first time in an application.

The voltage waveform for a power-on reset is shown in Figure 36.

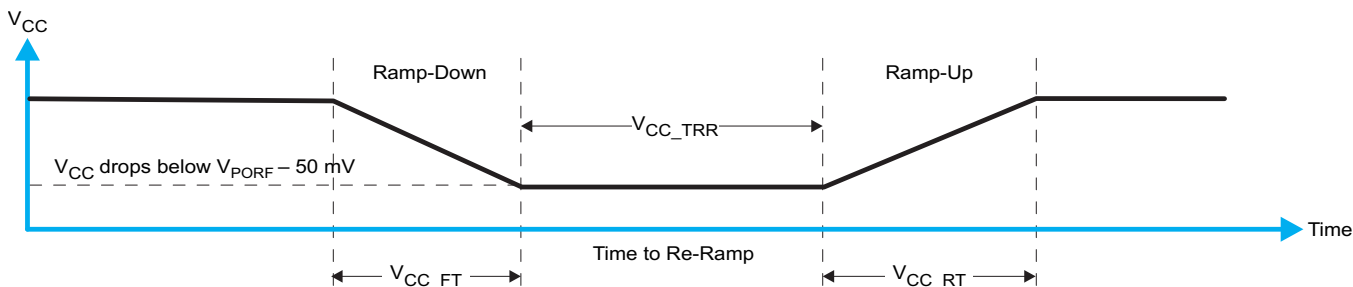

Figure 36. V_{CC} is Lowered Below the POR Threshold, then Ramped Back Up to V_{CC}

Table 8 specifies the performance of the power-on reset feature for TCA9539-Q1.

Table 8. Recommended Supply Sequencing And Ramp Rates ⁽¹⁾

PARAMETER		MIN	TYP	MAX	UNIT	
V_{CC_FT}	Fall rate	See Figure 36	0.1		ms	
V_{CC_RT}	Rise rate	See Figure 36	0.1		ms	
V_{CC_TRR}	Time to re-ramp (when V_{CC} drops to $V_{POR_MIN} - 50$ mV or when V_{CC} drops to GND)	See Figure 36	2		μ s	
V_{CC_GH}	The level (referenced to V_{CC}) that V_{CC} can glitch down to, but not cause a functional disruption when V_{CC_GW}	See Figure 37		1.2	V	
V_{CC_MV}	The minimum voltage that V_{CC} can glitch down to without causing a reset (V_{CC_GH} must not be violated)	See Figure 37	1.5		V	
V_{CC_GW}	Glitch width that does not cause a functional disruption	See Figure 37		10	μ s	
V_{PORF}	Voltage trip point of POR on falling V_{CC}		0.75	1	V	
V_{PORR}	Voltage trip point of POR on rising V_{CC}			1.2	1.5	V

(1) $T_A = -40^{\circ}\text{C}$ to $+125^{\circ}\text{C}$ (unless otherwise noted)

Glitches in the power supply can also affect the power-on reset performance of this device. The glitch width (V_{CC_GW}) and height (V_{CC_GH}) are dependent on each other. The bypass capacitance, source impedance, and device impedance are factors that affect power-on reset performance. Figure 37 and Table 8 provide more information on how to measure these specifications.

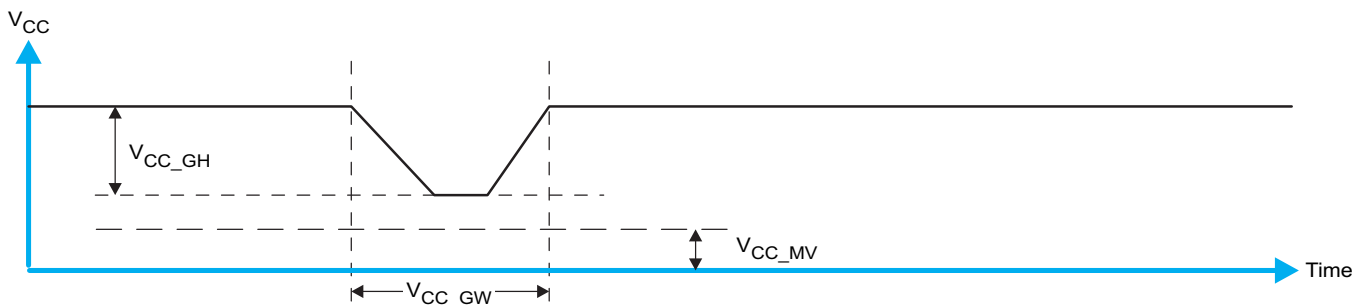

Figure 37. Glitch Width, Glitch Height, and Minimum Glitch Voltage

V_{POR} is critical to the power-on reset. V_{PORR} is the voltage level at which the reset condition is released and all the registers and the I²C/SMBus state machine are initialized to their default states. The value of V_{POR} differs based on the V_{CC} being lowered to or from 0. [Figure 38](#) and [Table 8](#) provide more details on this specification.

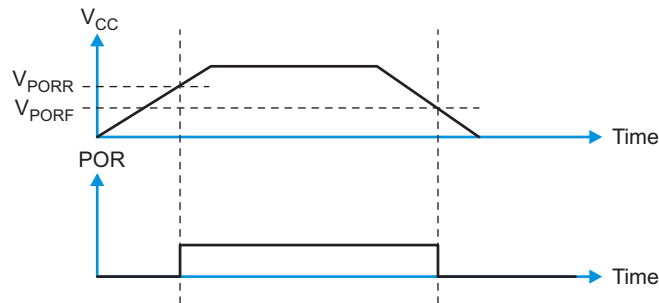

Figure 38. V_{POR}

11 Layout

11.1 Layout Guidelines

For printed circuit board (PCB) layout of the TCA9539-Q1, common PCB layout practices must be followed but additional concerns related to high-speed data transfer such as matched impedances and differential pairs are not a concern for I²C signal speeds.

In all PCB layouts, it is a best practice to avoid right angles in signal traces, to fan out signal traces away from each other upon leaving the vicinity of an integrated circuit (IC), and to use thicker trace widths to carry higher amounts of current that commonly pass through power and ground traces. By-pass and de-coupling capacitors are commonly used to control the voltage on the V_{CC} pin, using a larger capacitor to provide additional power in the event of a short power supply glitch and a smaller capacitor to filter out high-frequency ripple. These capacitors must be placed as close to the TCA9539-Q1 as possible. These best practices are shown in [Figure 39](#).

For the layout example provided in [Figure 39](#), it would be possible to fabricate a PCB with only 2 layers by using the top layer for signal routing and the bottom layer as a split plane for power (V_{CC}) and ground (GND). However, a 4 layer board is preferable for boards with higher density signal routing. On a 4 layer PCB, it is common to route signals on the top and bottom layer, dedicate one internal layer to a ground plane, and dedicate the other internal layer to a power plane. In a board layout using planes or split planes for power and ground, vias are placed directly next to the surface mount component pad which must attach to V_{CC} or GND and the via is connected electrically to the internal layer or the other side of the board. Vias are also used when a signal trace needs to be routed to the opposite side of the board, but this technique is not demonstrated in [Figure 39](#).

11.2 Layout Example

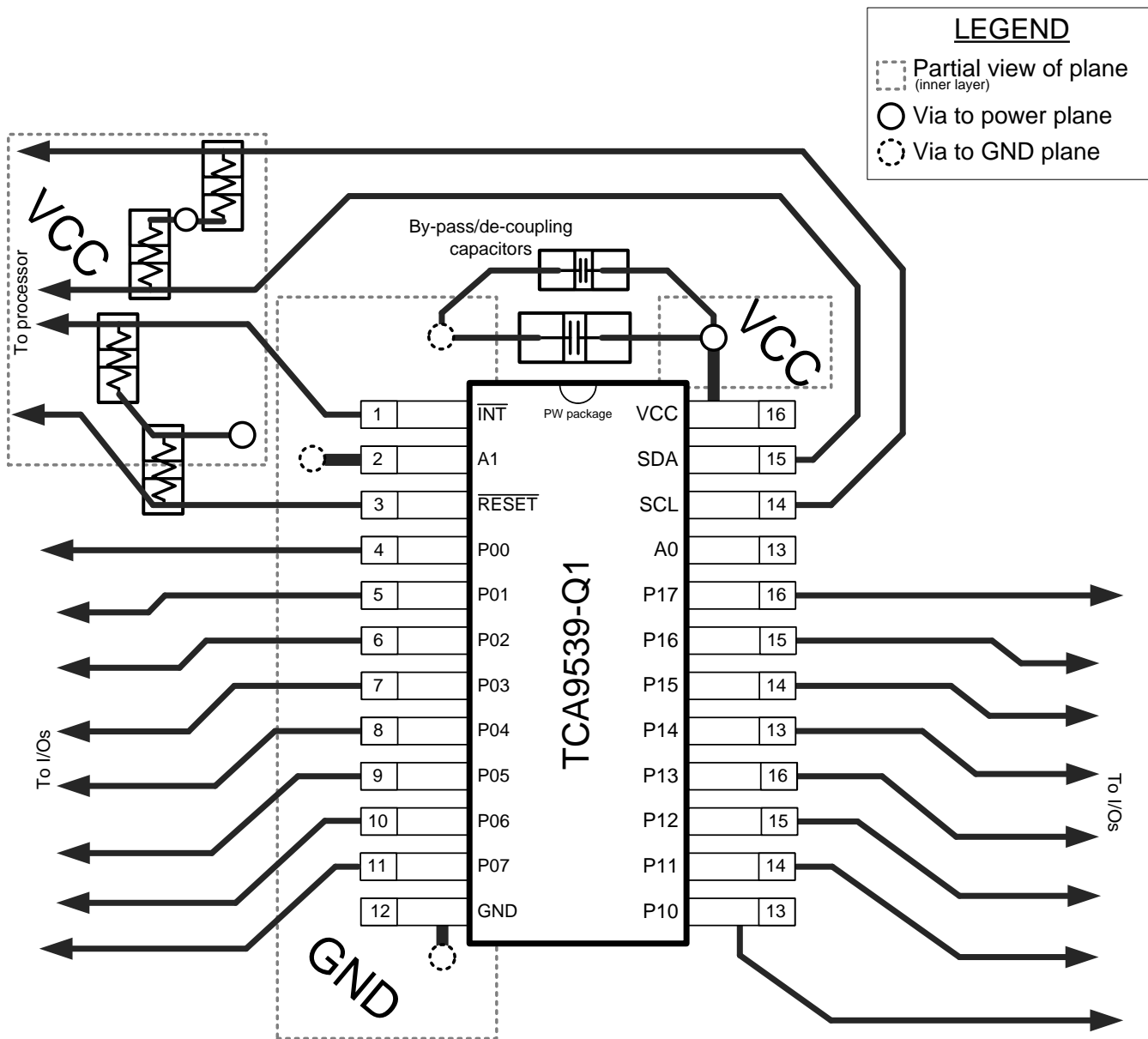

Figure 39. TCA9539-Q1 Layout

12 Device and Documentation Support

12.1 Documentation Support

12.1.1 Related Documentation

For related documentation see the following:

- *Understanding the I2C Bus*, [SLVA704](#)
- *I2C Pull-up Resistor Calculation*, [SLVA689](#)
- *Introduction to Logic*, [SLVA700](#)
- *Maximum Clock Frequency of I2C Bus Using Repeaters*, [SLVA695](#)
- *I2C Bus Pull-Up Resistor Calculation*, [SLVA689](#)

12.2 Receiving Notification of Documentation Updates

To receive notification of documentation updates, navigate to the device product folder on ti.com. In the upper right corner, click on *Alert me* to register and receive a weekly digest of any product information that has changed. For change details, review the revision history included in any revised document.

12.3 Community Resources

The following links connect to TI community resources. Linked contents are provided "AS IS" by the respective contributors. They do not constitute TI specifications and do not necessarily reflect TI's views; see TI's [Terms of Use](#).

TI E2E™ Online Community *TI's Engineer-to-Engineer (E2E) Community*. Created to foster collaboration among engineers. At e2e.ti.com, you can ask questions, share knowledge, explore ideas and help solve problems with fellow engineers.

Design Support *TI's Design Support* Quickly find helpful E2E forums along with design support tools and contact information for technical support.

12.4 Trademarks

E2E is a trademark of Texas Instruments. All other trademarks are the property of their respective owners.

12.5 Electrostatic Discharge Caution



These devices have limited built-in ESD protection. The leads should be shorted together or the device placed in conductive foam during storage or handling to prevent electrostatic damage to the MOS gates.

12.6 Glossary

[SLYZ022](#) — *TI Glossary*.

This glossary lists and explains terms, acronyms, and definitions.

13 Mechanical, Packaging, and Orderable Information

The following pages include mechanical, packaging, and orderable information. This information is the most current data available for the designated devices. This data is subject to change without notice and revision of this document. For browser-based versions of this data sheet, refer to the left-hand navigation.

PACKAGING INFORMATION

Orderable Device	Status (1)	Package Type	Package Drawing	Pins	Package Qty	Eco Plan (2)	Lead/Ball Finish (6)	MSL Peak Temp (3)	Op Temp (°C)	Device Marking (4/5)	Samples
TCA9539QPWRQ1	ACTIVE	TSSOP	PW	24	2000	Green (RoHS & no Sb/Br)	CU NIPDAU	Level-1-260C-UNLIM	-40 to 125	TCA539Q	Samples

(1) The marketing status values are defined as follows:

ACTIVE: Product device recommended for new designs.

LIFEBUY: TI has announced that the device will be discontinued, and a lifetime-buy period is in effect.

NRND: Not recommended for new designs. Device is in production to support existing customers, but TI does not recommend using this part in a new design.

PREVIEW: Device has been announced but is not in production. Samples may or may not be available.

OBSOLETE: TI has discontinued the production of the device.

(2) **RoHS:** TI defines "RoHS" to mean semiconductor products that are compliant with the current EU RoHS requirements for all 10 RoHS substances, including the requirement that RoHS substance do not exceed 0.1% by weight in homogeneous materials. Where designed to be soldered at high temperatures, "RoHS" products are suitable for use in specified lead-free processes. TI may reference these types of products as "Pb-Free".

RoHS Exempt: TI defines "RoHS Exempt" to mean products that contain lead but are compliant with EU RoHS pursuant to a specific EU RoHS exemption.

Green: TI defines "Green" to mean the content of Chlorine (Cl) and Bromine (Br) based flame retardants meet JS709B low halogen requirements of <=1000ppm threshold. Antimony trioxide based flame retardants must also meet the <=1000ppm threshold requirement.

(3) MSL, Peak Temp. - The Moisture Sensitivity Level rating according to the JEDEC industry standard classifications, and peak solder temperature.

(4) There may be additional marking, which relates to the logo, the lot trace code information, or the environmental category on the device.

(5) Multiple Device Markings will be inside parentheses. Only one Device Marking contained in parentheses and separated by a "~" will appear on a device. If a line is indented then it is a continuation of the previous line and the two combined represent the entire Device Marking for that device.

(6) Lead/Ball Finish - Orderable Devices may have multiple material finish options. Finish options are separated by a vertical ruled line. Lead/Ball Finish values may wrap to two lines if the finish value exceeds the maximum column width.

Important Information and Disclaimer:The information provided on this page represents TI's knowledge and belief as of the date that it is provided. TI bases its knowledge and belief on information provided by third parties, and makes no representation or warranty as to the accuracy of such information. Efforts are underway to better integrate information from third parties. TI has taken and continues to take reasonable steps to provide representative and accurate information but may not have conducted destructive testing or chemical analysis on incoming materials and chemicals. TI and TI suppliers consider certain information to be proprietary, and thus CAS numbers and other limited information may not be available for release.

In no event shall TI's liability arising out of such information exceed the total purchase price of the TI part(s) at issue in this document sold by TI to Customer on an annual basis.

OTHER QUALIFIED VERSIONS OF TCA9539-Q1 :

- Catalog: [TCA9539](#)

NOTE: Qualified Version Definitions:

- Catalog - TI's standard catalog product

TAPE AND REEL INFORMATION



QUADRANT ASSIGNMENTS FOR PIN 1 ORIENTATION IN TAPE



*All dimensions are nominal

Device	Package Type	Package Drawing	Pins	SPQ	Reel Diameter (mm)	Reel Width W1 (mm)	A0 (mm)	B0 (mm)	K0 (mm)	P1 (mm)	W (mm)	Pin1 Quadrant
TCA9539QPWRQ1	TSSOP	PW	24	2000	330.0	16.4	6.95	8.3	1.6	8.0	16.0	Q1

TAPE AND REEL BOX DIMENSIONS

*All dimensions are nominal

Device	Package Type	Package Drawing	Pins	SPQ	Length (mm)	Width (mm)	Height (mm)
TCA9539QPWRQ1	TSSOP	PW	24	2000	367.0	367.0	38.0

PW0024A



PACKAGE OUTLINE

TSSOP - 1.2 mm max height

SMALL OUTLINE PACKAGE



4220208/A 02/2017

NOTES:

1. All linear dimensions are in millimeters. Any dimensions in parenthesis are for reference only. Dimensioning and tolerancing per ASME Y14.5M.
2. This drawing is subject to change without notice.
3. This dimension does not include mold flash, protrusions, or gate burrs. Mold flash, protrusions, or gate burrs shall not exceed 0.15 mm per side.
4. This dimension does not include interlead flash. Interlead flash shall not exceed 0.25 mm per side.
5. Reference JEDEC registration MO-153.

EXAMPLE BOARD LAYOUT

PW0024A

TSSOP - 1.2 mm max height

SMALL OUTLINE PACKAGE



LAND PATTERN EXAMPLE
EXPOSED METAL SHOWN
SCALE: 10X



SOLDER MASK DETAILS

4220208/A 02/2017

NOTES: (continued)

- 6. Publication IPC-7351 may have alternate designs.
- 7. Solder mask tolerances between and around signal pads can vary based on board fabrication site.

EXAMPLE STENCIL DESIGN

PW0024A

TSSOP - 1.2 mm max height

SMALL OUTLINE PACKAGE



NOTES: (continued)

8. Laser cutting apertures with trapezoidal walls and rounded corners may offer better paste release. IPC-7525 may have alternate design recommendations.
9. Board assembly site may have different recommendations for stencil design.

IMPORTANT NOTICE AND DISCLAIMER

TI PROVIDES TECHNICAL AND RELIABILITY DATA (INCLUDING DATASHEETS), DESIGN RESOURCES (INCLUDING REFERENCE DESIGNS), APPLICATION OR OTHER DESIGN ADVICE, WEB TOOLS, SAFETY INFORMATION, AND OTHER RESOURCES "AS IS" AND WITH ALL FAULTS, AND DISCLAIMS ALL WARRANTIES, EXPRESS AND IMPLIED, INCLUDING WITHOUT LIMITATION ANY IMPLIED WARRANTIES OF MERCHANTABILITY, FITNESS FOR A PARTICULAR PURPOSE OR NON-INFRINGEMENT OF THIRD PARTY INTELLECTUAL PROPERTY RIGHTS.

These resources are intended for skilled developers designing with TI products. You are solely responsible for (1) selecting the appropriate TI products for your application, (2) designing, validating and testing your application, and (3) ensuring your application meets applicable standards, and any other safety, security, or other requirements. These resources are subject to change without notice. TI grants you permission to use these resources only for development of an application that uses the TI products described in the resource. Other reproduction and display of these resources is prohibited. No license is granted to any other TI intellectual property right or to any third party intellectual property right. TI disclaims responsibility for, and you will fully indemnify TI and its representatives against, any claims, damages, costs, losses, and liabilities arising out of your use of these resources.

TI's products are provided subject to TI's Terms of Sale (www.ti.com/legal/termsofsale.html) or other applicable terms available either on ti.com or provided in conjunction with such TI products. TI's provision of these resources does not expand or otherwise alter TI's applicable warranties or warranty disclaimers for TI products.

Mailing Address: Texas Instruments, Post Office Box 655303, Dallas, Texas 75265
Copyright © 2019, Texas Instruments Incorporated