

## Non-isolated Buck Offline LED Driver

### Features

- Critical Conduction Mode Operation
- Internal 500V Power MOSFET
- No Auxiliary Winding
- Ultra Low Operating Current
- $\pm 3\%$  LED Output Current Accuracy
- Efficiency up to 93%
- LED Open Protection
- LED Short Protection
- Current Sensing Resistor Short Protection
- Thermal Regulation Function
- Available in SOP-8 Package and DIP-7 Package

### Applications

- LED Candle Light
- LED Bulb, Spot Light
- T8/T10 LED String
- Other LED Lighting

### Description

The WS3441 is a high precision buck constant current LED driver. The device operates in critical conduction mode and is suitable for 85Vac~265Vac universal input offline LED lighting.

The WS3441 integrates a 500V power MOSFET. The operating current of the IC is very low. So it doesn't need the auxiliary winding for supplying the chip. It can achieve excellent constant current performance with very few external components, so the system cost and size are minimized.

The WS3441 utilizes patent pending current control method. It can achieve precise output current and excellent line regulation. The driver operates in critical conduction mode, the output current does not change with the inductance and LED output voltage.

The WS3441 offers rich protection functions to improve the system reliability, including LED open circuit protection, LED short circuit protection, VCC under voltage protection, CS resistor short circuit protection and thermal regulation function.

The WS3441 is available in SOP-8 Package and DIP-7 Package.

### Typical Application(SOP-8 Package)

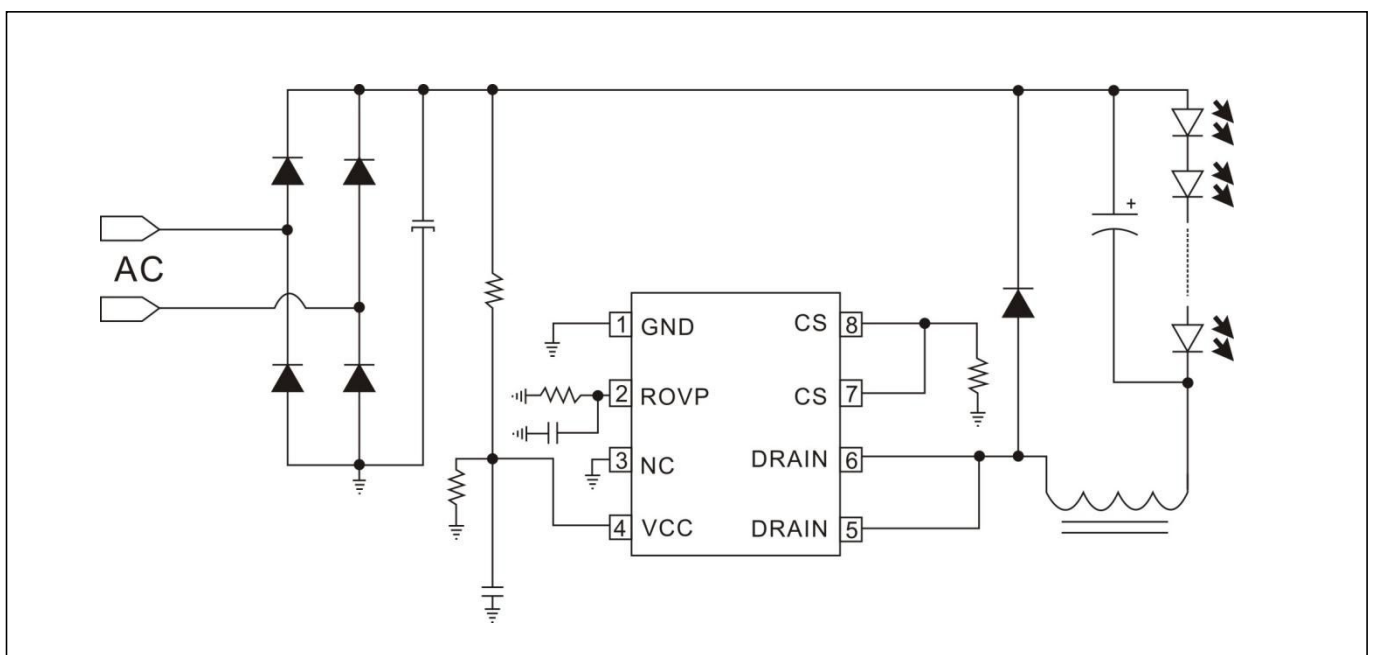

Attention: A 22pF capacitor can be parallel with Rovp and a resistor can be parallel with the Vcc capacitor.

**Typical Application(DIP-7 Package)**

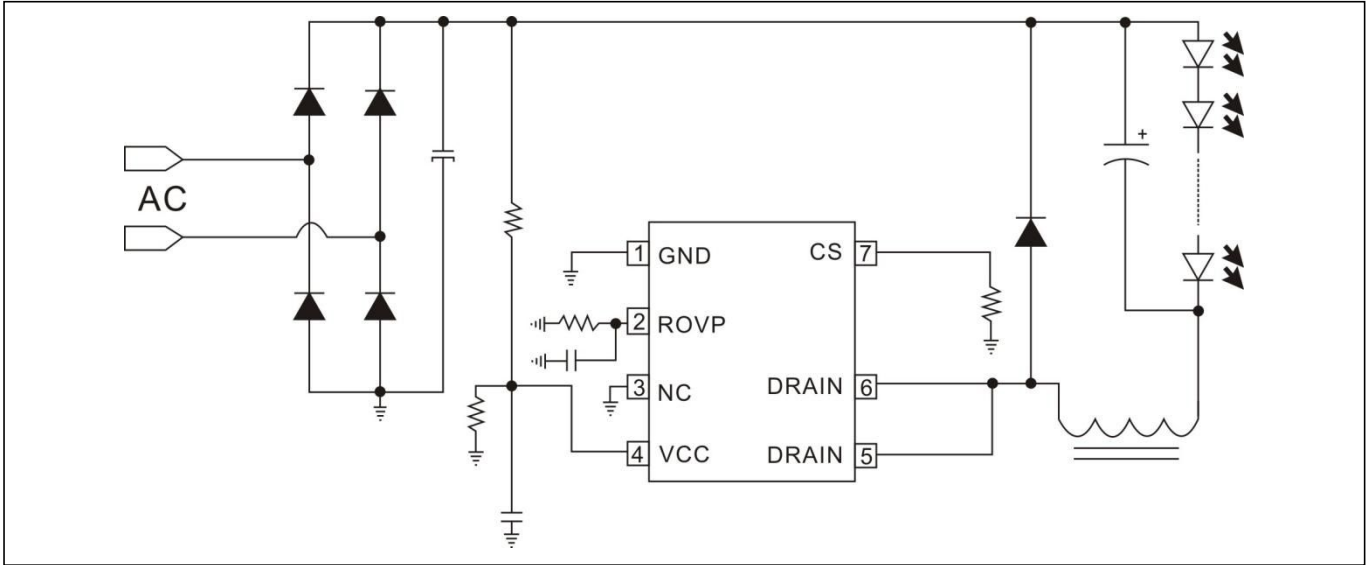

Attention: A 22pF capacitor can be parallel with Rovp and a resistor can be parallel with the Vcc capacitor.

**Pin Configuration and Marking Information**

The WS3441 is available in SOP-8 Package and DIP-7 Package,the top marking is shown as below:

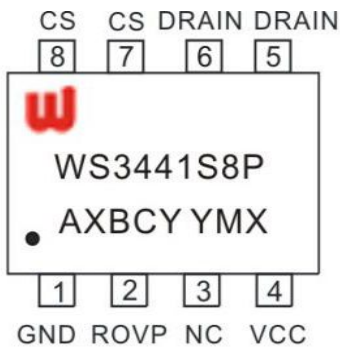

WS3441S8P  
 A: Product Code  
 X: Internal Code  
 BCY: Internal Code For QC  
 YMX: D/C

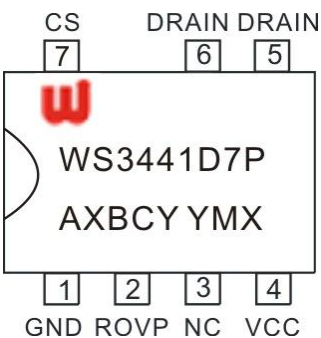

WS3441D7P  
 A: Product Code  
 X: Internal Code  
 BCY: Internal Code For QC  
 YMX: D/C

**Pin Definition**

Name	Pin No.	Description
GND	1	Ground
ROVP	2	Over Voltage Protection Setting Pin. Connect a resistor to GND
NC	3	No Connection. Should be connected to GND(Pin1)
VCC	4	Power Supply Pin
DRAIN	5/6	Internal HV Power MOSFET Drain.
CS	7/8	Current Sense Pin. Connect a sense resistor between this pin and GND pin.

**Internal Block Diagram**

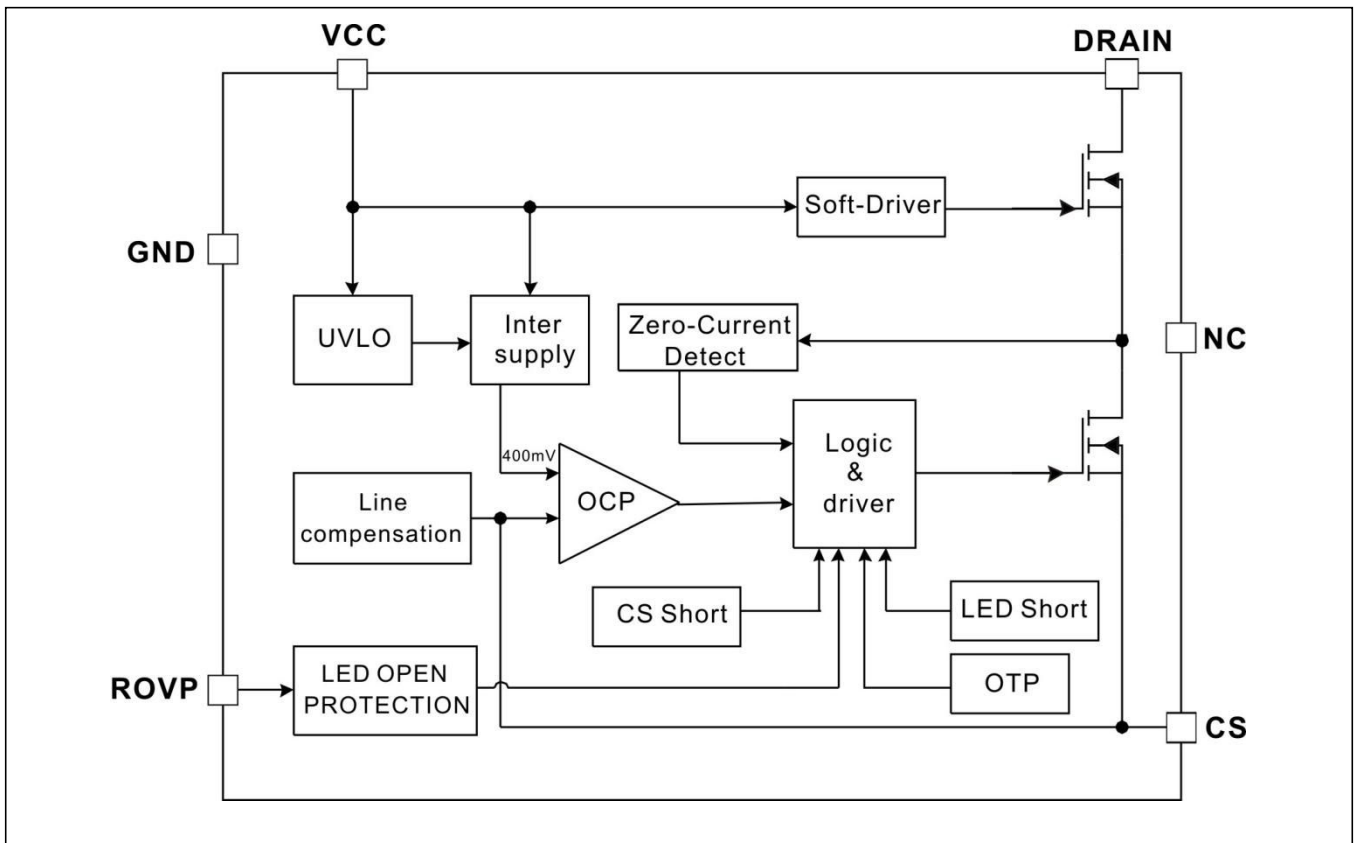

**Ordering Information**

Package	Marking	Part Number
8-Pin SOP-8, Pb-free	WS3441S8P	WS3441S8P
7-Pin DIP-7, Pb-free	WS3441D7P	WS3441D7P

**Recommended Operation Conditions**

Part Number	Package	Input voltage	Maximum output power
WS3441S8P	SOP8	175VAC-264VAC	80V/220mA 150V/150mA
		90VAC-264VAC	80V/150mA
WS3441D7P	DIP7	175VAC-264VAC	80V/280mA 120V/220mA
		90VAC-264VAC	80V/220mA 60V/300mA

**Absolute Maximum Ratings**

symbol	paramete	Range	unit
$V_{DS}$	Internal HV MOSFET drain voltage	-0.3~500	V
$I_{CC\_MAX}$	VCC pin maximum sink current	2.5	mA
$V_{ROVP}$	Over-voltage setting pin voltage	-0.3~7	V
$V_{SOURCE}$	Internal HV MOSFET source voltage	-0.3~8	V
$V_{CS}$	Current sense pin input voltage	-0.3~7	V
$P_{DMAX}$	Power dissipation SOP8	0.6	W
$P_{DMAX}$	Power dissipation DIP7	0.9	W
$T_J$	Operating junction temperature	165	°C
$T_{STG}$	Storage temperature range	-55~165	°C

**Note :** Stresses beyond those listed under “absolute maximum ratings” may cause permanent damage to the device.

**Electrical Characteristics** (Unless otherwise specified, VCC=7V and TA =25 °C)

Symbol	Parameter	Conditions	Min	Typ	Max	Units
<b>Supply Voltage Section</b>						
V <sub>cc_clamp</sub>	VCC Clamp Voltage	I <sub>vcc</sub> =1mA		7.3		V
I <sub>cc_clamp</sub>	VCC Clamp current				2.5	mA
V <sub>CC_ST</sub>	VCC Turn On Threshold	VCC Rising		6.9		V
V <sub>uvlo_HYS</sub>	VCC Turn off Hysteresis	VCC Falling		1.5		V
I <sub>st</sub>	VCC Startup Current	VCC<VCC_ST-0.5V		230	270	uA
I <sub>op</sub>	VCC Operating Current			200		uA
<b>Current Sense Section</b>						
V <sub>cs_th</sub>	Threshold Voltage for Peak Current Limit		390	400	410	mV
T <sub>LEB</sub>	Leading Edge Blanking Time for Current Sense			350		ns
T <sub>DELAY</sub>	Switch Off Delay Time			300		ns
<b>Internal Time Control Section</b>						
T <sub>OFF_MIN</sub>	Minimum OFF Time			3		us
T <sub>OFF_MAX</sub>	Maximum OFF Time			340		us
T <sub>ON_MAX</sub>	Maximum On Time			53		us
<b>MOSFET Section</b>						
R <sub>DS(on)</sub>	Static Drain-source On-resistance	V <sub>cc</sub> =7V/I <sub>d</sub> =0.5A		12.8	16	ohm
V <sub>DS_BD</sub>	Drain-Source Breakdown Voltage	V <sub>gs</sub> =0V/I <sub>d</sub> =250uA	500			V
I <sub>dss</sub>	Power MOSFET Drain Leakage Current	V <sub>gs</sub> =0V/V <sub>ds</sub> =500V			10	uA
<b>ROVP section</b>						
V <sub>ROVP</sub>	ROVP Pin Voltage			0.5		V
<b>Thermal Regulation Section</b>						
T <sub>SD</sub>	Thermal Shutdown Temperature			160		°C
T <sub>SD_HYS</sub>	Thermal Shutdown Hysteresis			20		°C
T <sub>comp</sub>	Thermal Regulation Temperature			150		°C

### Application Information

The WS3441 is a high performance non-isolated Buck converter specially designed for LED lighting. The device integrates a 500V power MOSFET. With very few external components, the converter achieves excellent constant current control. And it does not need auxiliary winding for powering the IC or voltage sensing, hence the system size and cost is greatly reduced.

### Start Up

After system powered up, the VCC pin capacitor is charged up by the start up resistor. When the VCC pin voltage reaches the turn on threshold, the internal circuits start operating. The WS3441 integrates a 17V zener diode to clamp the VCC voltage. Due to the ultra-low operating current, the auxiliary winding is not needed to supply the IC.

The maximum value of the start up current is 270uA. For the application of 176VAC — 264VAC, the start up resistor can be calculated by the equation:

$$R_{st} < \frac{V_{in\_min} \times 1.414}{I_{st\_max}} \approx \frac{176V \times 1.414}{270\mu A} = 920k\Omega$$

### Constant Current Control

Cycle by Cycle current sense is adopted in WS3441, the CS pin is connected to the current sense comparator, and the voltage on CS pin is compared with the internal 400mV reference voltage. The MOSFET will be switched off when the voltage on CS pin reaches the threshold. The CS comparator includes a 350ns leading edge blanking time.

The peak inductor current is given by:

$$I_{PK} = \frac{400}{R_{CS}} \text{ (mA)}$$

Where, RCS is the current sense resistor value.

The current in LED can be calculated by the equation:

$$I_{LED} = \frac{I_{PK}}{2}$$

Where, IPK is the peak current of the inductor.

### Inductor Selection

The WS3441 works under inductor current critical conduction mode. When the power MOFET is switched on, the current in the inductor rises up from zero, the on time of the MOSFET can be calculated by the equation:

$$t_{on} = \frac{L \times I_{PK}}{V_{IN} - V_{LED}}$$

Where,

L is the inductance value

VIN is the DC bus voltage after the rectifier bridge

VLED is the voltage on the LED

After the power MOSFET is switched off, the current in the inductor decreases. When the inductor current reaches zero, the power MOSFET is turned on again by IC internal logic. The off time of the MOSFET is given by:

$$t_{off} = \frac{L \times I_{PK}}{V_{LED}}$$

The inductance can be calculated by the equation:

$$L = \frac{V_{LED} \times (V_{IN} - V_{LED})}{f \times I_{PK} \times V_{IN}}$$

The f is the system switching frequency, which is proportional to the input voltage. So the minimum switching frequency is set at lowest input voltage, and the maximum switching frequency is set at highest input voltage.

The minimum and maximum off time of WS3441 is set at 3us and 340us, respectively. Referring to the equation of Toff calculation, if the inductance is too small, the Toff may be smaller than the minimum off time, system will operate in discontinuous conduction mode and the output current will be smaller than the designed value. If the inductance is too large, the Toff may be larger than the maximum off time, the system will operate in continuous conduction mode and the output current will be higher than the designed value. So it is important to choose a proper inductance.

### Over Voltage Protection

The over voltage protection can be programmed by the ROVP pin resistor. The ROVP pin voltage is 0.5V.

When the LED is open circuit, the output voltage increases gradually, and the demagnetization time gets shorter. The demagnetization time at OVP---- Tovp can be calculated by the open circuit protection voltage:

$$Tovp \approx \frac{L \times Vcs}{Rcs \times Vovp}$$

Where,

Vcs is the CS pin turn off threshold (400mV)

Vovp is the open circuit protection voltage

And then the Rovp resistor value can be calculated by the equation:

$$Rovp \approx 3.3 * T_{ovp} * 10^6 \quad (\text{kohm})$$

### Protection Function

The WS3441 offers rich protection functions to improve the system reliability, including LED open/short protection, CS resistor short protection, VCC under voltage protection, thermal regulation. When the LED is open circuit, the system will trigger the over voltage protection and stop switching.

When the LED short circuit is detected, the system works at low frequency (5kHz), and the CS pin turn off threshold is reduced to 200mV. So the system power consumption is very low. At some catastrophic fault condition, such as CS resistor shorted or inductor saturated, the internal fast fault detection circuit will be triggered, the system stops switching immediately.

After the system enters into fault condition, the VCC voltage will decrease until it reaches the UVLO threshold, then the system will re-start again. If the fault condition is removed, the system will recover to normal operation.

### Thermal Regulation

The WS3441 integrates thermal regulation function. When the system is over temperature, the output current is gradually reduced; the output power and thermal dissipation are also reduced. The system temperature is regulated and the system reliability is improved. The thermal regulation temperature is set to 150°C internally.

### PCB Layouts

The following rules should be followed in WS3441 PCB layout:

#### Vcc Capacitor

The bypass capacitor on VCC pin should be as close as possible to the VCC Pin and GND pin.

#### ROVP Pin

The ROVP resistor should be as close as possible to the ROVP Pin.

#### Ground Path

The power ground path for current sense should be short, and the power ground path should be separated from small signal ground path before connecting to the negative node of the bulk capacitor.

#### The Area of Power Loop

The area of main current loop should be as small as possible to reduce EMI radiation, such as the inductor, the power MOSFET, the output diode and the bus capacitor loop.

#### NC pin

The NC pin should be connected to GND (pin1).

#### Drain Pin

To increase the copper area of DRAIN pin for better thermal dissipation. However too large copper area may compromise EMI performance.

#### The material of PCB

Avoid choosing the material that is easy to absorb the moisture, just like paper copper-clad laminates.

**Package Information**

**SOP8 Package Outline Dimensions**

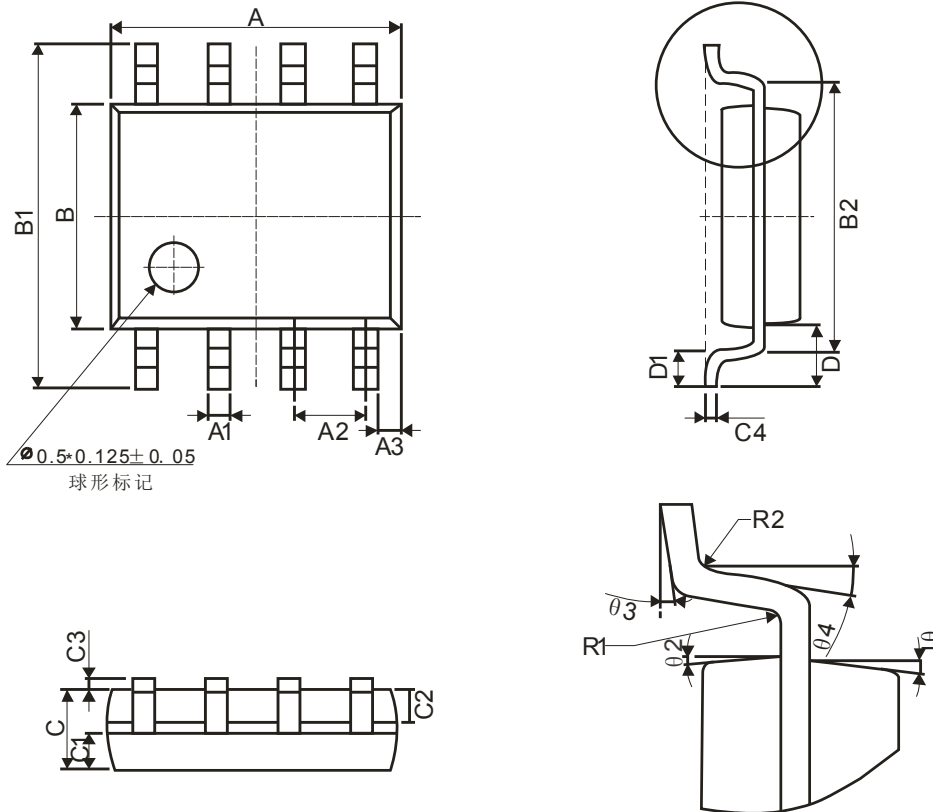

Winsemi				
Symbol	Dimensions in Millimeters		Dimensions in Inches	
	Min	Max	Min	Max
A	4.70	5.10	0.185	0.201
B	3.70	4.10	0.146	0.161
C	1.30	1.50	0.051	0.059
A1	0.35	0.48	0.014	0.019
A2	1.27TYP		0.05TYP	
A3	0.345TYP		0.014TYP	
B1	5.80	6.20	0.228	0.244
B2	5.00TYP		0.197TYP	
C1	0.55	0.70	0.022	0.028
C2	0.55	0.70	0.022	0.028
C3	0.05	0.225	0.002	0.009
C4	0.203TYP		0.008TYP	
D	1.05TYP		0.041TYP	
D1	0.40	0.80	0.016	0.031



DIP7 Package Outline Dimensions

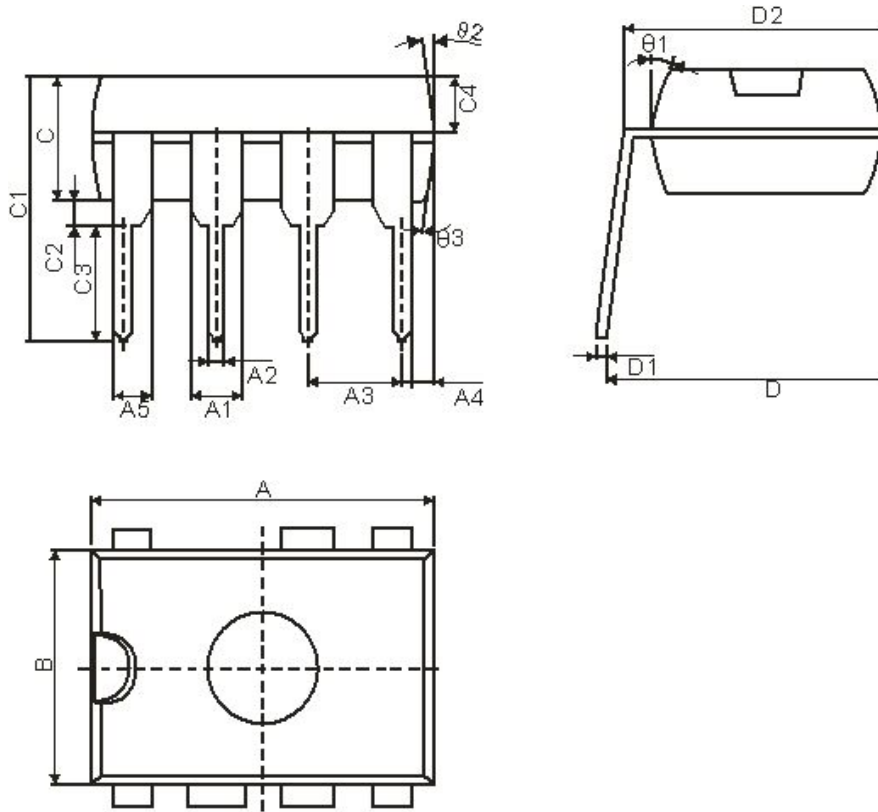

Winsemi				
Symbol	Dimensions in Millimeters		Dimensions in Inches	
	Min	Max	Min	Max
A	9.00	9.50	0.354	0.374
B	6.10	6.60	0.240	0.260
C	3.0	3.4	0.118	0.134
A1	1.474	1.574	0.058	0.062
A2	0.41	0.53	0.016	0.021
A3	2.44	2.64	0.096	0.104
A4	0.51TYP		0.02TYP	
A5	0.99TYP		0.04TYP	
C1	6.6	7.30	0.260	0.287
C2	0.50TYP		0.02TYP	
C3	3.00	3.40	0.118	0.134
C4	1.47	1.65	0.058	0.065
D	7.62	9.3	0.300	0.366
D1	0.24	0.32	0.009	0.013
D2	7.62TYP		0.3TYP	

**NOTE:**

- 1.We strongly recommend customers check carefully on the trademark when buying our product, if there is any question, please don't be hesitate to contact us.
- 2.Please do not exceed the absolute maximum ratings of the device when circuit designing.
- 3.Winsemi Microelectronics Co., Ltd reserved the right to make changes in this specification sheet and is subject to change without prior notice.

**CONTACT:**

Winsemi Microelectronics Co., Ltd.

ADD:Futian District, ShenZhen Tian An Cyber Tech Plaza two East Wing 1002

Post Code : 518040

Tel : +86-755-8250 6288

FAX : +86-755-8250 6299

Web Site : [www.winsemi.com](http://www.winsemi.com)