

参考图
 签字: 董利利
 日期: 2018.9.18

REVISION RECORD				
REV	ECN	DESCRIPTION	DRFT	DATE

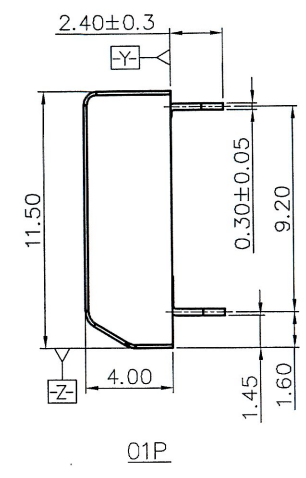
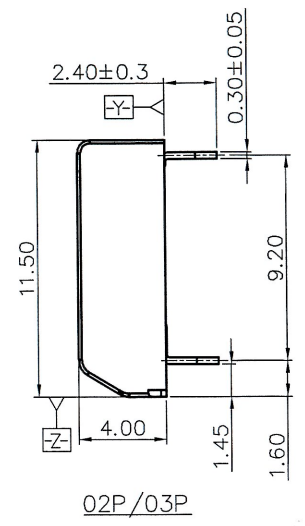
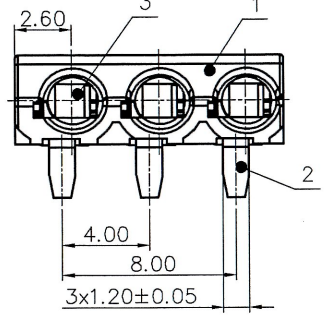
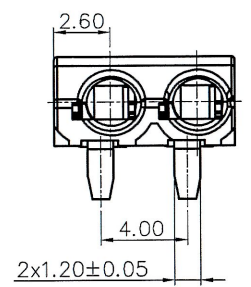
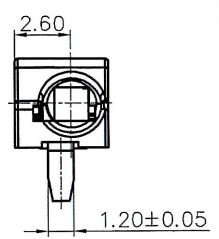
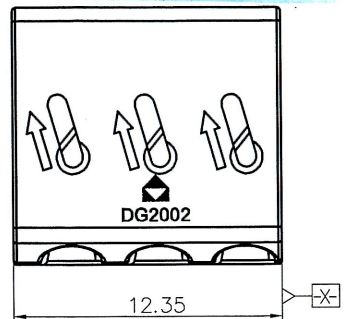
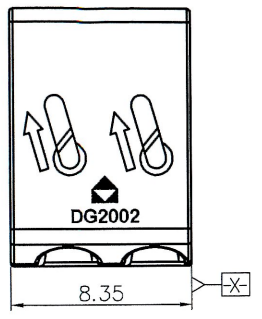
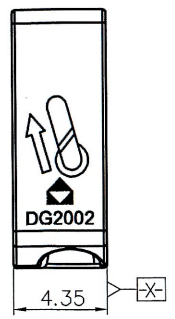

NOTES1:
 UL Standard
 1. Rated voltage/current : 600V / 9A(01P)
 300V / 9A(02P/03P)
 2. Wire range : 24~18AWG

IEC Standard

1. Pollution degree	3	2	2
Overvoltage category	III	III	II
Rate impulse voltage(KV)	4.0KV	4.0KV	4.0KV
Rate voltage(V)	32V	160V	160V
Rate current(A)	9A		

2. Wire range : 0.2~0.75mm²

DG2002 - 4.0 - XXP - 1Y - 300A (H)
 (Series No.) (Pitch) (Poles) (Single Pitch) (Color): 1.(Grey) 2.(Blue) 3.(Black) 7.(Transparent) 4.(Green) 8.(Yellow) 5.(Orange) 9.(White)

NOTES2:
 1. Dimension shall be interpreted per ASME Y14.5-2009
 2. Pitch : 4.00mm, Poles : N=01~03P
 3. Stripping length : 8~9mm
 4. Operating temperature: -40°C~+130°C
 5. Undimensioned tolerances:

Pitch range in mm	Nominal dimension range in mm						±	∠
TO	Over 6 TO 10	Over 10 TO 24	Over 30 TO 30	Over 30 TO 60	Over 60 TO 100	Over 100 TO 150	0.1/10	∠
±0.15	±0.20	±0.30	±0.30	±0.50	±0.70	±1.00	±1.30	±2'

6. RoHS Compliance

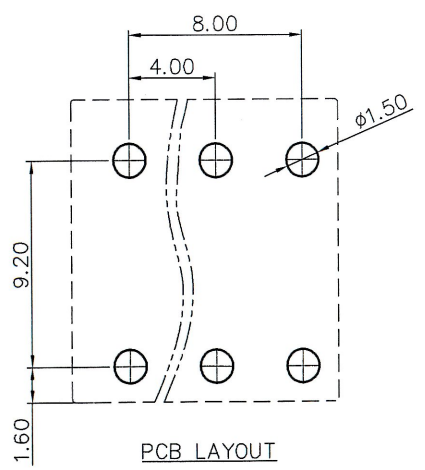

ITEM	NAME OF PART	MATERIAL	NOTES
3	Spring	Stainless steel	/
2	Pin header	Copper alloy	Sn Plated
1	Housing	LCP	UL94V-0

PART NO.: /		宁波高松电子有限公司 DEGSON [®] NINGBO DEGSON ELECTRICAL CO., LTD			
APPD: Robin 2018.9.18		NAME: DG2002-4.0-XXP-1Y-300A(H)			
CHKD: 7		DRFT: Xin 2018.09.18		TITLE: CUSTOMER DRAWING	REV: TO-1
THIRD ANGLE PROJECTION		DRAWING NO.: DG2002-4.0-C08		SHEET: 1/1	SCALE: 1:1
		DO NOT SCALE DRAWING			