

# 1N4614 SERIES

## AXIAL LEAD ZENER DIODES

**VOLTAGE** 1.8 to 6.2 Volt **POWER** 500mWatt

**DO-35** Unit : inch(mm)

### FEATURES

- Planar Die construction
- 500mW Power Dissipation
- Ideally Suited for Automated Assembly Processes
- Lead free in compliance with EU RoHS 2011/65/EU directive

### MECHANICAL DATA

- Case: Molded Glass DO-35
- Terminals: Solderable per MIL-STD-750, Method 2026
- Approx. Weight: 0.00465 ounces, 0.131 grams
- Ordering information: Suffix : " -35 " to order DO-35 Package
- Packing information
  - B - 2K per Bulk box
  - T/R - 10K per 15" plastic Reel
  - T/B - 5K per horiz. tape & Ammo box

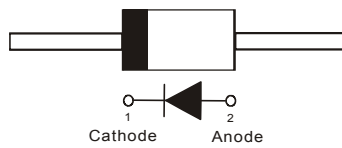
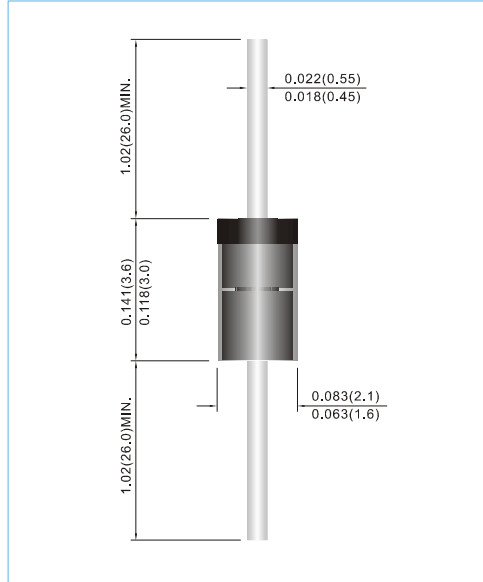

## MAXIMUM RATINGS AND ELECTRICAL CHARACTERISTICS (T<sub>A</sub>=25°C unless otherwise noted)

Rating	Symbol	Value	Units
Power Dissipation at T <sub>A</sub> = 25 °C	P <sub>TOT</sub>	500	mW
Maximum Forward Voltage at I <sub>F</sub> =100mA	V <sub>F</sub>	1	V
Maximum Thermal Resistance Junction to Ambient Air (Notes 1)	R <sub>JA</sub>	300	°C / W
Operating Junction Temperature Range	T <sub>J</sub>	-55 to +175	°C
Storage Temperature Range	T <sub>STG</sub>	-55 to +175	°C

### NOTES :

1. Valid provided that leads at a distance of 10mm from case are kept at ambient temperature.

# 1N4614 SERIES

Part Number	Nominal Zener Voltage			Max. Zener Impedance		Max. Reverse Leakage Current		Marking Code
	V <sub>Z</sub> @ I <sub>ZT</sub>			Z <sub>ZT</sub> @ I <sub>ZT</sub>		I <sub>R</sub> @ V <sub>R</sub>		
	Nom.V	Min.V	Max.V	Ω	mA	μA	V	
1N4614	1.8	1.710	1.890	1200	0.25	7.5	1.0	1N4614
1N4615	2.0	1.900	2.100	1250	0.25	5.0	1.0	1N4615
1N4616	2.2	2.090	2.310	1300	0.25	4.0	1.0	1N4616
1N4617	2.4	2.280	2.520	1400	0.25	2.0	1.0	1N4617
1N4618	2.7	2.565	2.835	1500	0.25	1.0	1.0	1N4618
1N4619	3.0	2.850	3.150	1600	0.25	0.8	1.0	1N4619
1N4620	3.3	3.135	3.465	1650	0.25	7.5	1.5	1N4620
1N4621	3.6	3.420	3.780	1700	0.25	7.5	2.0	1N4621
1N4622	3.9	3.705	4.095	1650	0.25	5.0	2.0	1N4622
1N4623	4.3	4.085	4.515	1600	0.25	4.0	2.0	1N4623
1N4624	4.7	4.465	4.935	1550	0.25	10	3.0	1N4624
1N4625	5.1	4.845	5.355	1500	0.25	10	3.0	1N4625
1N4626	5.6	5.320	5.880	1400	0.25	10	4.0	1N4626
1N4627	6.2	5.890	6.510	1200	0.25	10	5.0	1N4627

# 1N4614 SERIES

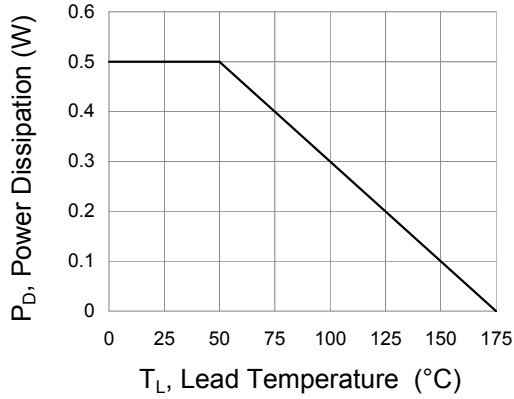

**Fig.1 Power Derating Curve**

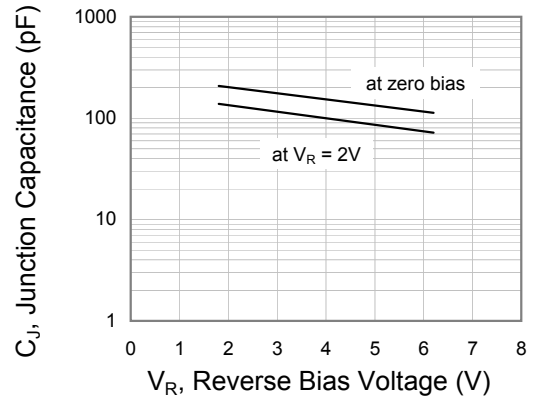

**Fig.2 Typical Junction Capacitance**

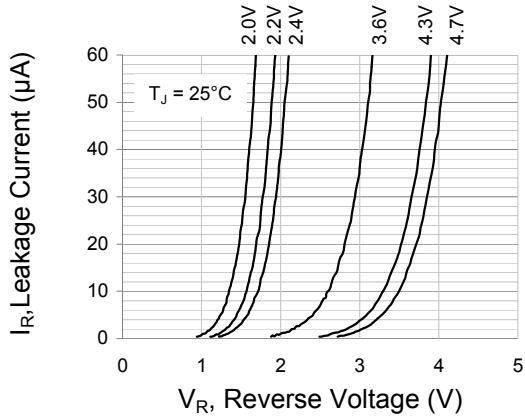

**Fig.3 Typical Leakage Characteristics**

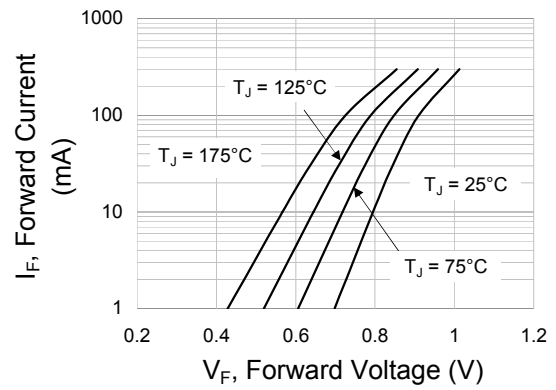

**Fig.4 Typical Forward Characteristics**

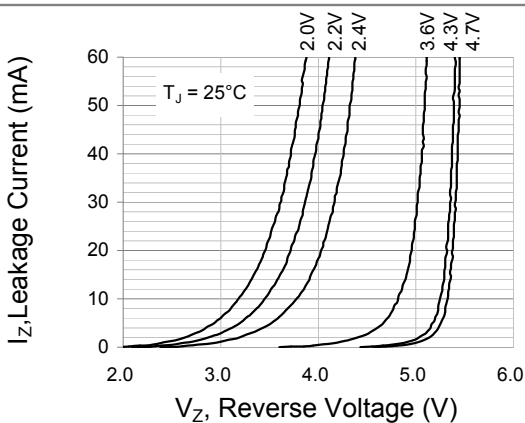

**Fig.5 Typical Zener Characteristics**

# 1N4614 SERIES

**Part No\_packing code\_Version**

- 1N4614\_AX\_10001
- 1N4614\_AY\_10001
- 1N4614\_R2\_10001
- 1N4614\_B0\_10001

For example :

**RB500V-40\_R2\_00001**

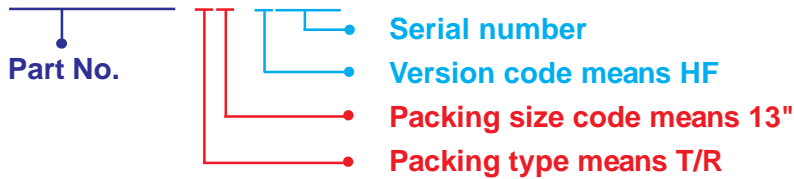

Packing Code <b>XX</b>				Version Code <b>XXXXX</b>		
Packing type	1 <sup>st</sup> Code	Packing size code	2 <sup>nd</sup> Code	HF or RoHS	1 <sup>st</sup> Code	2 <sup>nd</sup> ~5 <sup>th</sup> Code
Tape and Ammunition Box (T/B)	A	N/A	0	HF	0	serial number
Tape and Reel (T/R)	R	7"	1	RoHS	1	serial number
Bulk Packing (B/P)	B	13"	2			
Tube Packing (T/P)	T	26mm	X			
Tape and Reel (Right Oriented) (TRR)	S	52mm	Y			
Tape and Reel (Left Oriented) (TRL)	L	PANASERT T/B CATHODE UP (PBCU)	U			
FORMING	F	PANASERT T/B CATHODE DOWN (PBCD)	D			

## 1N4614 SERIES

---

### Disclaimer

- Reproducing and modifying information of the document is prohibited without permission from Panjit International Inc..
- Panjit International Inc. reserves the rights to make changes of the content herein the document anytime without notification. Please refer to our website for the latest document.
- Panjit International Inc. disclaims any and all liability arising out of the application or use of any product including damages incidentally and consequentially occurred.
- Panjit International Inc. does not assume any and all implied warranties, including warranties of fitness for particular purpose, non-infringement and merchantability.
- Applications shown on the herein document are examples of standard use and operation. Customers are responsible in comprehending the suitable use in particular applications. Panjit International Inc. makes no representation or warranty that such applications will be suitable for the specified use without further testing or modification.
- The products shown herein are not designed and authorized for equipments requiring high level of reliability or relating to human life and for any applications concerning life-saving or life-sustaining, such as medical instruments, transportation equipment, aerospace machinery et cetera. Customers using or selling these products for use in such applications do so at their own risk and agree to fully indemnify Panjit International Inc. for any damages resulting from such improper use or sale.
- Since Panjit uses lot number as the tracking base, please provide the lot number for tracking when complaining.