

REVISION RECORD

REV	ECN	DESCRIPTION	DRFT	DATE

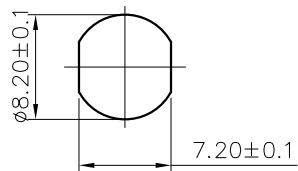
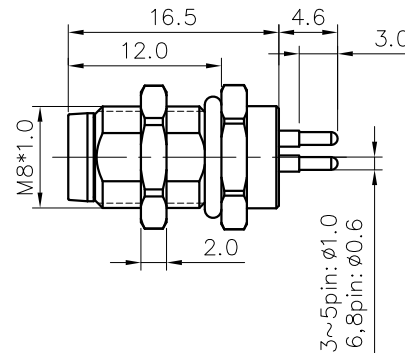
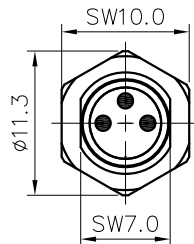

Panel cut

SP-M8X-XXP-MM-SF7003-00A(H)

Coding: A,B

Pin number: 03,04,  
05,06,08

NOTES:

- Rated voltage/current : 3pin: 60V / 3A  
4pin: 60V / 3A  
5pin: 30V / 3A  
6pin: 30V / 1.5A  
8pin: 30V / 1.5A

- Withstanding voltage : AC800V/1Min
- Levels of protection: IP67

- Wire connection mode: soldering(PCB)
- Operating temperature: -40°C~+85°C
- For Panel Thickness Range: 2.0~4.5mm
- RoHS Compliance

	3pin A Coding	4pin A Coding	5pin B Coding	6pin A Coding	8pin A Coding
C					
B	Pin Assignment Front View	Pin Assignment Front View	Pin Assignment Front View	Pin Assignment Front View	Pin Assignment Front View
A					
	PCB layout	PCB layout	PCB layout	PCB layout	PCB layout

DETACHED LISTS	PART NO.: SPM8XXXPMMSF700300AH	宁波高松电子有限公司 NINGBO DEGSON ELECTRICAL CO., LTD		
	APPD:	NAME: SP-M8X-XXP-MM-SF7003-00A(H)		
	CHKD:	TITLE: CUSTOMER DRAWING		
	DRFT: LZ 2018.09.07	REV	D0-1	
		DRAWING NO.: XXXXXXXX-XX-CXX	SHEET	1/1
		MM (INCH)	DO NOT SCALE DRAWING	SCALE
			SCALE	1:1