

Specification

Model		LFS-02	
Electrical Function		1 pole NO	
Electrical Rating		250mA,250Vac	
Ambient Temperature		-10~+90°C	
Electrical Connection		Weld or Wire Leads	
Pressure Setting/Tolerance		85 mbar/±10% mbar	
Connection		2 Parallel Interfaces	
Media		Non-hazardous gas only	
Mounting		Solder on PC boards	
List of Parts	Name	Materials	Remarks
	Upper Cover	PA66 (Red)	
	Connection Base	PBT (White)	
	Adjusting Screw	PA66 (Red)	
	Electrical Contact	Silver Plated Brass	
	Diaphragm	Silastic	
	Pin	Silver Plated Brass	
<p>--Wire and terminal as required.</p> <p>--Soldering: wave soldering temperature: 260±5°C, soldering time: <3s.</p>			

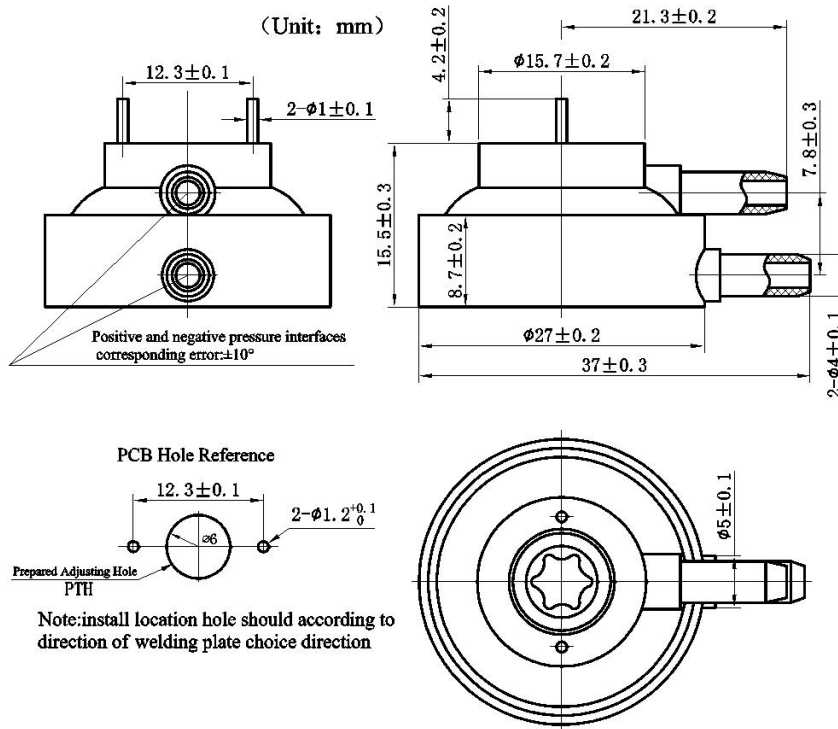

Projection Method: The First Angle Method		Linear Dimension Tolerance 0.5~3mm ±0.1mm 3~6mm ±0.1mm 6~30mm ±0.2mm 30~120mm ±0.3mm 120~400mm ±0.5mm		<h2 style="margin: 0;">Specification</h2>		ZHEJIANG LEFOO CONTROLS CO., LTD.	
				S A B	2:1	LFS-02 Pressure Switch	
Design	Standard			Page 1 of 1		1.020.XXXX	
Checked	Authorize			Version NO.:A1.0 Save :			
Technics	Date						