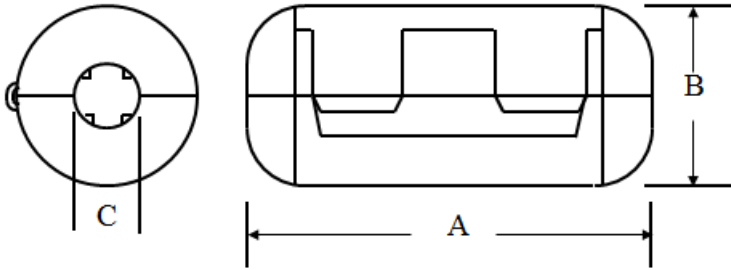

# SPECIFICATION FOR APPROVAL

CUSTOMER:				DATE:	
PART NO: LF – 35B (B15)				DWG.NO: SY2116429B15	
CUSTOMER PART NO:				CUST.DWG.NO:	
(1) DIMENSION(UNIT:mm)  				A	25.0 ± 0.5 m/m
				B	14.5 ± 0.5 m/m
				C	3.8 ± 0.3 m/m
				D	m/m
				E	m/m
				F	m/m
				G	m/m
				H	m/m
				I	m/m
				J	m/m
				(2)ELECTRICAL REQUIREMENTS	
Z	MIN 60 OHM	TEST FREQ	25 MHz	B:BLACK W:WHITE G:GRAY	
Z	MIN 120 OHM	TEST FREQ	100 MHz		
Z	MIN OHM	TEST FREQ	MHz		
Z	MIN OHM	TEST FREQ	MHz		
(4)TEST INSTRUMENTS					
HP-4991A					
MATERIAL (ui)	1500 ± 25%			APPROVED BY 吳載敏	
CORE	UH-8.4×15.5×3.8			CHECKED BY 張明德	
WIRE	φ 0.6 × 100 mm			DRAWN BY Vicky	
WINDING	1 Ts				

**CORE MASTER ENTERPRISE CO., LTD.**

TEL:886-2-8919-1288    FAX:886-2-8919-1298    WEB:www.coremaster.com.tw

# TEST DATA

CUSTOMER :				DATE :					
PART NO: LF - 35B (B15)				DWG.NO: SY2116429B15					
CUSTOMER PART NO :				CUST.DWG.NO :					
IMPEDANCE				DIMENSION (UNIT : mm)					
FREQ	25 MHz	100 MHz		A	B	C			
SPEC	MIN 60 OHM	MIN 120 OHM		25.0 ± 0.5	14.5 ± 0.5	3.8 ± 0.3			
1	80.0	160.2		25.12	14.62	3.83			
2	84.6	161.1		25.08	14.57	3.91			
3	84.8	158.7		25.11	14.53	3.85			
4	84.6	157.9		25.06	14.59	3.87			
5	74.3	160.8		25.05	14.48	3.79			
6	80.0	160.2		25.12	14.62	3.83			
7	84.6	161.1		25.08	14.57	3.91			
8	84.8	158.7		25.11	14.53	3.85			
9	84.6	157.9		25.06	14.59	3.87			
10	74.3	160.8		25.05	14.48	3.79			
X	81.7	159.7		25.08	14.56	3.85			
R	10.5	3.2		0.07	0.14	0.12			
REMARK: 產品不能有明顯缺陷、污損；產品缺口長、寬在 0.6mm 以下， 深在 0.6mm 以下。							APPROVED BY		
							吳載敏		
							CHECKED BY		
			張明德						
			DRAWN BY						
			Vicky						

**CORE MASTER ENTERPRISE CO., LTD.**

TEL:886-2-8919-1288    FAX:886-2-8919-1298    WEB:www.coremaster.com.tw

# LF-35B (B15)

