

REVISION RECORD			
REV	ECN	DESCRIPTION	DRFT DATE

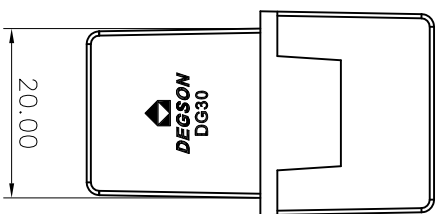
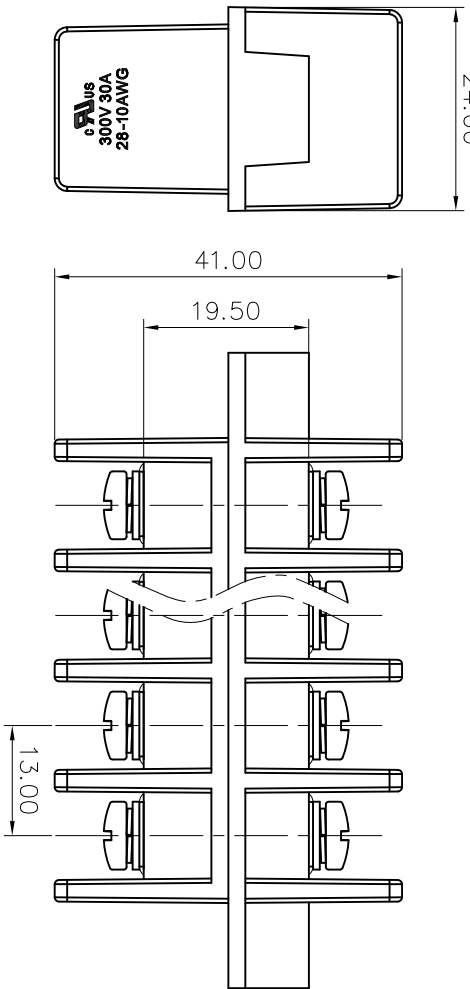
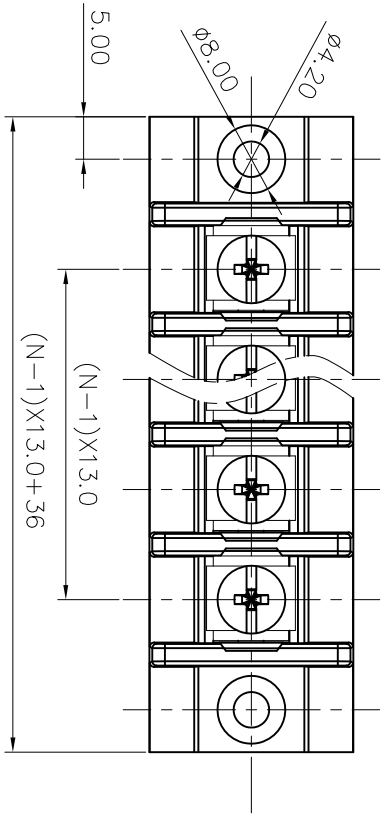

NOTES1:
 UL Standard
 1. Rated voltage/current : 300V / 30A
 2. Torque value : M4 , 10.53Lb.in
 3. Wire range : 28~10AWG

NOTES2:
 1. Dimension shall be interpreted per ASME Y14.5-2009
 2. Pitch : 13.0mm, Poles : N=02~10P
 3. Withstanding voltage : AC1600V/1Min
 4. Operating temperature: -40C~+105C
 5. Undimensioned tolerances:

Pitch range in mm	Nominal dimension range		mm	mm
	Over	Under		
6	10	0	0.1/10	±0.15
10	10	0	0.1/10	±0.20
15	10	0	0.1/10	±0.30
24	10	0	0.1/10	±0.50
30	10	0	0.1/10	±0.70
60	100	150	±1.00	±1.30
150	150	150	±1.30	±2

6. RoHS Compliance

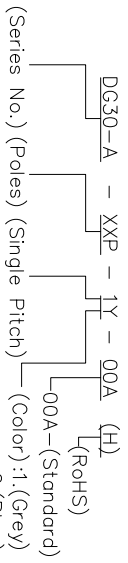

- (Series No.) (Poles) (Single Pitch) (Color) : 1. (Grey)
 2. (Blue)
 3. (Black)
 4. (Green)
 5. (Orange)
 6. (Red)
 7. (Transparent)
 8. (Yellow)
 9. (White)

DETACHED LISTS	
PART NO.:	/
APPD:	/
CHKD:	/
DRFT:	/
THIRD ANGLE PROJECTION	
NAME:	DEGSON NINGBO DEGSON ELECTRICAL CO., LTD 宁波高松电子有限公司
TITLE:	CUSTOMER DRAWING
DRAWING NO.:	/
REV	DO
SHEET	1/1
SCALE	1:1