

4010

40x40x10MM

General Specifications

- ◆ Material..... Frame: Plastic (UL94V-0)
Impeller: Plastic (UL94V-0)
Lead Wire: UL1007AWG#26 or Equivalent (+) Red, (-) Black
- ◆ Expected Life..... Ball Bearing 70,000hrs (40°C)
Sleeve Bearing 30,000hrs (40°C)
- ◆ Temperature Range.... Operating temperature -10°C~70°C (Non-condensing)
Storage temperature -40°C~70°C (Non-condensing)
- ◆ Safety Standards..... UL, TUV, RoHS, CE
- ◆ DC Fan Specials..... RD, FG, IP56



Specifications

Model	#Bearing Type	Rated Voltage	Operating Voltage	Input Current	Input Power	Speed	Max Air Flow		Max Static Pressure		Noise	Weight
Part No.	B.S	VDC	VDC	Amp	Watt	RPM	CFM	m ³ /min	Inch-H ₂ O	Pa	dB-A	g
DA04010#05H	B.S	5	3.5~5.5	0.22	1.10	7000	7.50	0.21	0.15	36.87	32.0	16.0
DA04010#05M	B.S	5	3.5~5.5	0.14	0.70	6000	6.42	0.18	0.12	29.42	27.0	16.0
DA04010#05L	B.S	5	3.5~5.5	0.10	0.50	5000	5.54	0.15	0.09	21.67	24.0	16.0
DA04010#05D	B.S	5	3.5~5.5	0.08	0.40	4000	4.39	0.12	0.06	14.32	21.0	16.0
DA04010#12H	B.S	12	7.0~13.8	0.15	1.80	7000	7.50	0.21	0.15	36.87	32.0	16.0
DA04010#12M	B.S	12	7.0~13.8	0.08	0.96	6000	6.42	0.18	0.12	29.42	27.0	16.0
DA04010#12L	B.S	12	7.0~13.8	0.06	0.72	5000	5.54	0.15	0.09	21.67	24.0	16.0
DA04010#12D	B.S	12	7.0~13.8	0.04	0.48	4000	4.39	0.12	0.06	14.32	21.0	16.0
DA04010#24H	B.S	24	14.0~27.6	0.07	1.68	7000	7.50	0.21	0.15	36.87	32.0	16.0
DA04010#24M	B.S	24	14.0~27.6	0.05	1.20	6000	6.42	0.18	0.12	29.42	27.0	16.0
DA04010#24L	B.S	24	14.0~27.6	0.04	0.96	5000	5.54	0.15	0.09	21.67	24.0	16.0

Specifications are subject to change without notice. Please visit our website at <http://www.szhxht.com> for update information

Dimensions (Unit:mm)

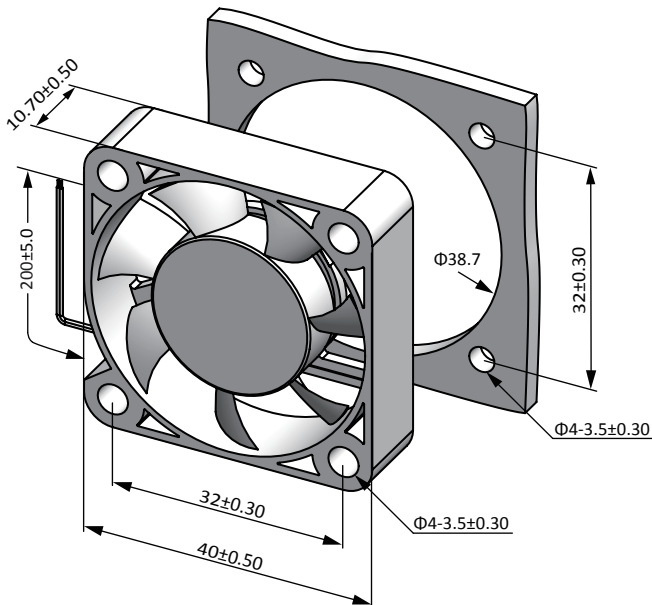

PQ Curve (At rated Voltage)

