

REVISION RECORD				
REV	ECN	DESCRIPTION	DRFT	DATE

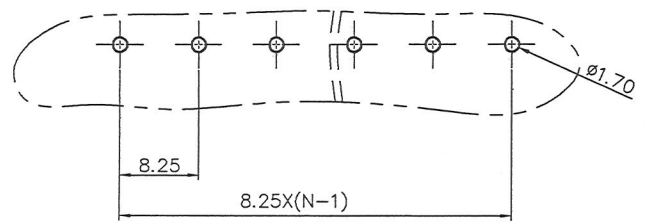
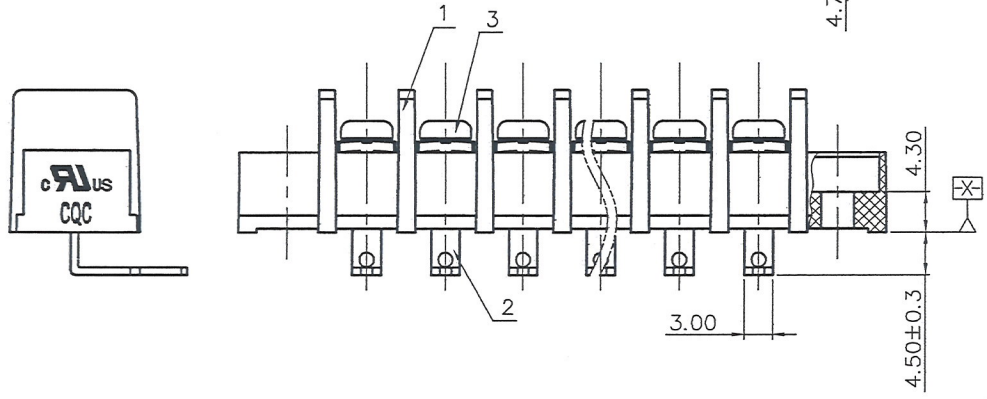
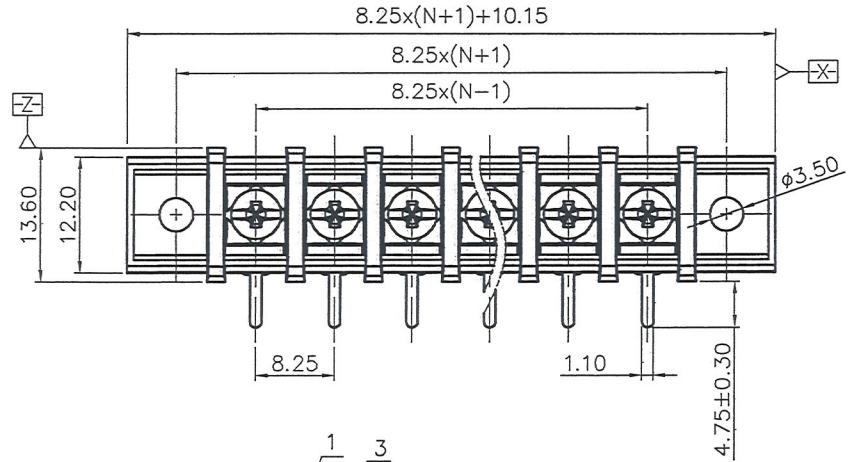

NOTES1:  
 UL Standard  
 1.Rated voltage/current : 300V / 20A  
 2.Torque value : M3 , 4.43Lb.in  
 3.Wire range : 22~12AWG

NOTES2:  
 1.Dimension shall be interpreted per ASME Y14.5-2009  
 2.Pitch : 8.25mm, Poles : N=02~26P  
 3.Withstanding voltage : AC1600V/1Min  
 4.Operating temperature: -40°C~+105°C  
 5.Undimensioned tolerances:

Pitch range in mm		Nominal dimension range in mm						0.1/10
TO	Over	Over	Over	Over	Over	Over	<	
6	10	10	24	30	60	100		
±0.15	±0.20	±0.30	±0.30	±0.50	±0.70	±1.00	±1.30	±2'

6.RoHS Compliance

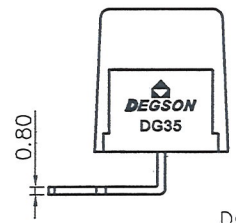

DG35R-A - XXP - 1Y - 00A (H)  
 (RoHS)  
 00A-(Standard)  
 (Series No.)(Poles)(Single Pitch) (Color):  
 1.(Grey)  
 2.(Blue)  
 3.(Black)  
 4.(Green)  
 5.(Orange)  
 6.(Red)  
 7.(Transparent)  
 8.(Yellow)  
 9.(White)

ITEM	NAME OF PART	MATERIAL	NOTES
3	SCREW	Steel	M3/Ni plated
2	Pin header	Copper alloy	Sn plated
1	HOUSING	PA66	UL94V-0

PART NO.: /		宁波高松电子有限公司 NINGBO DEGSON ELECTRICAL CO., LTD	
APPD: <i>Raymond</i>	NAME: DG35R-A-XXP-1Y-00A(H)		
CHKD: <i>Raymond</i>	DRFT: LJB 2017.09.16	TITLE: CUSTOMER DRAWING	REV: TO
THIRD ANGLE PROJECTION		DRAWING NO.: DG35R-C03	SHEET: 1/1
MM (INCH)		DO NOT SCALE DRAWING	SCALE: 1:1