

17251 172x172x51MM

General Specifications

- ◆ Material..... Frame: Plastic (UL94V-0)  
Impeller: Plastic (UL94V-0)  
Lead Wire: UL1007AWG#22 or Equivalent (+) Red, (-) Black
- ◆ Expected Life..... Ball Bearing 70,000hrs (40°C)
- ◆ Temperature Range.... Operating temperature -10°C~70°C (Non-condensing)  
Storage temperature -40°C~70°C (Non-condensing)
- ◆ Safety Standards..... UI, TUV, RoHS, CE
- ◆ DC Fan Specials..... RD, FG, PWM, Temperature control, IP56



Specifications

Model	#Bearing Type	Rated Voltage	Operating Voltage	Input Current	Input Power	Speed	Max Air Flow		Max Static Pressure		Noise	Weight
Part No.	B.S	VDC	VDC	Amp	Watt	RPM	CFM	m <sup>3</sup> /min	Inch-H <sub>2</sub> O	Pa	dB-A	g
DA17251#12U	B	12	7.0~13.8	3.00	36.00	4000	305.29	8.65	1.14	283.51	67.0	740.0
DA17251#12H	B	12	7.0~13.8	2.00	24.00	3500	257.88	7.30	0.71	176.81	59.0	740.0
DA17251#12M	B	12	7.0~13.8	1.50	18.00	3000	220.85	6.25	0.52	128.57	51.0	740.0
DA17251#12L	B	12	7.0~13.8	1.00	12.00	2500	185.24	5.25	0.37	92.77	44.0	740.0
DA17251#24U	B	24	14.0~27.6	1.50	36.00	4000	305.29	8.65	1.14	283.51	67.0	740.0
DA17251#24H	B	24	14.0~27.6	1.00	24.00	3500	257.88	7.30	0.71	176.81	59.0	740.0
DA17251#24M	B	24	14.0~27.6	0.70	16.80	3000	220.85	6.25	0.52	128.57	51.0	740.0
DA17251#24L	B	24	14.0~27.6	0.50	12.00	2500	185.24	5.25	0.37	92.77	44.0	740.0
DA17251#48U	B	48	28.0~56.0	0.80	38.40	4000	305.29	8.65	1.14	283.51	67.0	740.0
DA17251#48H	B	48	28.0~56.0	0.60	28.80	3500	257.88	7.30	0.71	176.81	59.0	740.0
DA17251#48M	B	48	28.0~56.0	0.50	24.00	3000	220.85	6.25	0.52	128.57	51.0	740.0
DA17251#48L	B	48	28.0~56.0	0.40	19.20	2500	185.24	5.25	0.37	92.77	44.0	740.0

Specifications are subject to change without notice. Please visit our website at <http://www.szhxht.com> for update in formation

Dimensions (Unit:mm)

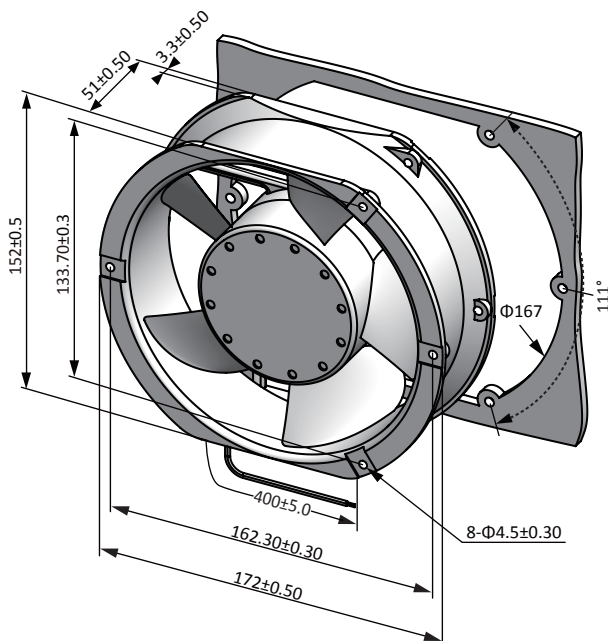

PQ Curve (At rated Voltage)

