

The TQ8025 is a non-blocking 16 x 16 digital crosspoint switch capable of data rates greater than 2.5 gigabits per second per port. With a fully differential internal data path and PECL/CML I/O, the TQ8025 offers an extremely high data rate with exceptional signal fidelity. The use of fully differential logic results in low crosstalk, jitter, and signal skew. The TQ8025 is ideally suited for digital video, data communications, telecommunication switching, and cross-connect applications.

The non-blocking architecture uses 16 fully independent 16:1 multiplexers which allow each output port to be independently programmed to any input port. The TQ8025 offers two programming options: a flexible port-by-port option, and a fast configuration option.

Using the fast configuration option, all 16 switch ports are programmed within 80ns by serially loading four 16-bit input port selection words. Two output pins (RADD0,1) are provided to drive an external RAM (n x 4 x 16 bits) used to store the switch configuration. An Autoconfigure option automatically transfers the new configurations into the switch core. Autoconfiguration occurs after the last input selection word is clocked into the programming registers.

Data integrity is maintained on all unchanged data paths for both the port-by-port and fast configuration options.

TQ8025

PRELIMINARY DATA SHEET

2.5 Gigabit/sec 16x16 Digital Crosspoint Switch

Features

- 16 PECL/CML fully differential (back-terminated) outputs
- >2.5 Gb/s data bandwidth per channel
- >40 Gb/s aggregate bandwidth
- Non-blocking architecture
- 80 ns configuration time
- Autonomous control of external RAM for configuration data
- Low jitter and signal skew
- ±100 ps delay match (one input to all outputs)
- Fully differential data path
- 132-pin MLC package with heat spreader

Applications

- SONET OC-48 data path
- Double-speed Fibre Channel
- Hubs and routers
- High-definition video switching
- Parallel processing

SWITCHING
PRODUCTS



TQ8025

PRELIMINARY DATA SHEET

Specifications

Table 1. Absolute Maximum Ratings ⁴

Storage temperature	T_{STORE}	-65 °C to +150 °C
Junction temperature	T_{CH}	150 °C
Case temperature with bias ¹	T_C	$T_J = 150$ °C
Supply voltage ²	V_{CC}	0 V to +7.0 V
Voltage to any input ²	V_{IN}	-0.5 V to $V_{CC} + 0.5$ V
Voltage to any output ²	V_{OUT}	-0.5 V to $V_{CC} + 0.5$ V
Current to any input ²	I_{IN}	-1.0 mA to +1.0 mA
Current from any output ²	I_{OUT}	40 mA
Power dissipation of output ³	P_{OUT}	50 mW

Notes: 1. T_C is measured at the case top.

2. All voltages are measured with respect to GND 0V and are continuous.

3. $P_{OUT} = (V_{CC} - V_{OUT}) \times I_{OUT}$.

4. Absolute maximum ratings in this table are those beyond which the device's performance may be impaired and/or permanent damage may occur.

Table 2. Recommended Operating Conditions ⁴

Symbol	Parameter	Min	Typ	Max	Units	Notes
T_C	Case Operating Temperature	0	—	85	°C	1, 3
V_{CC}	Supply Voltage	4.75	—	5.25	V	
V_{TT}	Load Termination Supply Voltage		$V_{CC} - 2.0$		V	2
I_{CC}	Current Positive Supply	—	—	2.1	A	
R_{LOAD}	Output Termination Load Resistance		50		Ω	2
Θ_{JC}	Thermal Resistance Channel to Case			4.5	°C/W	

Notes: 1. T_C measured at case top. Use of adequate heatsink is required.

2. The V_{TT} and R_{LOAD} combination is subject to maximum output current and power restrictions.

3. Contact the Factory for extended temperature range applications.

4. Functionality and/or adherence to electrical specifications is not implied when the device is subjected to conditions that exceed, singularly or in combination, the operating range specified.

Table 3. DC Characteristics — CML I/O⁵

Symbol	Description	Test Conditions	Min	Nom	Max	Unit
V _{COM}	Common mode voltage	(Note 1)	V _{CC} - 600	—	V _{CC}	mV
V _{DIFF}	Differential voltage	(Note 1)	400	—	1200	mV
V _{IH}	Input HIGH voltage	(Note 2)	—	—	V _{CC}	mV
V _{IL}	Input LOW voltage		V _{CC} - 1100	—	—	mV
V _{OH}	Output HIGH voltage	(Note 3)	V _{CC} - 100	—	V _{CC}	mV
V _{OL}	Output LOW voltage	(Note 3)	V _{CC} - 1100	—	V _{CC} - 600	mV
I _{OH}	Output HIGH current	(Note 3, 4)	20	23	30	mA
I _{OL}	Output LOW current	(Note 3, 4)	0	5	8	mA

Table 4. DC Characteristics — PECL I/O⁵

Symbol	Description	Test Conditions	Min	Nom	Max	Unit
V _{COM}	Common mode voltage	(Note 1)	V _{CC} - 1500	—	V _{CC} - 1100	mV
V _{DIFF}	Differential voltage	(Note 1)	400	—	1200	mV
V _{IH}	Input HIGH voltage	(Note 2)	—	—	V _{CC} - 500	mV
V _{IL}	Input LOW voltage		V _{CC} - 2100	—	—	mV
V _{OH}	Output HIGH voltage	(Note 3)	V _{CC} - 1100	—	V _{CC} - 600	mV
V _{OL}	Output LOW voltage	(Note 3)	V _{CC} - 2100	—	V _{CC} - 1600	mV
I _{OH}	Output HIGH current	(Note 4)	20	23	30	mA
I _{OL}	Output LOW current	(Note 4)	0	5	8	mA
C _{IN}	Input capacitance		—	—	TBD	pF
C _{OUT}	Output capacitance		—	—	TBD	pF
VESD	ESD breakdown rating	(Note 5)	Class I	—	—	

Table 5. DC Characteristics — TTL I/O⁵

Symbol	Description	Test Conditions	Min	Nom	Max	Unit
V _{IH}	Input HIGH voltage		2.0	—	V _{CC}	V
V _{IL}	Input LOW voltage		0	—	0.8	V
I _{IH}	Input HIGH current	V _(IHMAX)	—	—	200	μA
I _{IL}	Input LOW current	V _(ILMIN)	-400	-200	—	μA
V _{OH}	Output HIGH voltage	I _{OH} = 50 mA	2.4	—	V _{CC}	V
V _{OL}	Output LOW voltage	I _{OH} = -20 mA	0	—	0.4	V
C _{IN}	Input capacitance		—	—	TBD	pF
C _{OUT}	Output capacitance		—	—	TBD	pF
VESD	ESD breakdown rating	(Note 5)	Class I	—	—	

- Notes (Tables 3, 4, and 5):
1. Differential inputs.
 2. V_{REF} = 1300 mV.
 3. R_{LOAD} = 50 ohms to V_{TT} = V_{CC} - 2.0 V.
 4. Not tested; consistent with V_{OH} and V_{OL} tests.
 5. Specifications apply over recommended operating ranges.

TQ8025

PRELIMINARY DATA SHEET

Table 6. AC Characteristics

Symbol	Description	Test Conditions	Min	Typ	Max	Unit
T _{PW}	D(0:15) minimum pulse width	(Note 1)	360	—	—	ps
T _{R/F}	O(0:15) rise/fall time 20-80%	(Note 1)	—	—	150	ps
T _{PD}	D(0:15), O(0:15) delay time	(Note 1)	—	—	2.5	ns
T _{SKEW}	Path delay matching	(Note 1)	—	300	—	ps
T _{JITTER}	Jitter	(Note 2)	—	50	—	ps pk-pk

Notes: 1. Minimum V_{OH} to maximum V_{OL} levels.

2. Crossing of (On)—(NO_n) measured with 2²³ - 1 PRBS, measured over extended time.

Table 7. TQ8025 Timing — Normal Configure Mode¹

Symbol	Parameter	Min.	Max.	Units
T1	Hold LOAD low to SADO:3, DADO:3	2	—	ns
T2	Setup DADO:3 to LOAD high	0	—	ns
T3	CONFIGURE pulse low time	10	—	ns
T4	Setup LOAD low to CONFIGURE low	3	—	ns
T5	CONFIGURE low to SIGNAL PATHS updated	4	—	ns
T6	LOAD pulse width high	TBD	—	ns

Notes: 1. LD_{MODE} = 0; AUTO_{CONFIG} = Don't Care, RESET₋ = 1, CLOCK = Don't Care.

Figure 1. TQ8025 Timing — Normal Configure Mode

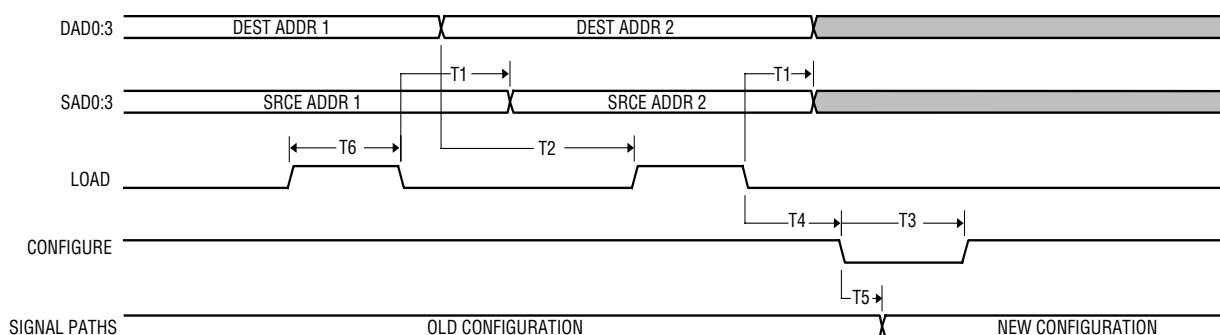

LD_{MODE}=0; AUTO_{CONFIG} = Don't Care, RESET₋ = 1, CLOCK = Don't Care.

Table 8. TQ8025 Timing — RAM Loading, Auto-Configure Mode ¹

Symbol	Parameter	Min.	Max.	Units
T1	LOAD high to READY low	3		ns
T2	CLOCK low to READY high	3		ns
T3	ADDREN low to RADD enabled	3		ns
T4	Setup LOAD high to CLOCK high	4		ns
T5	CLOCK low to RADD increment	2		ns
T6	AD0:15 setup before CLOCK low	0		ns
T7	AD0:15 hold time after CLOCK low	2		ns
T8	CLOCK low to INT CONFIGURE high	2		ns
T9	CONFIGURE low pulse width	10		ns
T10	ADDREN high to RADD tristate	3		ns
T11	LOAD low prior to 3rd CLOCK low	4		ns
T12	LOAD high pulse	TBD		ns
T13	CLOCK low to SIGNAL PATHS updated	4		ns
T14	CLOCK period	20		ns
T15	LOAD high to INT CONFIGURE low	TBD		ns

Notes: 1. LDMODE = 1; AUTOCONFIG = 1, RESET- = 1, CONFIG = 1.

Figure 2. TQ8025 Timing — RAM Loading, Auto-Configure Mode

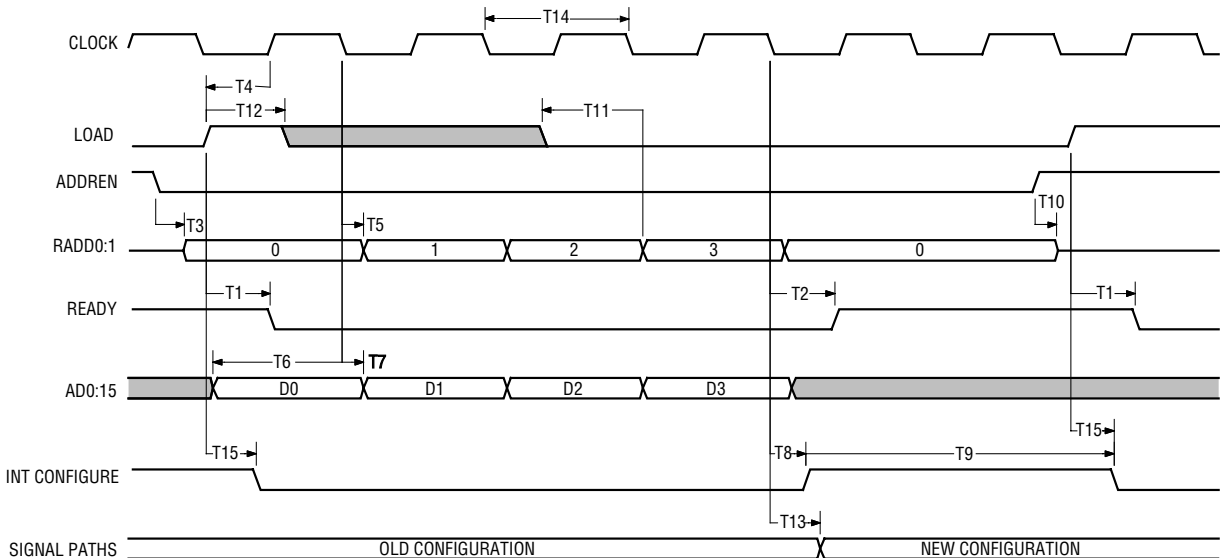

LDMODE = 1; AUTOCONFIG = 0, RESET- = 1.

Note: INT CONFIGURE is an internal signal shown for clarity of operation.

TQ8025

PRELIMINARY DATA SHEET

Table 9. TQ8025 Timing — RAM Loading, External Configure Pulse Mode ¹

Symbol	Parameter	Min.	Max.	Units
T1	LOAD high to READY low	3		ns
T2	CLOCK low to READY high	3		ns
T3	ADDREN low to RADD enabled	3		ns
T4	Setup LOAD high to CLOCK high	4		ns
T5	CLOCK low to RADD increment	2		ns
T6	AD0:15 setup before CLOCK low	0		ns
T7	AD0:15 hold time after CLOCK low	2		ns
T8	Setup last CLOCK before CONFIGURE low	2		ns
T9	CONFIGURE low pulse width	10		ns
T10	ADDREN high to RADD tristate	3		ns
T11	LOAD low prior to 3rd CLOCK low	4		ns
T12	LOAD high pulse	TBD		ns
T13	CONFIGURE low to READY low	TBD		ns
T14	CONFIGURE low to SIGNAL PATHS updated	4		ns
T15	CLOCK period	20		ns

Notes: 1. LDMODE = 1; AUTOCONFIG = 0, RESET- = 1.

Figure 3. TQ8025 Timing — RAM Loading, External Configure Pulse Mode

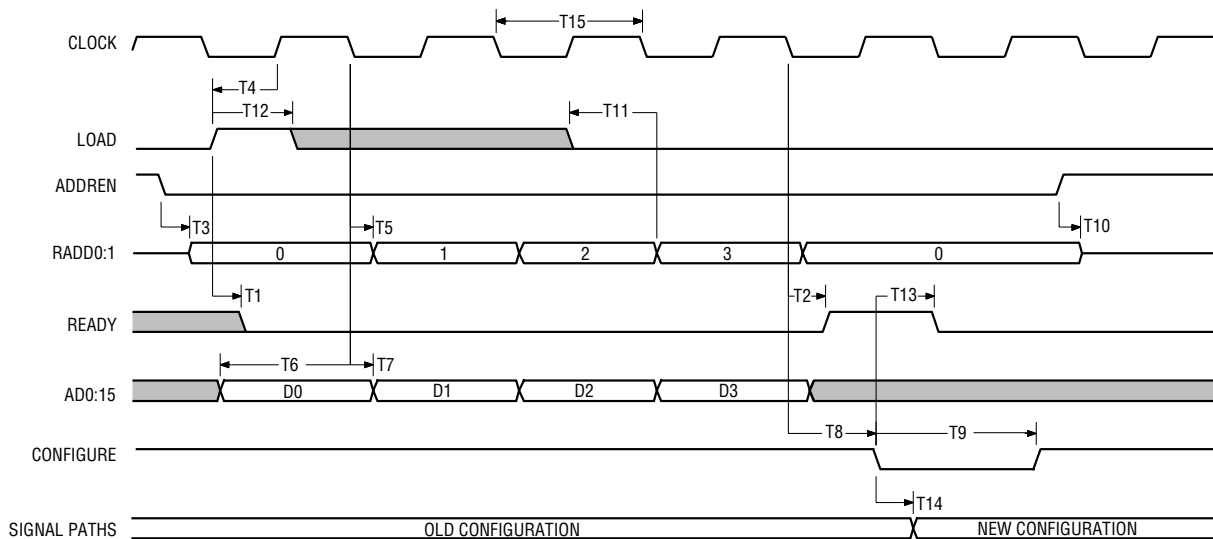

LDMODE = 1; AUTOCONFIG = 1, RESET- = 1, CONFIG = 1.

TQ8025

PRELIMINARY DATA SHEET

Typical Performance

Data Rate: 2.5Gb/s

Data Pattern: 2⁷ PRBS

Note: Measured jitter is 68ps pk-pk.
Signal source jitter is 32ps pk-pk.

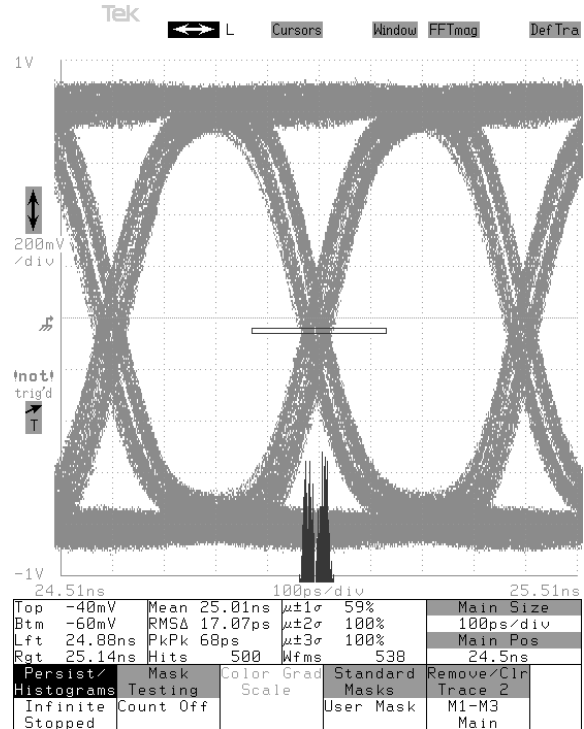

SWITCHING PRODUCTS

Rise and Fall

Data Rate: 2.5Gb/s

Rise Time: 115ps

Fall Time: 109ps

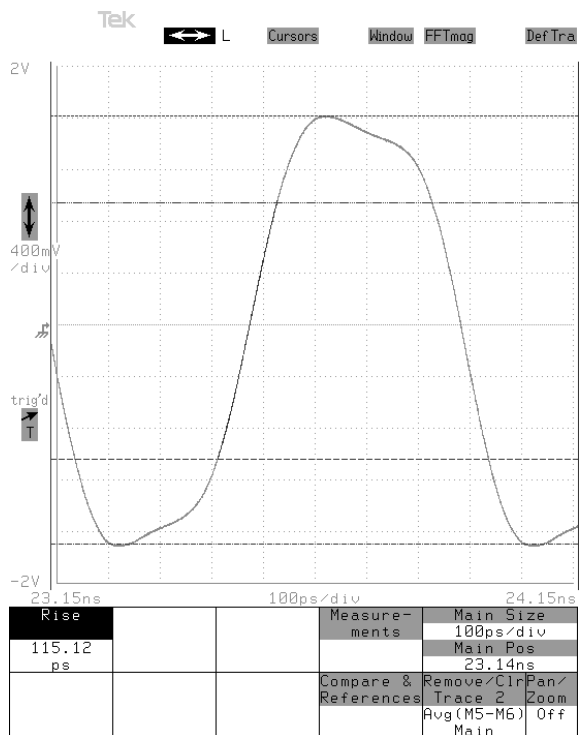

TQ8025

PRELIMINARY DATA SHEET

Figure 4. TQ8025 pinout — top view

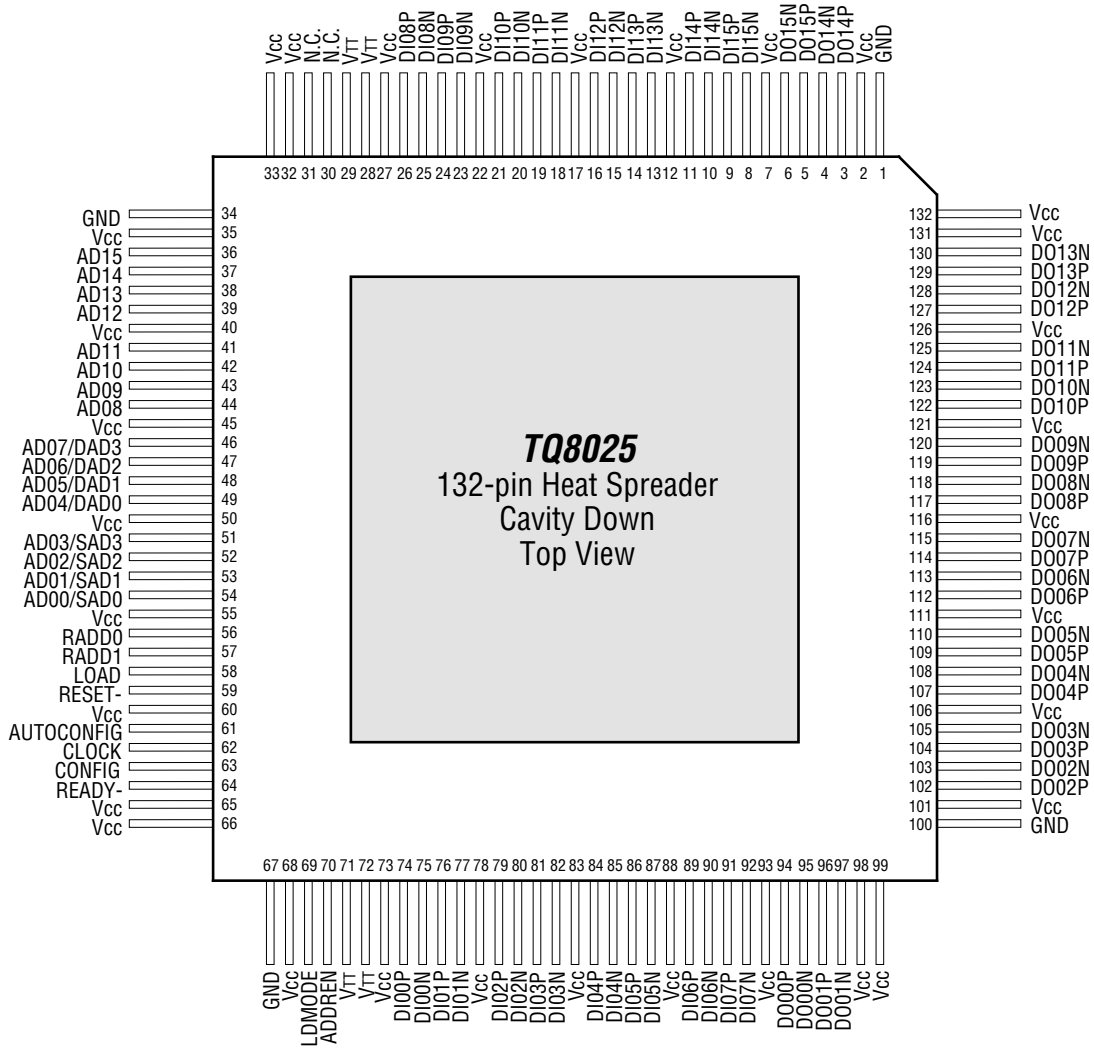

Table 10. TQ8025 Pin Descriptions

Signal	Name/Level	Description
DI00P-DI15P	Data input true and complement	Differential data input ports. $V_H = 0\text{ V}$, $V_L = -300\text{ mV max.}$
DION-DI15N	Differential CML/PECL input	Internal 50-ohm terminations to VTT (CML = 0 V; ECL = -2.0 V).
DO0P-DO15P, DO0N-DO15N	Data output true and complement Differential CML/PECL output	Differential data output ports. 600 mV min. differential swing.
AD00:15	Input address; TTL input	Serial input address, LSB first in time; ADn programs output port n.
RADD0:1	RAM address; TTL output, tristate	Used to generate address 0-3 during configure load from RAM.
ADDREN	Enable RADD0:2; TTL input	When low, enables RADD0:1; when high, forces RADD0:1 tristate.
CLOCK	Clock; TTL input	Controls cycle time of address generator and AUTOCONFIG.
AUTOCONFIG	Configure mode; TTL input	When high, internal CONFIGURE is automatically generated.
READY	READY; open-drain output	Indicates end of AUTOCONFIG or end of address LOAD cycle when high. Reset low by RESET-, CONFIG low, or LOAD rising. Requires external pullup to V_{CC} .
LOAD	LOAD; TTL input	For LDMODE=1, ADDREN=0: AUTOCONFIG=0, rising LOAD causes ADDR0:1 to generate RAM addresses, then READY is asserted after four clock ticks. For AUTOCONFIG=1, LOAD rising causes ADDR0:1 to generate addresses, causing an internal CONFIG to be generated, after which READY is asserted. For LDMODE=0, see SADO:3 and DADO:3.
CONFIGURE	CONFIGURE; TTL input	Used to load address contents of internal address registers. Active LOW. Crosspoint will be configured within 4 ns (objective) of CONFIG falling low.
LDMODE	Load Mode; TTL input	When floated high, AD0-15 are used for configuration. When tied low, SADO-3 and DADO-3 are used for configuration. When AUTOCONFIG is disabled, and AD08-15 are ignored.
SADO:3	Source Address; TTL inputs	When LDMODE is low, specifies input address to be connected to output port specified by DADO:3. Latched by falling LOAD (LDMODE=0).
DADO:3	Destination Address; TTL input	When LDMODE is low, specifies output address to be connected to input port specified by SADO:3. Latched by falling LOAD (LDMODE=0).
VCC, GND, VTT	+5V, Ground; Termination Voltage	Power and ground pins. $V_{TT} = \text{GND}$ for CML inputs; $V_{TT} = V_{CC} - 2\text{ V}$ for PECL inputs.
RESET-	Reset; TTL Input	While low, programs all output ports to connect to input port 0. Strobing CONFIG after reset restores user port programming if device power was stable since last user programming and during RESET-. Active low, Schmitt triggered.

TQ8025

PRELIMINARY DATA SHEET

Figure 5. Mechanical Dimensions

Bottom view

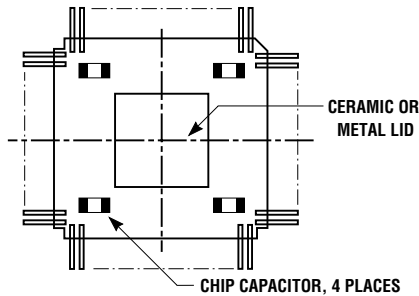

Section A-A

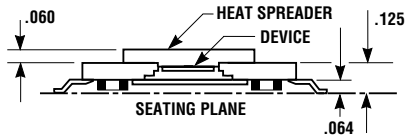

Top view

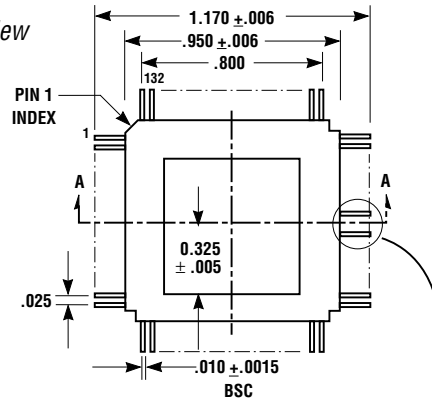

1. Part is symmetrical about the center axes.
2. Centerline bisects center pin in both directions.
3. See pad detail below.

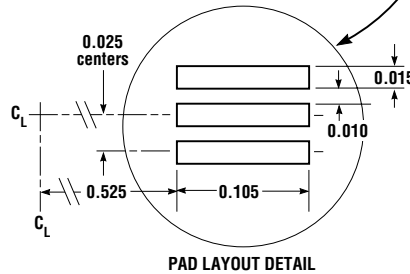

Ordering Information

TQ8025

2.5 Gb/s 16x16 Crosspoint Switch

Additional Information

For latest specifications, additional product information, worldwide sales and distribution locations, and information about TriQuint:

Web: www.triquint.com **Tel:** (503) 615-9000

Email: sales@tqs.com **Fax:** (503) 615-8900

For technical questions and additional information on specific applications:

Email: applications@tqs.com

The information provided herein is believed to be reliable; TriQuint assumes no liability for inaccuracies or omissions. TriQuint assumes no responsibility for the use of this information, and all such information shall be entirely at the user's own risk. Prices and specifications are subject to change without notice. No patent rights or licenses to any of the circuits described herein are implied or granted to any third party. TriQuint does not authorize or warrant any TriQuint product for use in life-support devices and/or systems.

Copyright © 1998 TriQuint Semiconductor, Inc. All rights reserved.

Revision 0.3.A August 1998