



WINSTAR Display Co.,Ltd.
華凌光電股份有限公司



Winstar Display Co., LTD

華凌光電股份有限公司



WEB: <http://www.winstar.com.tw> E-mail: sales@winstar.com.tw

SPECIFICATION

CUSTOMER : _____

MODULE NO.: WF18FTLAADNNO#

<p>APPROVED BY:</p> <p>(FOR CUSTOMER USE ONLY)</p>	<p>PCB VERSION: _____</p> <p>DATA: _____</p>
---	--

SALES BY	APPROVED BY	CHECKED BY	PREPARED BY
			葉虹蘭
ISSUED DATE: 2017/12/15			

RECORDS OF REVISION			DOC. FIRST ISSUE
VERSION	DATE	REVISED PAGE NO.	SUMMARY
0	2017/09/28		First issue
A	2017/12/15		Modfiy Summary.

Contents

- 1.Module Classification Information
- 2.Summary
- 3.General Specification
- 4.Absolute Maximum Ratings
- 5.Electrical Characteristics
- 6.Data Color Coding
- 7.Optical Characteristics
- 8.Interface
- 9.Reliability
- 10.Contour Drawing
- 11.Other

1.Module Classification Information

W F 18 F T L A A D N N 0 #
 ① ② ③ ④ ⑤ ⑥ ⑦ ⑧ ⑨ ⑩ ⑪ ⑫ ⑬

①	Brand : WINSTAR DISPLAY CORPORATION											
②	Display Type : F→TFT Type, J→Custom TFT											
③	Display Size : 1.8" TFT											
④	Model serials no.											
⑤	Backlight Type :	F→CCFL, White S→LED, High Light White				T→LED, White Z→Nichia LED, White						
⑥	LCD Polarize Type/ Temperature range/ Gray Scale Inversion Direction	A→Transmissive, N.T, IPS TFT C→Transmissive, N. T, 6:00 ; F→Transmissive, N.T,12:00 ; I→Transmissive, W. T, 6:00 K→Transflective, W.T,12:00 L→Transmissive, W.T,12:00 N→Transmissive, Super W.T, 6:00				Q→Transmissive, Super W.T, 12:00 R→Transmissive, Super W.T, O-TFT V→Transmissive, Super W.T, VA TFT X→Transmissive, W.T, VA TFT Y→Transmissive, W.T, IPS TFT Z→Transmissive, W.T, O-TFT						
⑦	A : TFT LCD B : TFT+FR+CONTROL BOARD C : TFT+FR+A/D BOARD D : TFT+FR+A/D BOARD+CONTROL BOARD E : TFT+FR+POWER BOARD					F : TFT+CONTROL BOARD G : TFT+FR H : TFT+D/V BOARD I : TFT+FR+D/V BOARD J : TFT+POWER BD						
⑧	Resolution:											
	A	128160	B	320234	C	320240	D	480234	E	480272	F	640480
	G	800480	H	1024600	I	320480	J	240320	K	800600	L	240400
	M	1024768	N	128128	P	1280800	Q	480800	R	640320	S	480128
	T	800320	U	8001280	V	176220	W	1280398	X	1024250	Y	1920720
	Z	800200	2	1024324	3	7201280						
⑨	D: Digital L : LVDS M:MIPI											
⑩	Interface : N:without control board A:8Bit B:16Bit H: HDMI I:I2C Interface R:RS232 S:SPI Interface U:USB											
⑪	TS : N : Without TS T : resistive touch panel C : capacitive touch panel (G-F-F) G : capacitive touch panel(G-G)											
⑫	Version											
⑬	Special Code	#:Fit in with ROHS directive regulations										

2.Summary

WF18F is a color active matrix thin film transistor (TFT) liquid crystal display with polarizer.

This model is composed of amorphous silicon TFT as a switching device. It is a transmissive type display operating in the normally white mode.

This TFT LCD has a 1.77-inch diagonally measured active display area with 384 x 160 dot (128 vertical by 160 horizontal pixel) resolution. Each pixel is divided into Red, Green, Blue dots which are arranged in vertical stripes.

3. General Specifications

Item	Dimension	Unit
Size	1.77	inch
Dot Matrix	128 x RGB x 160(TFT)	dots
Module dimension	34.0(W) x 45.83(H) x 2.65(D)	mm
Active area	28.03 x 35.04	mm
Dot pitch	0.073 x 0.219	mm
LCD type	TFT, Normally White, Transmissive	
View Direction	6 o'clock	
Gray Scale Inversion Direction	12 o'clock	
Aspect Ratio	Portrait	
IC	ST7735S	
Backlight Type	LED, Normally White	
With /Without TP	Without TP	
Surface	Anti-Glare	

*Color tone slight changed by temperature and driving voltage.

4. Absolute Maximum Ratings

Item	Symbol	Min	Typ	Max	Unit
Operating Temperature	TOP	-20	—	+70	°C
Storage Temperature	TST	-30	—	+80	°C

Note: Device is subject to be damaged permanently if stresses beyond those absolute maximum ratings listed above

1. Temp. $\leq 60^{\circ}\text{C}$, 90% RH MAX. Temp. $> 60^{\circ}\text{C}$, Absolute humidity shall be less than 90% RH at 60°C

5. Electrical Characteristics

5.1. Operating conditions:

Item	Symbol	Condition	Min	Typ	Max	Unit
Supply Voltage For Analog	VCI	—	2.5	2.75	4.8	V
Interface Operation Voltage	IOVCC	—	1.65	1.8	3.7	V
Supply LCM current	ICI(mA)	—	-	0.9	2	mA

5.2. LED driving conditions

Parameter	Symbol	Min.	Typ.	Max.	Unit	Remark
LED current		-	40	-	mA	
Power Consumption			128	-	mW	
LED voltage	VBL+	2.9	3.2	3.4	V	Note 1
LED Life Time		-	50,000	-	Hr	Note 2,3,4

Note 1 : There are 1 Groups LED

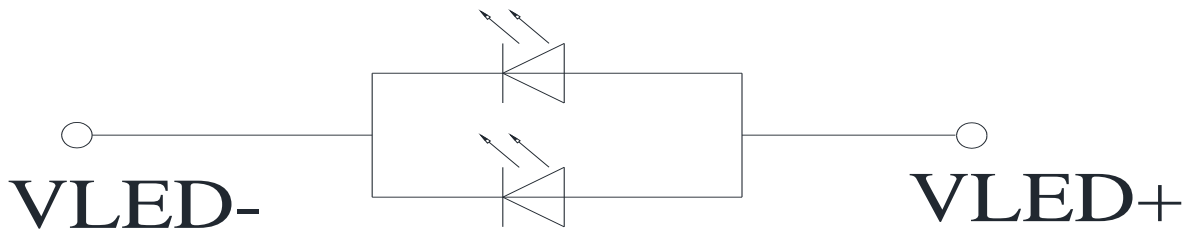

Note 2 : $T_a = 25\text{ }^\circ\text{C}$

Note 3 : Brightness to be decreased to 50% of the initial value

Note 4 : The single LED lamp case

6.Data Color Coding

6.1. 8-bit Parallel Interface (IM2, IM1, IM0= "100")

Different display data formats are available for three Colors depth supported by listed below.

- 4k Colors, RGB 4,4,4-bit Input.
- 65k Colors, RGB 5,6,5-bit Input.
- 262k Colors, RGB 6,6,6-bit Input.

8-bit Data Bus for 12-bit/Pixel (RGB 4-4-4-bit Input), 4K-Colors, 3AH= "03h"

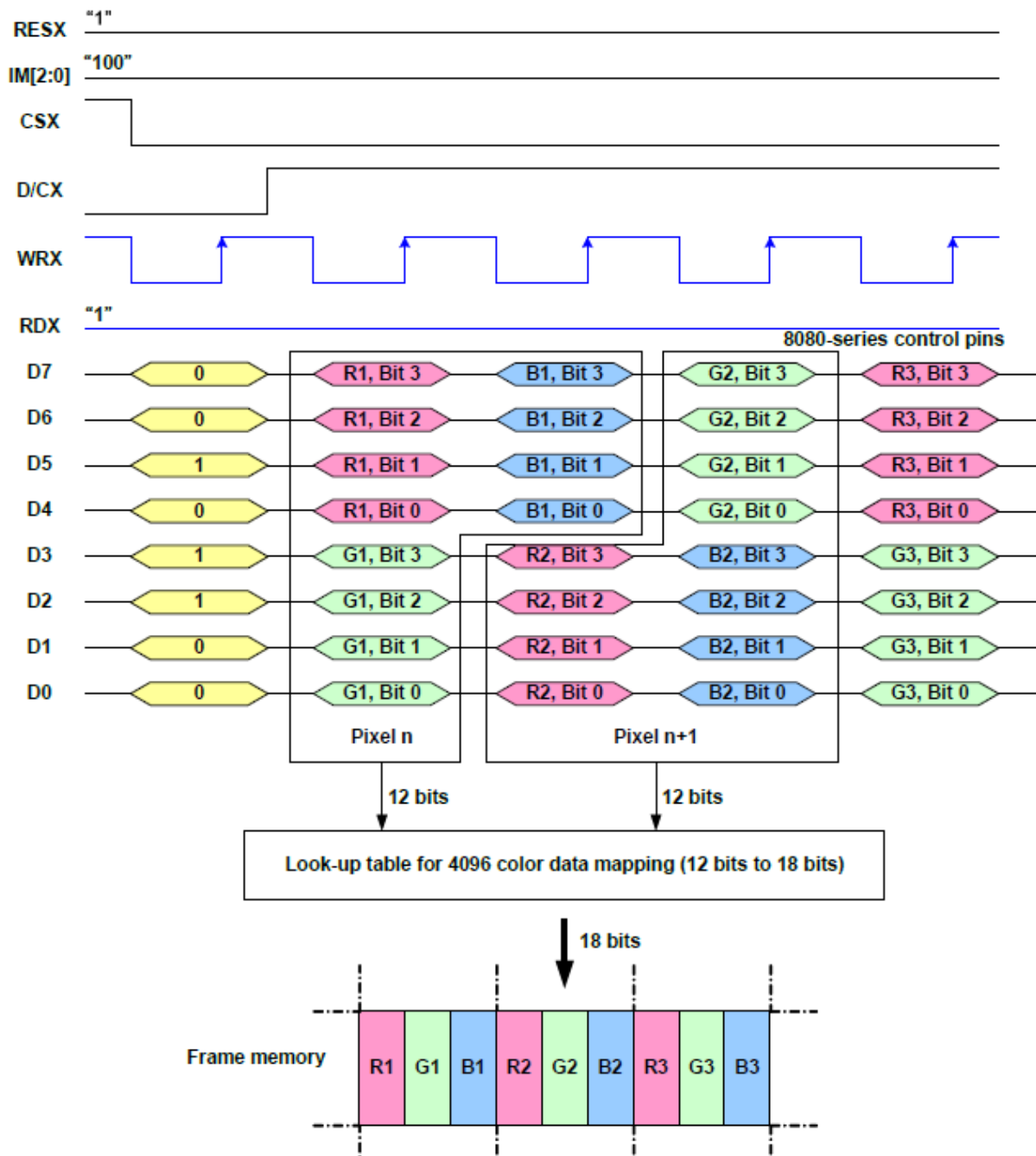

Note1: The data order is as follows, MSB=D7, LSB=D0 and picture data is MSB=Bit 3, LSB=Bit 0 for Red, Green and Blue data.

Note 2: 3-timetransfer is used to transmit 1 pixel data with the 12-bit color depth information.

Note 3: '-' = Don't care -Can be set to '0' or '1'

8-bit Data Bus for 16-bit/Pixel (RGB 5-6-5-bit Input), 65K-Colors, 3AH= "05h"

There is 1 pixel (3 sub-pixels) per 2-byte

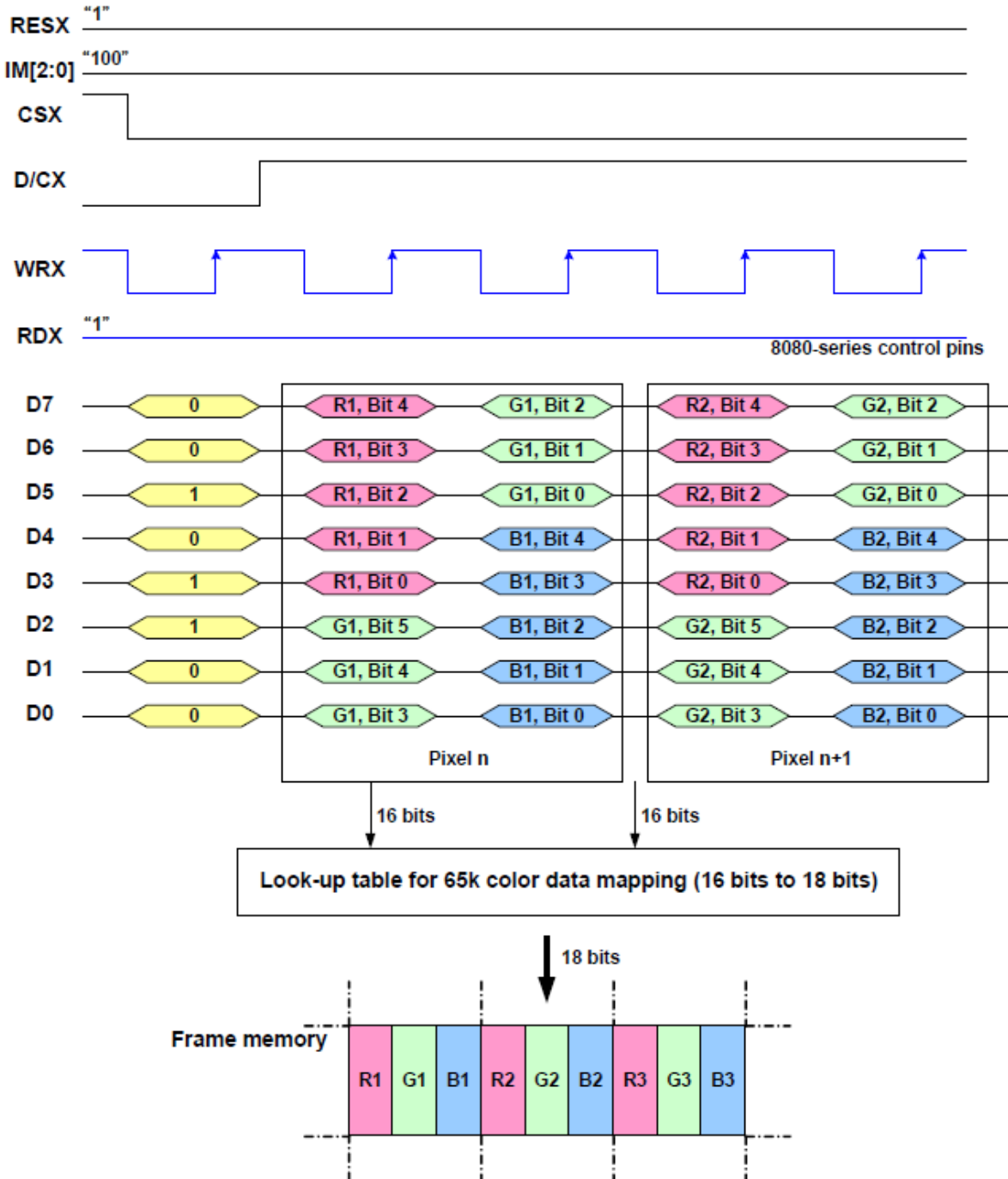

Note1: The data order is as follows, MSB=D7, LSB=D0 and picture data is MSB=Bit 5, LSB=Bit 0 for Green and MSB=Bit 4, LSB=Bit 0 for Red and Blue data.

Note 2: 2-times transfer is used to transmit 1 pixel data with the 16-bit color depth information.

Note 3: '-' = Don't care -Can be set to '0' or '1'

8-bit Data Bus for 18-bit/Pixel (RGB 6-6-6-bit Input), 262K-Colors, 3AH= "06h"

There is 1 pixel (3 sub-pixels) per 3-bytes.

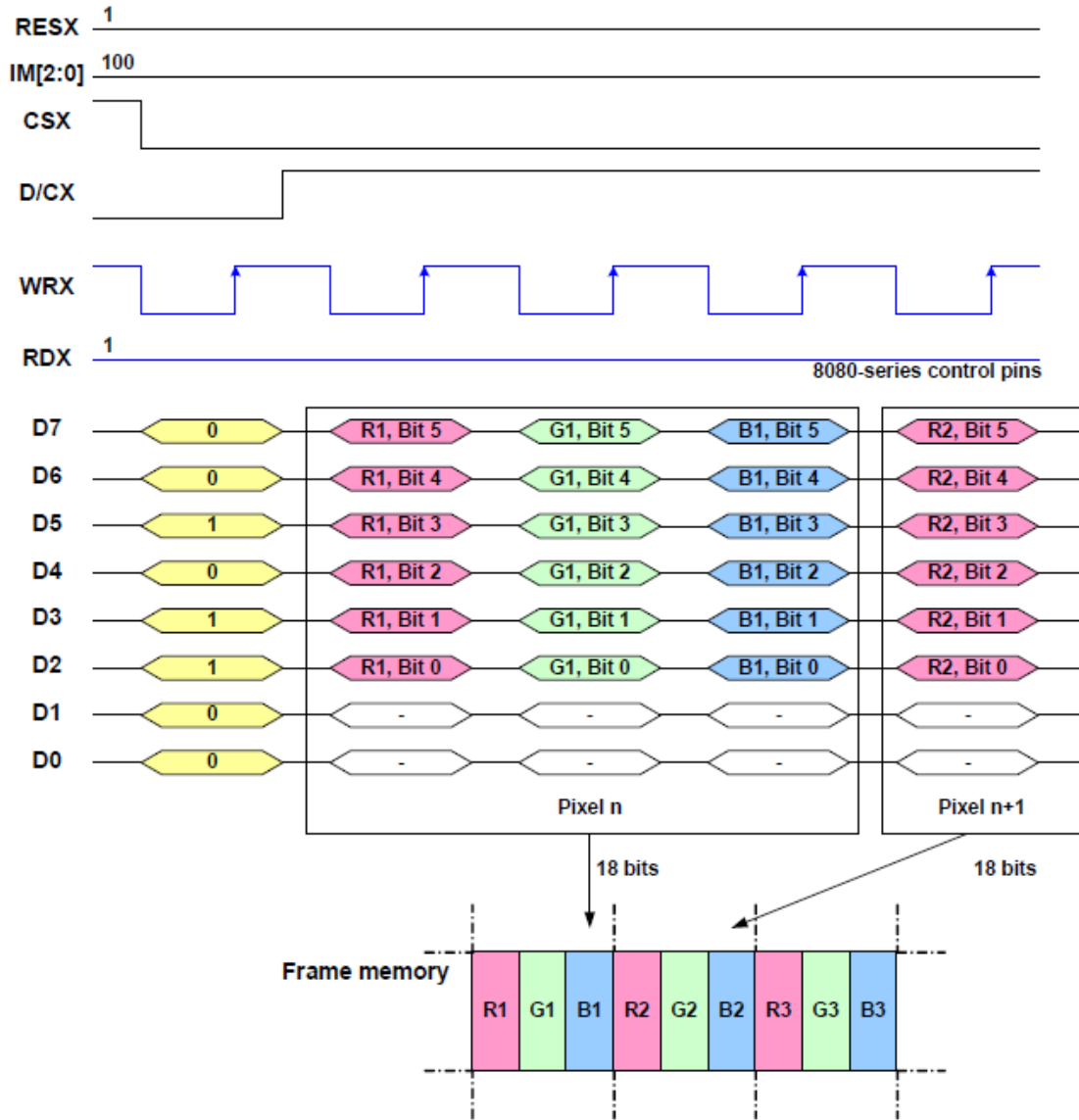

Note 1: The data order is as follows, MSB=D7, LSB=D0 and picture data is MSB=Bit 5, LSB=Bit 0 for Red, Green and Blue data.

Note 2: 3-times transfer is used to transmit 1 pixel data with the 18-bit color depth information.

Note 3: '-' = Don't care - Can be set to '0' or '1'

6.2. 16-Bit Parallel Interface (IM2,IM1, IM0= "101")

Different display data formats are available for three colors depth supported by listed below.

- 4k Colors, RGB 4,4,4-bit Input
- 65k Colors, RGB 5,6,5-bit Input
- 262k Colors, RGB 6,6,6-bit Input

16-bit Data Bus for 12-bit/Pixel (RGB 4-4-4-bit Input), 4K-Colors, 3AH= "03h"

There is 1 pixel (3 sub-pixels) per 1 byte

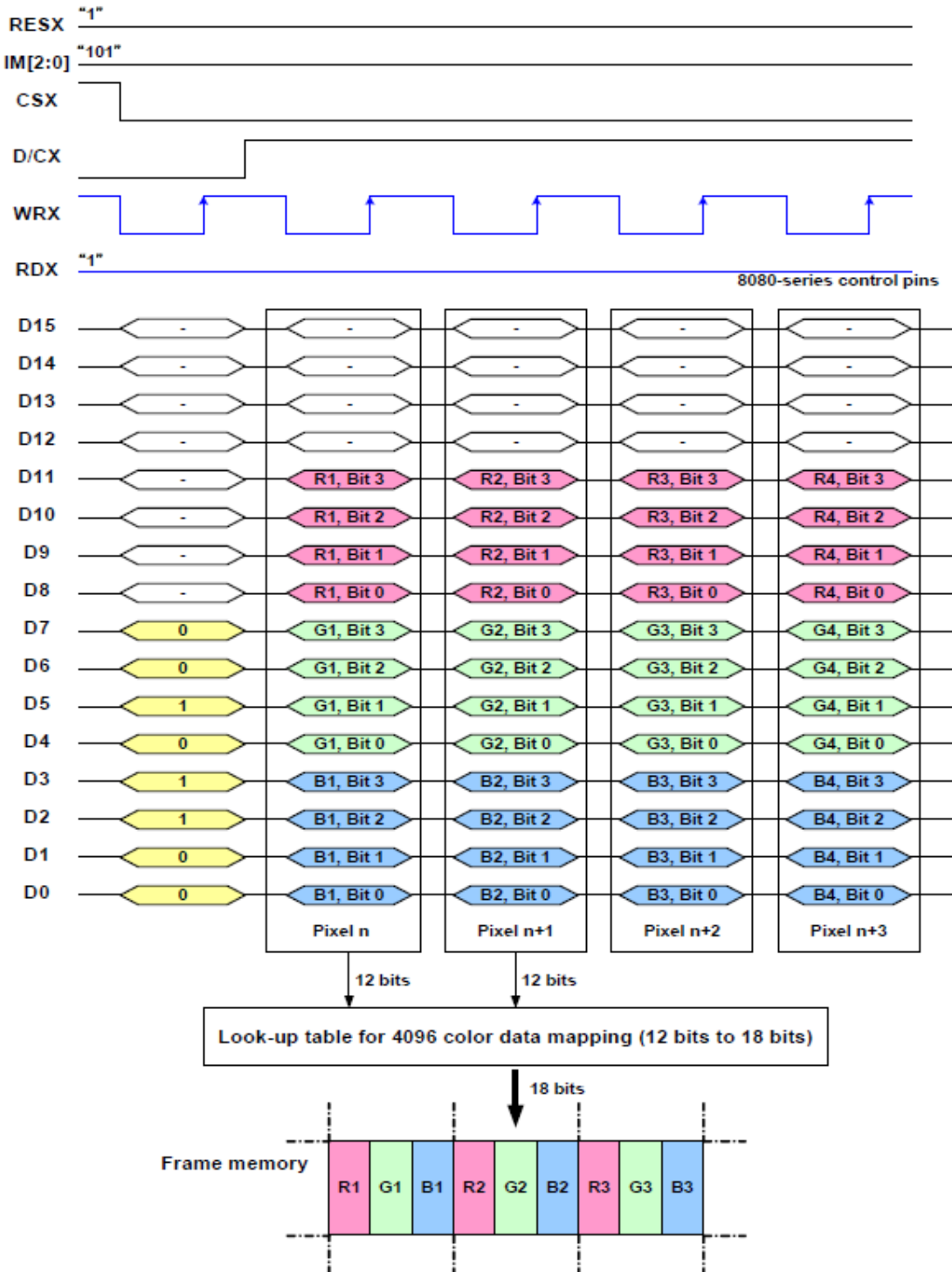

Note1: The data order is as follows, MSB=D11, LSB=D0 and picture data is MSB=Bit 3, LSB=Bit 0 for Red, Green and Blue data.

Note 2: 1-times transfer (D11 to D0) is used to transmit 1 pixel data with the 12-bit color depth information.

16-bit Data Bus for 16-bit/Pixel (RGB 5-6-5-bit Input), 65K-Colors, 3AH= "05h"

There is 1 pixel (3 sub-pixels) per 1 byte

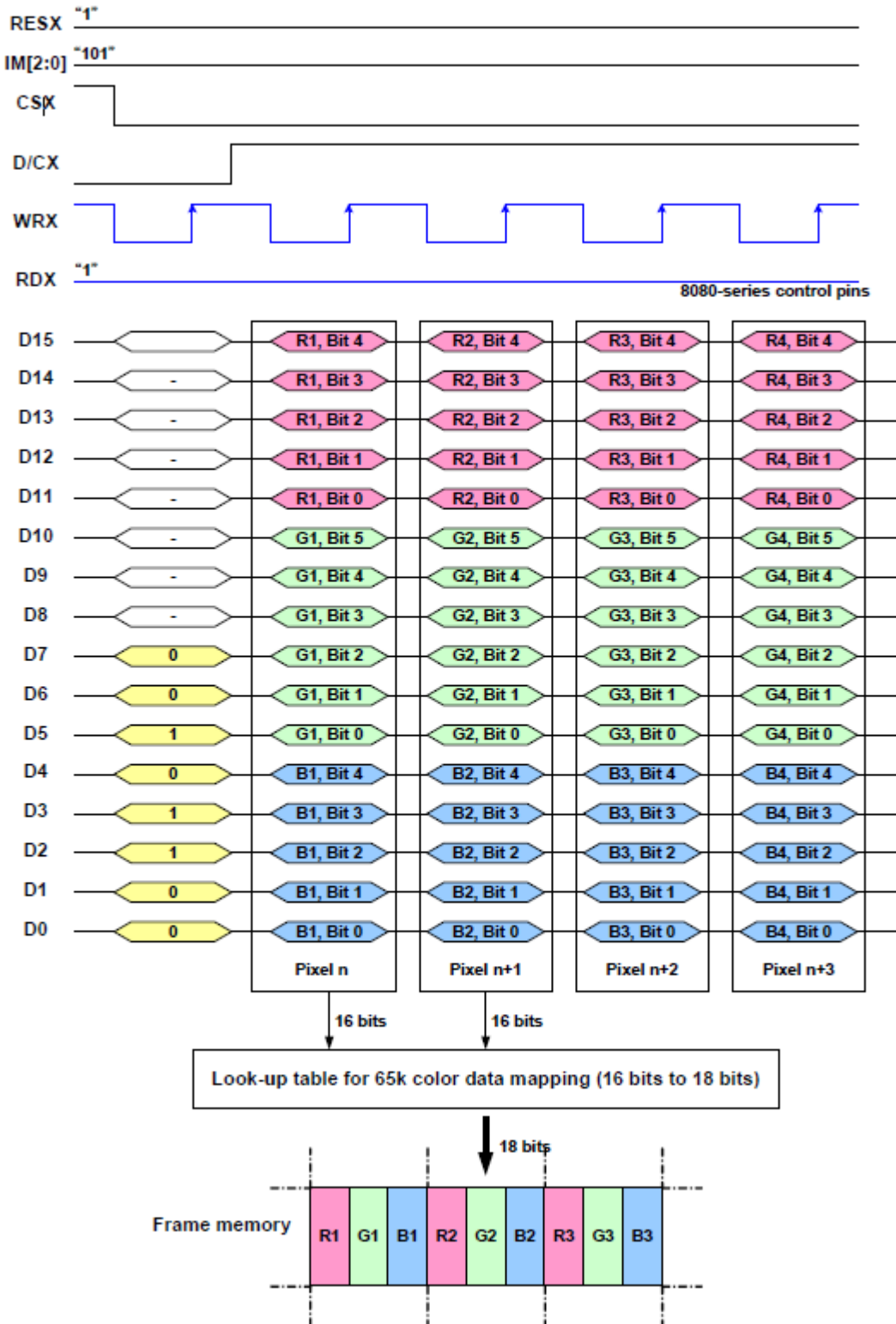

Note1: The data order is as follows, MSB=D15, LSB=D0 and picture data is MSB=Bit 5, LSB=Bit 0 for Green, and MSB=Bit 4, LSB=Bit 0 for Red and Blue data.

Note 2: 1-times transfer (D15 to D0) is used to transmit 1 pixel data with the 16-bit color depth information.

Note 3: '-' = Don't care -Can be set to '0' or '1'

16-bit Data Bus for 18-bit/Pixel (RGB 6-6-6-bit Input), 262K-Colors, 3AH= "06h"

There are 2 pixels (6 sub-pixels) per 3 bytes

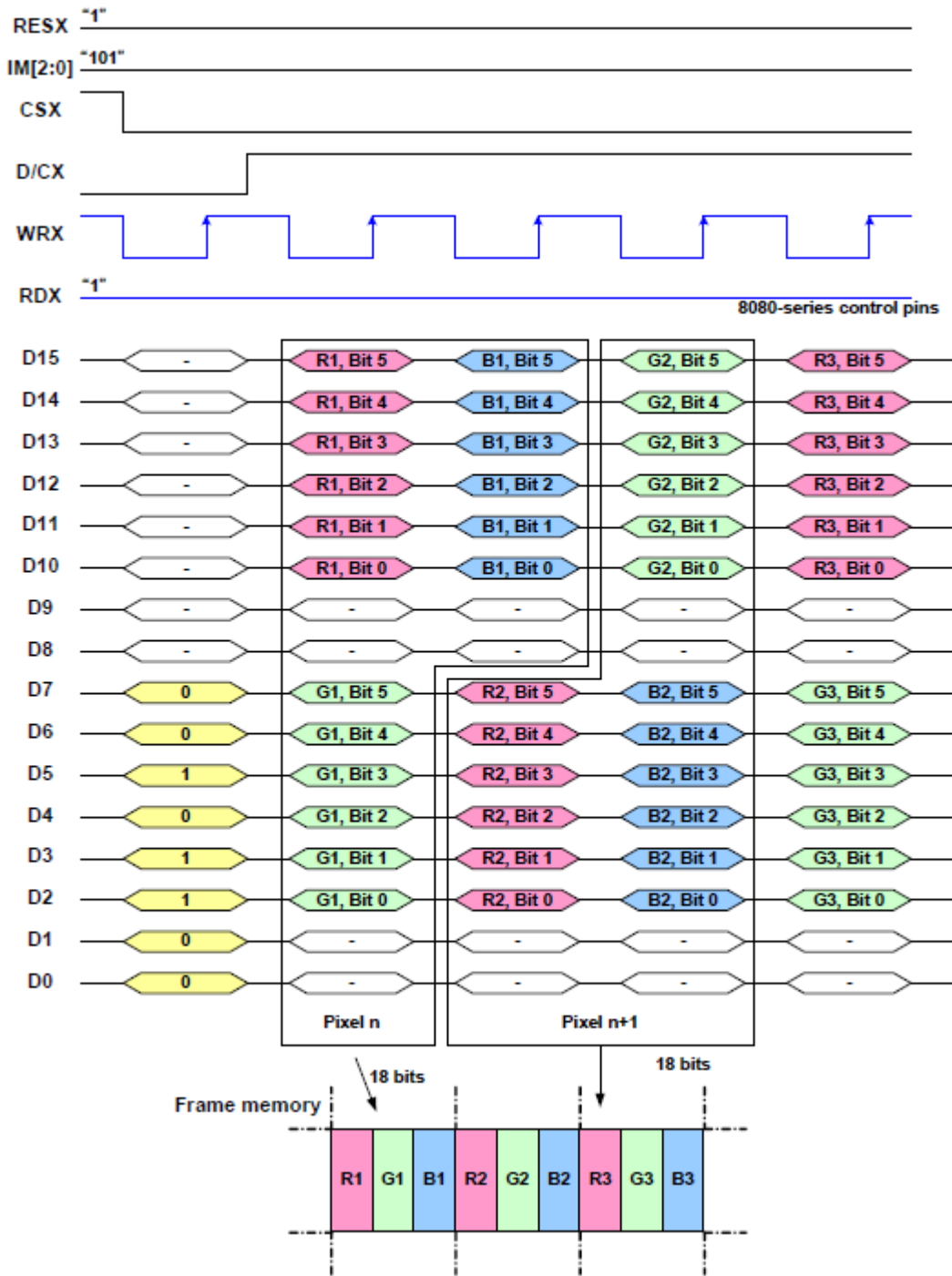

Note 1: The data order is as follows, MSB=D15, LSB=D0 and picture data is MSB=Bits 5, LSB=Bit 0 for Red, Green and Blue data.

Note 2: 3-times transfer is used to transmit 1 pixel data with the 18-bit color depth information.

Note 3: '-' = Don't care -Can be set to '0' or '1'

6.3. 3-line Serial Interface

Different display data formats are available for three colors depth supported by the LCM listed below.

4k Colors, RGB 4-4-4-bit Input

65k Colors, RGB 5-6-5-bit Input

262k Colors, RGB 6-6-6-bit Input

Write Data for 12-bit/Pixel (RGB 4-4-4-bit Input), 4K-Colors, 3AH="03h"

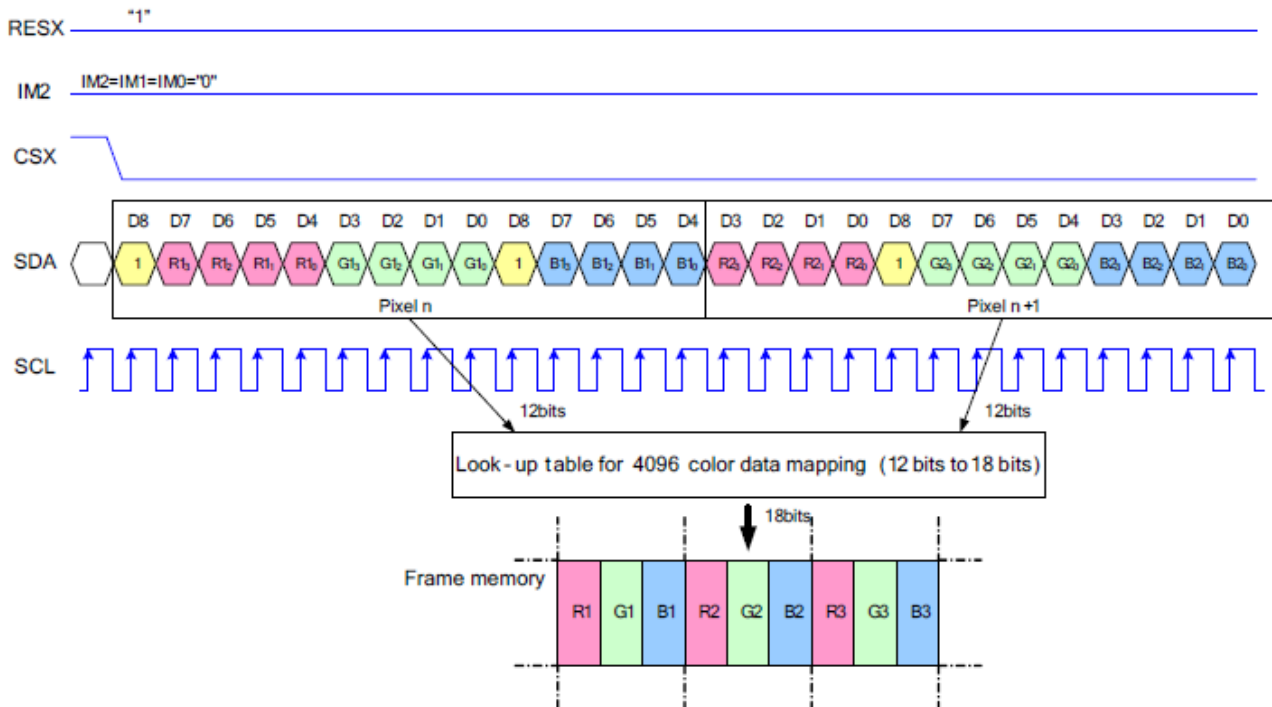

Note 1: Pixel data with the 12-bit color depth information

Note 2: The most significant bits are: Rx3, Gx3 and Bx3

Note 3: The least significant bits are: Rx0, Gx0 and Bx0

Write Data for 16-bit/Pixel (RGB 5-6-5-bit Input), 65K-Colors, 3AH="05h"

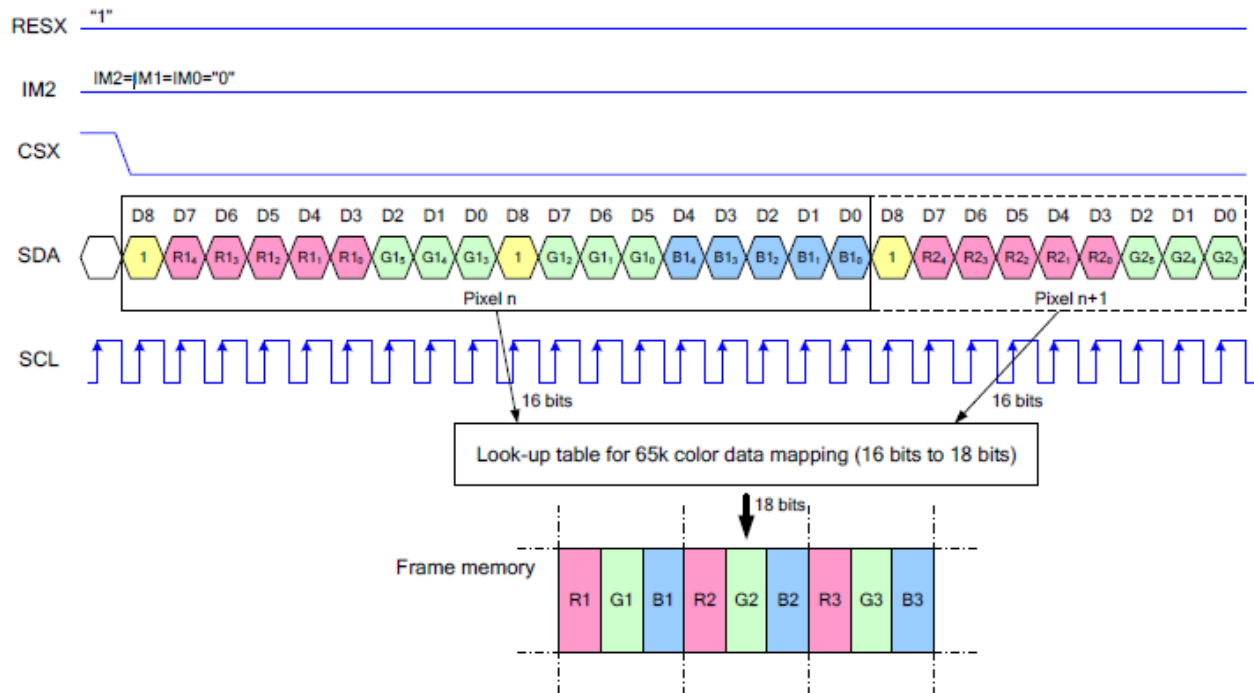

- Note 1: Pixel data with the 16-bit color depth information
- Note 2: The most significant bits are: Rx4, Gx5 and Bx4
- Note 3: The least significant bits are: Rx0, Gx0 and Bx0

Write Data for 18-bit/Pixel (RGB 6-6-6-bit Input), 262K-Colors, 3AH="06h"

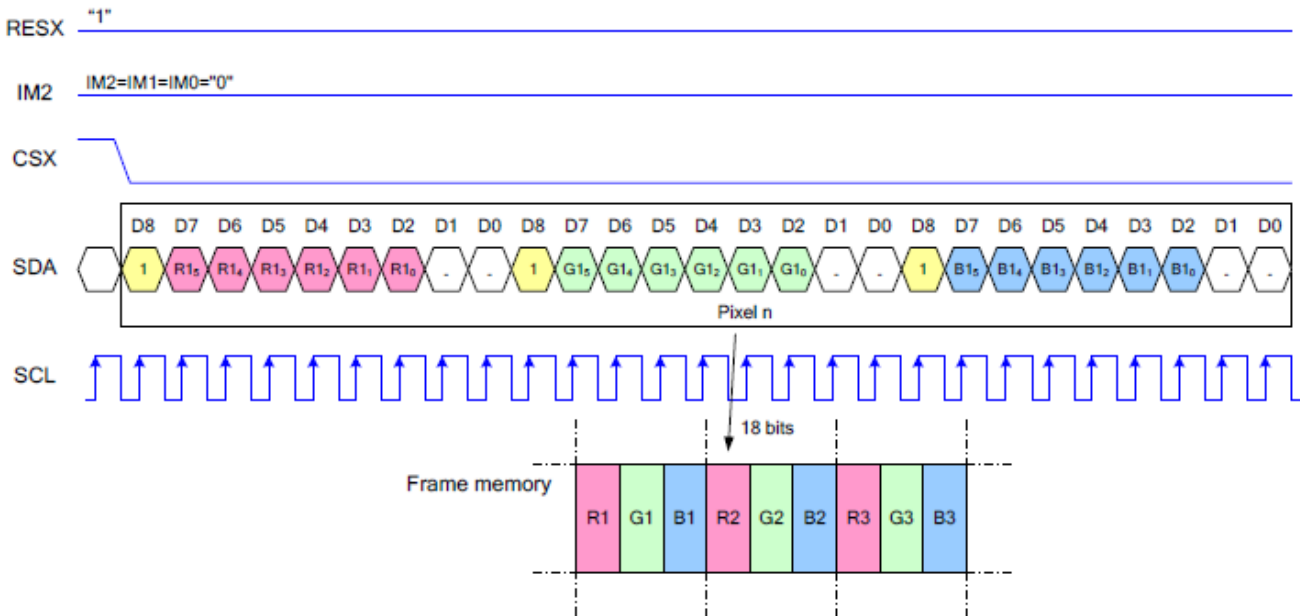

- Note 1: Pixel data with the 18-bit color depth information
- Note 2: The most significant bits are: Rx5, Gx5 and Bx5
- Note 3: The least significant bits are: Rx0, Gx0 and Bx0

7. Optical Characteristics

Item	Symbol	Condition.	Min	Typ.	Max.	Unit	Remark
Response time	Tr	$\theta=0^\circ$ 、 $\phi=0^\circ$	-	2	4	.ms	Note 3,5
	Tf			6	12		
Contrast ratio	CR	At optimized viewing angle	400	500	-	-	Note 4,5
Color Chromaticity	White	$\theta=0^\circ$ 、 $\phi=0^\circ$	0.26	0.31	0.36		Note 2,6,7
				0.28	0.33		
Viewing angle (Gray Scale Inversion Direction)	Hor.	Θ_R	$CR \geq 10$	35	45	Deg.	Note 1
		Θ_L		35	45		
	Ver.	Φ_T		35	45		
		Φ_B		10	20		
Brightness	-	-	450	500	-	Cd/m ²	Center of display

Ta=25±2°C

Note 1: Definition of viewing angle range

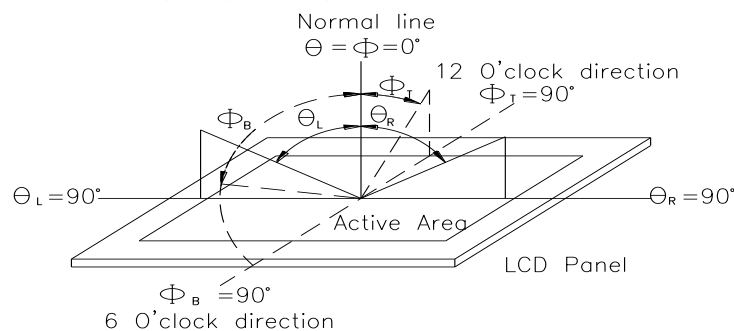

Fig.7.1. Definition of viewing angle

Note 2: Test equipment setup:

After stabilizing and leaving the panel alone at a driven temperature for 10 minutes, the measurement should be executed. Measurement should be executed in a stable, windless, and dark room. Optical specifications are measured by Topcon BM-7orBM-5 luminance meter 1.0° field of view at a distance of 50cm and normal direction.

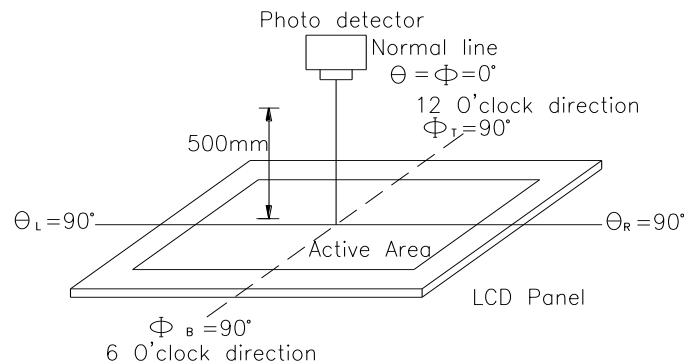
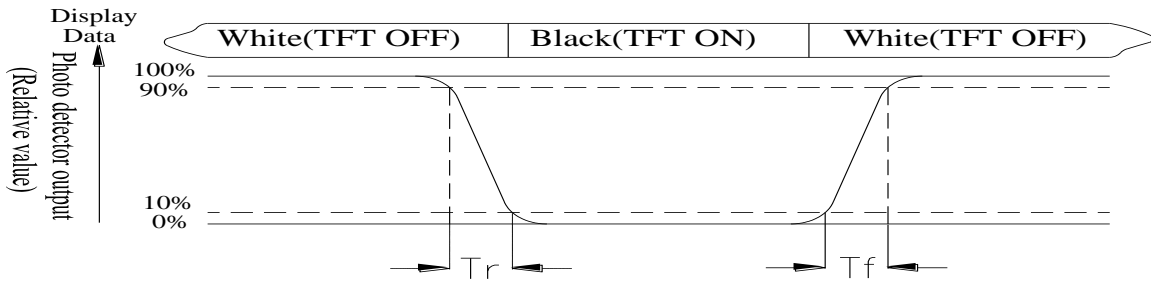

Fig. 7.2. Optical measurement system setup

Note 3: Definition of Response time:

The response time is defined as the LCD optical switching time interval between “White” state

and “Black” state. Rise time, T_r , is the time between photo detector output intensity changed from 90% to 10%. And fall time, T_f , is the time between photo detector output intensity changed from 10% to 90%



Note 4: Definition of contrast ratio:

The contrast ratio is defined as the following expression.

$$\text{Contrast ratio (CR)} = \frac{\text{Luminance measured when LCD on the "White" state}}{\text{Luminance measured when LCD on the "Black" state}}$$

Note 5: White $V_i = V_{i50} \pm 1.5V$

Black $V_i = V_{i50} \pm 2.0V$

“±” means that the analog input signal swings in phase with VCOM signal.

“±” means that the analog input signal swings out of phase with VCOM signal.

The 100% transmission is defined as the transmission of LCD panel when all the input terminals of module are electrically opened.

Note 6: Definition of color chromaticity (CIE 1931)

Color coordinates measured at the center point of LCD

Note 7: Measured at the center area of the panel when all the input terminals of LCD panel are electrically opened.

8.Interface

8.1. LCM PIN Definition

Pin	Symbol	I/O	Function	Remark															
1	VLED-	P	Back light cathode																
2	VLED+	P	Back light anode																
3	IM0	I	- MCU Parallel Interface Type Selection -If Not Used, Please Fix this Pin at VDDI or DGND Level.																
4	IM1																		
			<table border="1"> <thead> <tr> <th>IM1</th> <th>IM0</th> <th>Parallel Interface</th> </tr> </thead> <tbody> <tr> <td>0</td> <td>0</td> <td>MCU 8-bit Parallel</td> </tr> <tr> <td>0</td> <td>1</td> <td>MCU 16-bit Parallel</td> </tr> <tr> <td>1</td> <td>0</td> <td>MCU 9-bit Parallel</td> </tr> <tr> <td>1</td> <td>1</td> <td>MCU 18-bit Parallel</td> </tr> </tbody> </table>	IM1	IM0	Parallel Interface	0	0	MCU 8-bit Parallel	0	1	MCU 16-bit Parallel	1	0	MCU 9-bit Parallel	1	1	MCU 18-bit Parallel	
IM1	IM0	Parallel Interface																	
0	0	MCU 8-bit Parallel																	
0	1	MCU 16-bit Parallel																	
1	0	MCU 9-bit Parallel																	
1	1	MCU 18-bit Parallel																	
5	IM2	I	MCU Parallel Interface Bus and Serial Interface select IM2='1', Parallel Interface IM2='0', Serial Interface																
6	RESET	P	Reset signal																
7-12	NC	-	No Connect																
13-28	DB15-DB0(SPI_SDA)	I/O	DB15:0] are used as MCU parallel interface data bus. -DBis the serial input/output signal in serial interface mode. -In serial interface, DB15:1] are not used and should be fixed at VDDI or DGND level.																
29	NC	-	No Connect																
30	RD	I	Read Enable in 8080 MCU Parallel Interface. -If not used, please fix this pin at VDDI or DGND level.																
31	WR	I	Serial clock -Write Enable in MCU Parallel Interface. -If not used, please fix this pin at VDDI or DGND level.																
32	D/C(SPI_SCL)	I	-Display data/command Selection Pin in MCU Interface. -D/CX='1': Display Data or Parameter. -D/CX='0': Command Data. -In Serial Interface, this is used as SCL. -If not used, please fix this pin at VDDI or DGND level.																
33	CS(SPI_CS)	I	Chip enable																
34	IOVCC	P	Interface Operation Voltage																
35	VCI	P	Analog Supply Voltage																
36	GND	P	Ground																
37-40	NC	-	No Connect																

9. Reliability

Content of Reliability Test (Wide temperature, -20°C ~70°C)

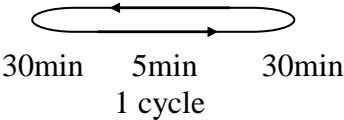
Environmental Test			
Test Item	Content of Test	Test Condition	Note
High Temperature storage	Endurance test applying the high storage temperature for a long time.	80°C 200hrs	2
Low Temperature storage	Endurance test applying the low storage temperature for a long time.	-30°C 200hrs	1,2
High Temperature Operation	Endurance test applying the electric stress (Voltage & Current) and the thermal stress to the element for a long time.	70°C 200hrs	—
Low Temperature Operation	Endurance test applying the electric stress under low temperature for a long time.	-20°C 200hrs	1
High Temperature/ Humidity Operation	The module should be allowed to stand at 60 °C, 90%RH max	60°C, 90%RH 96hrs	1,2
Thermal shock resistance	<p>The sample should be allowed stand the following 10 cycles of operation</p> <p style="text-align: center;">-20°C 25°C 70°C</p>  <p style="text-align: center;">30min 5min 30min 1 cycle</p>	-20°C /70°C 10 cycles	—
Vibration test	Endurance test applying the vibration during transportation and using.	Total fixed amplitude : 1.5mm Vibration Frequency : 10~55Hz One cycle 60 seconds to 3 directions of X,Y,Z for Each 15 minutes	3
Static electricity test	Endurance test applying the electric stress to the terminal.	VS=±600V(contact), ±800v(air), RS=330Ω CS=150pF 10 times	—

Note1: No dew condensation to be observed.

Note2: The function test shall be conducted after 4 hours storage at the normal Temperature and humidity after remove from the test chamber.

Note3: The packing have to including into the vibration testing.

10. Contour Drawing

PIN DESCRIPTION

NO.	SYMBOL
1	VLED-
2	VLED+
3	IM0
4	IM1
5	IM2
6	RESET
7	NC
8	NC
9	NC
10	NC
11	NC
12	NC
13-27	DB15-1
28	DB0(SPI_SDA)
29	NC
30	RD
31	WR
32	D/C(SPI_SCL)
33	CS(SPI_CS)
34	IOVCC
35	VCI
36	GND
37-40	NC

IM2	IM1	IM0	MPU Interface	GRAM
1	0	1	8080 MCU 16-bit bus	D[15:0]
1	0	0	8080 MCU 8-bit bus	D[7:0]
0	—	—	3-Line SPI	(D0 : SDA) (D/C : SCL) (SPL_CS)

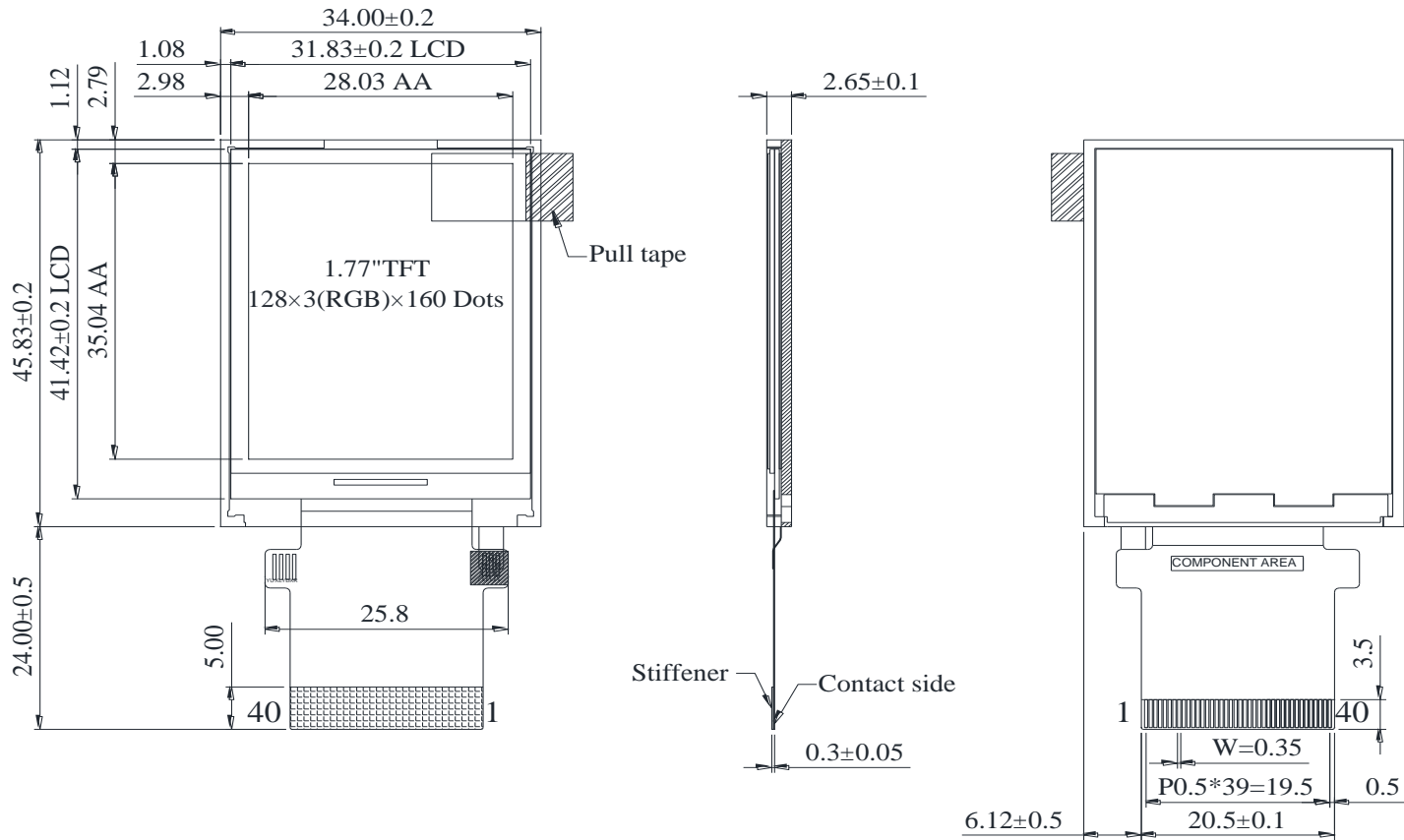

The non-specified tolerance of dimension is ±0.3 mm .



1、Panel Specification :

- 1. Panel Type : Pass NG , _____
- 2. View Direction : Pass NG , _____
- 3. Numbers of Dots : Pass NG , _____
- 4. View Area : Pass NG , _____
- 5. Active Area : Pass NG , _____
- 6. Operating Temperature : Pass NG , _____
- 7. Storage Temperature : Pass NG , _____
- 8. Others : _____

2、Mechanical Specification :

- 1. PCB Size : Pass NG , _____
- 2. Frame Size : Pass NG , _____
- 3. Material of Frame : Pass NG , _____
- 4. Connector Position : Pass NG , _____
- 5. Fix Hole Position : Pass NG , _____
- 6. Backlight Position : Pass NG , _____
- 7. Thickness of PCB : Pass NG , _____
- 8. Height of Frame to PCB : Pass NG , _____
- 9. Height of Module : Pass NG , _____
- 10. Others : Pass NG , _____

3、Relative Hole Size :

- 1. Pitch of Connector : Pass NG , _____
- 2. Hole size of Connector : Pass NG , _____
- 3. Mounting Hole size : Pass NG , _____
- 4. Mounting Hole Type : Pass NG , _____
- 5. Others : Pass NG , _____

4、Backlight Specification :

- 1. B/L Type : Pass NG , _____
- 2. B/L Color : Pass NG , _____
- 3. B/L Driving Voltage (Reference for LED Type) : Pass NG , _____
- 4. B/L Driving Current : Pass NG , _____
- 5. Brightness of B/L : Pass NG , _____
- 6. B/L Solder Method : Pass NG , _____
- 7. Others : Pass NG , _____

>> **Go to page 2** <<



Winstar Module Number : _____

Page: 2

5、Electronic Characteristics of Module :

- | | | |
|------------------------------|-------------------------------|-------------------------------------|
| 1. Input Voltage : | <input type="checkbox"/> Pass | <input type="checkbox"/> NG , _____ |
| 2. Supply Current : | <input type="checkbox"/> Pass | <input type="checkbox"/> NG , _____ |
| 3. Driving Voltage for LCD : | <input type="checkbox"/> Pass | <input type="checkbox"/> NG , _____ |
| 4. Contrast for LCD : | <input type="checkbox"/> Pass | <input type="checkbox"/> NG , _____ |
| 5. B/L Driving Method : | <input type="checkbox"/> Pass | <input type="checkbox"/> NG , _____ |
| 6. Negative Voltage Output : | <input type="checkbox"/> Pass | <input type="checkbox"/> NG , _____ |
| 7. Interface Function : | <input type="checkbox"/> Pass | <input type="checkbox"/> NG , _____ |
| 8. LCD Uniformity : | <input type="checkbox"/> Pass | <input type="checkbox"/> NG , _____ |
| 9. ESD test : | <input type="checkbox"/> Pass | <input type="checkbox"/> NG , _____ |
| 10. Others : | <input type="checkbox"/> Pass | <input type="checkbox"/> NG , _____ |

6、Summary :

Sales signature : _____

Customer Signature : _____

Date : / / _____