

SMJR-N-2-XX - NanoDriver

16W & 24W 230V LED Driver

Nano Driver

SMJR-N-2-XX

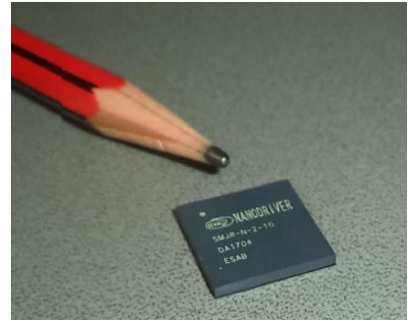

Product Brief

Description

The Seoul Semiconductor NanoDriver range of Phase cut drivers are ideal for downlight, spot and track light as well as wall sconce and flush mount fixtures. Based on an incredibly small package, this is ideal for very small custom driver design or for creating AC LED Modules. The NanoDriver has very low ripple current, enabling easy California Title 24 flicker compliance.

Features and Benefits

- Very small size 0.53" x 0.53" x 0.05"
- Low flicker for Title 24 compliance
- AC Phase cut dimming or analog dimming
- Over temperature protection
- Ultra Low Inrush current
- >0.9 Power Factor
- 5V 20mA Auxiliary Bias Supply

Product Selection

Part No.	Vin [Vac]	P [W]		Remark
		Min.	Max.	
SMJR-N-2-16	230	10	16	1100-1800 Lumens Typ
SMJR-N-2-24	230	18	24	2000-2700 Lumens Typ

Typical Circuit diagram

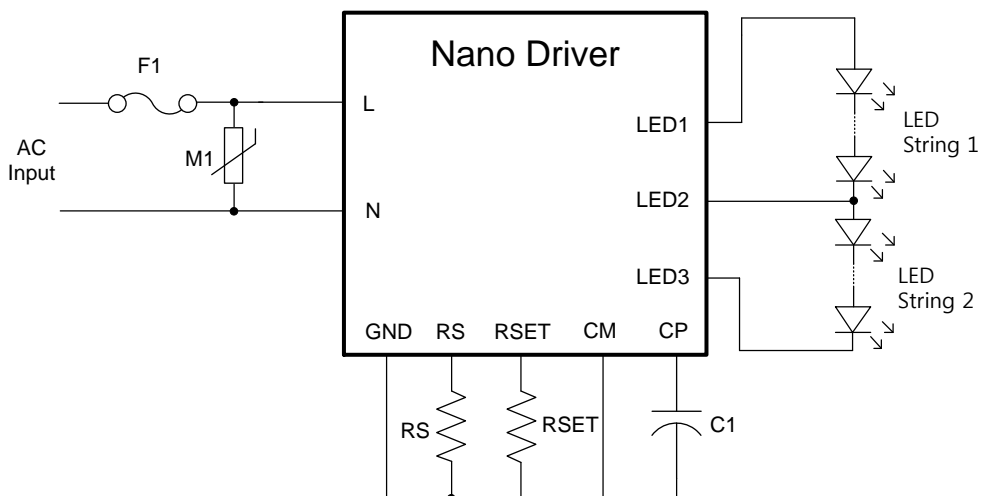

Contents

Maximum Ratings	3
Block Diagram	4
Functional Description	6
Specification	7
Electrical Characteristic	8
Power Dissipation	10
Thermal	11
Typical Application Schematic	12
Component Selection	14
Analog Dimming	19
Phase Cut Dimmer Compatibility	21
Mechanical	22
Circuit Layout	23
Reflow Soldering Profile	24
Marking	25
Emitter Tape & Reel Packaging	26
Packaging	27
Precautions	29

Performance Characteristics

Absolute Maximum Ratings, $T_a = 25^\circ\text{C}$

Parameter	Symbol	Unit	Lower Limit	Upper Limit
L,N, LED1, LED2, BLDP, BLDN to GND	-	V	-0.3	450
ADIM, RSET, VAUX, VPS, ISN, RSET,RS1, RS2 to GND	-	V	-0.3	6.5
Continuous Power Dissipation (TA=25°C) ²⁾	P	W	-	4.33
Operating Case Temperature	T_c	°C	-40	120
Operating Ambient Temperature	T_a	°C	-40	70
Storage Ambient Temperature	T_{stg}	°C	-40	120
Maximum Junction Temperature	T_j	°C	-	150
ESD (HBM) ¹⁾	-	kV	-	1.5

Notes :

Stress beyond those listed Absolute Maximum Ratings may cause permanent damage to the device. These are stress ratings only and functional operation of the device at these or any other condition beyond those indicated in the following operational sections of the specifications is not implied. Exposure to absolute maximum rating condition(s) for extended periods may affect device reliability.

- 1) Human Body Model (HBM) per JESD22-A114 for all pins.
- 2) Power dissipation is dependent on exact circuit configuration, including input voltage, output power, auxiliary power consumption etc. Expected Power dissipation is provided in detailed power dissipation curves below.

Block Diagram

SMJR-N-2-16 Upto 16W with internal bleeder.

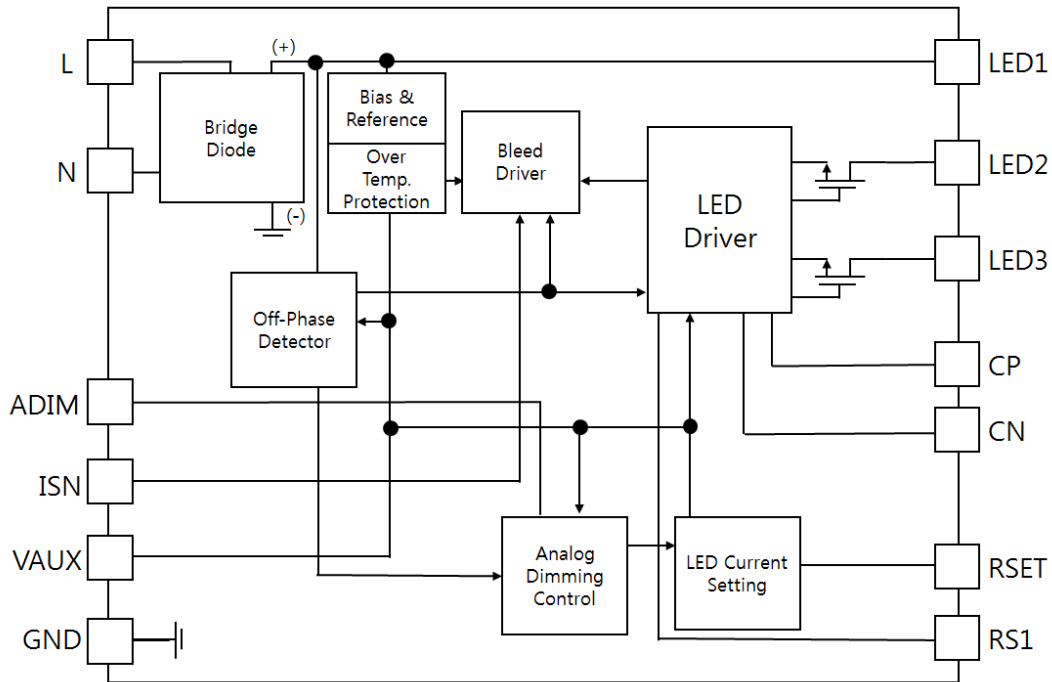

Pin	Name	Description
1	L	AC Input Live
2	N	AC Input Neutral
3	ADIM	Analog Dimming (0.45V ~ 3V)
4	ISN	Ground
5	VAUX	Auxiliary Power Supply Output(5V 20mA)
6	GND	Voltage Output (-)
7	RS1	L1 Current Setting
8	RSET	Total Current Setting
9	CN	Capacitor (-)
10	CP	Capacitor (+)
11	LED3	LED (-)
12	LED2	LED middle
13	LED1	LED (+)

Block Diagram

SMJR-N-2-24 16-24W with external bleeder resistor.

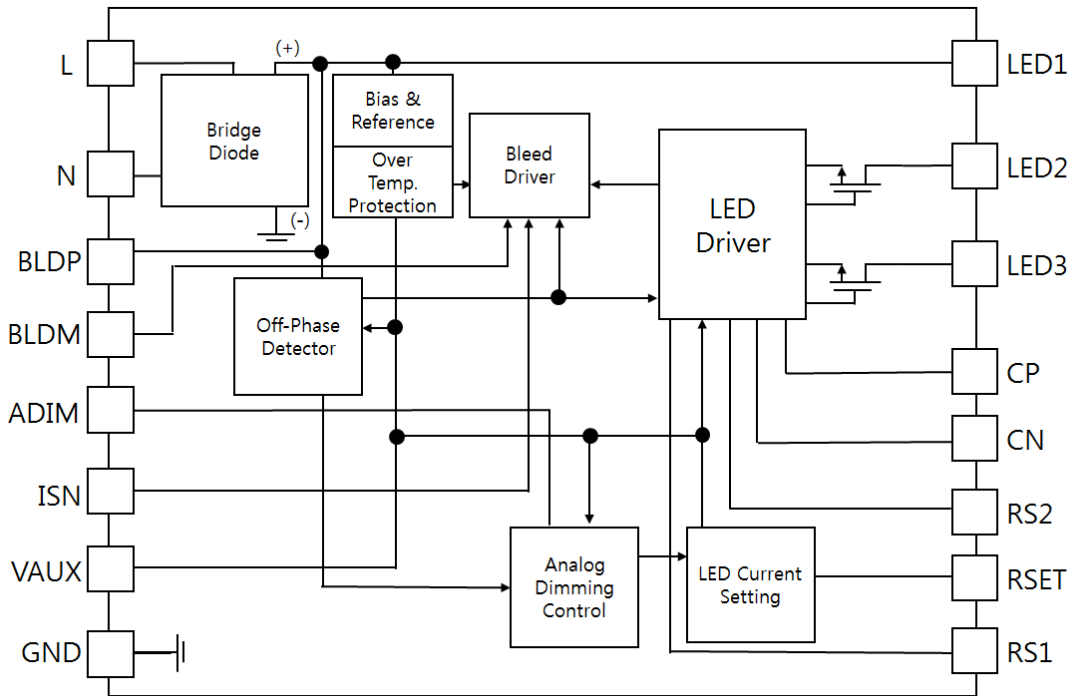

Pin	Name	Description
1	L	AC Input Live
2	N	AC Input Neutral
3	BLDP	Bleed Resistor
4	BLDM	Bleed Resistor
5	ADIM	Analog Dimming (0.45V ~ 3V)
6	ISN	Ground
7	VAUX	Auxiliary Power Supply Output(5V 20mA)
8	GND	Voltage Output (-)
9	RS1	L1 Current Setting
10	RSET	Total Current Setting
11	RS2	L1 Current Setting
12	CN	Capacitor (-)
13	CP	Capacitor (+)
14	LED3	LED (-)
15	LED2	LED middle
16	LED1	LED (+)

Device Functional Description

Topology and Fundamental Operation

The NanoDriver uses a patented Seoul Semiconductor AC Topology using low frequency current steering without the use of magnetic components. During the peaks of the sinewave energy is stored in an electrolytic capacitor. The stored energy is used to power the LEDs during the trough between the peaks to provide an equivalent dc flux to provide very lower measured ripple. The NanoDriver supports both leading Edge and Trailing edge dimmer compatibility or can be configured for analog dimming such as 0-10V dimming.

Bleeding Function

The NanoDriver includes a bleeding functions which enables operation with multiple dimmers. In Analog Dimming Mode, bleeding functions are disabled, and bleeding functions are enabled in TRIAC dimmer mode only. The main functions provide the dimmers with sufficient current to maintain the minimum holding current for various Triacs and to simulate filament turn on current for some active smart dimmers in common use. A list of tested dimmers is provided below.

Thermal Protection

The NanoDriver includes a thermal shutdown function. This protection protects the NanoDriver from overheating caused by excessive power dissipation. An internal temperature sensor continuously monitors the junction temperature. If junction temperature exceeds about 160°C, the LED current will be reduced to the half of the total current.

RSET Open Protection

When the R_{SET} voltage exceeds R_{SET} open detection voltage V_{RSETP} (typ. 2V), all LED drivers are disabled. And all LED drivers will resume operation when the R_{SET} voltage falls below V_{RSETN} (typ. 1.5V). There is a typical 0.5V hysteresis for reliable operation.

VAUX Short Protection

The NanoDriver has the V_{AUX} short circuit protection. When the V_{AUX} voltage falls below the V_{CC} Foldback ON voltage V_{FBON} (typ. 0.5V), the LED current is reduced abruptly and V_{AUX} current is limited by 4mA. If the abnormal condition is removed and the V_{CC} voltage rises above V_{AUX} Foldback OFF voltage V_{FBOFF} (Typ. 1.0V), the LED current and V_{CC} current is re-established. There is a typical 0.5V hysteresis for reliable operation.

Specification

Specification, Ta = 25°C

AC Input Voltage	AC 230V	
Model	SMJR-N-2-16	SMJR-N-2-24
MAXIMUM RATED AVERAGE CURRENT	85mA	127mA
OPERATING VOLTAGE	LED String 1 =88V LED String 2 =106V	
CURRENT ACCURACY	±5%	
FLICKER	Less Than 10%	
STARTUP TIME	<300ms	
FREQUENCY RANGE	50~60Hz	
POWER FACTOR(Typ.)	PF > 0.9	
INRUSH CURRENT(max.)	<30mA	
LINE REGULATION	±10% at AC ±10%	

Performance Characteristics

Electrical Characteristics, $V_{VP} = 50V$, $T_a = 25^\circ C$

Parameter	Symbol	Condition	Value			Unit
			Min.	Typ.	Max.	
GENERAL						
Operating Range	V_{S_VP}		15		400	V
VDD Turn On Threshold Voltage ¹⁾	V_{VDD_ON}	V_{VCC} rising	3.0	3.6	4.4	V
VDD Hysteresis Voltage ¹⁾	V_{VDD_HYS}	V_{VDD_OFF} $=V_{VDD_ON} - V_{VDD_HYS}$	-	0.4	-	V
VP Operating Current	I_{OPR}	$V_p=50V$	-	900	1300	uA
VAUX Auxiliary Output	V_{VCC}	$I_{LOAD}=0mA$	5.2	6.0	6.2	V
	V_{VCC2}	$I_{LOAD}=10mA$		5.4		V
	V_{VCC3}	$I_{LOAD}=20mA$		5.0		V
RSET Current	I_{RSET}	At normal condition	148	155	162	uA
RSET Current at Maximum Scaling	I_{RSCL}	At maximum scaling	5	15	30	uA
PROTECTIONS						
Thermal Shutdown Temperature ²⁾	TSD	Temperature latch off Recycle power to recover		160		°C
RSET Open Detection Positive Voltage	V_{RSETP}	VRSET rising	1.7	2.0	2.3	V
RSET Open Detection Hysteresis Voltage	V_{RSET_HYS}	$V_{RSETN}=V_{RSETP}-V_{RSET_HYS}$	-	0.5	-	V
VAUX Foldback On Voltage	V_{FBON}	V_{VCC} falling	0.2	0.5	0.7	V
VAUX Foldback Hysteresis Voltage	V_{FB_HYS}	$V_{FBOFF}=V_{FBON}+V_{FB_HYS}$	-	0.5	-	V
VAUX Foldback Current	I_{FB}		3	4	5.5	mA

Performance Characteristics

Electrical Characteristics, $V_{VP} = 50V$, $T_a = 25^\circ C$

Parameter	Symbol	Condition	Value			Unit
			Min.	Typ.	Max.	
ANALOG DIMMING CONTROLLER						
ADIM Off Voltage	V_{ADIM_OFF}	RSET=2k Ω , ADIM falling	310	400	470	mV
ADIM Off Hysteresis Voltage	V_{ADIM_HYS}	$A_{DIM_ON} = V_{ADIM_OFF} + V_{ADIM_HYS}$	-	050	-	mV
ADIM Clamp Voltage Range	V_{ADIM_CL}	ADIM sweep	-	3.0	-	V
BLEEDING CURRENT DRIVER						
Week Bleeding Current	I_{BLD_WK}		60	73	80	mA
Startup Bleeding Current	I_{BLD_SS}	Bleeding current at startup	30	32	40	mA
Maximum Bleeding Current	I_{BLD_MAX}		40	45	50	mA
SCALING						
Scaling Start Angle ²⁾	D_{START}		-	120	-	Deg.
Scaling End Angle ²⁾	D_{END}		-	90	-	Deg.

Notes :

$V_{VP} = 50V$, $T_A = -40^\circ C \sim 85^\circ C$). Typical values are at $T_A = 25^\circ C$, unless otherwise specified.

¹⁾ Specifications over the T_A range are assured by design, characterized and correlated with process control.

1) The VDD is internal power supply for internal block.

2) Guaranteed by design, characterization and correlation with process controls. Not fully tested in production.

Characteristics Graph

IC Power Dissipation

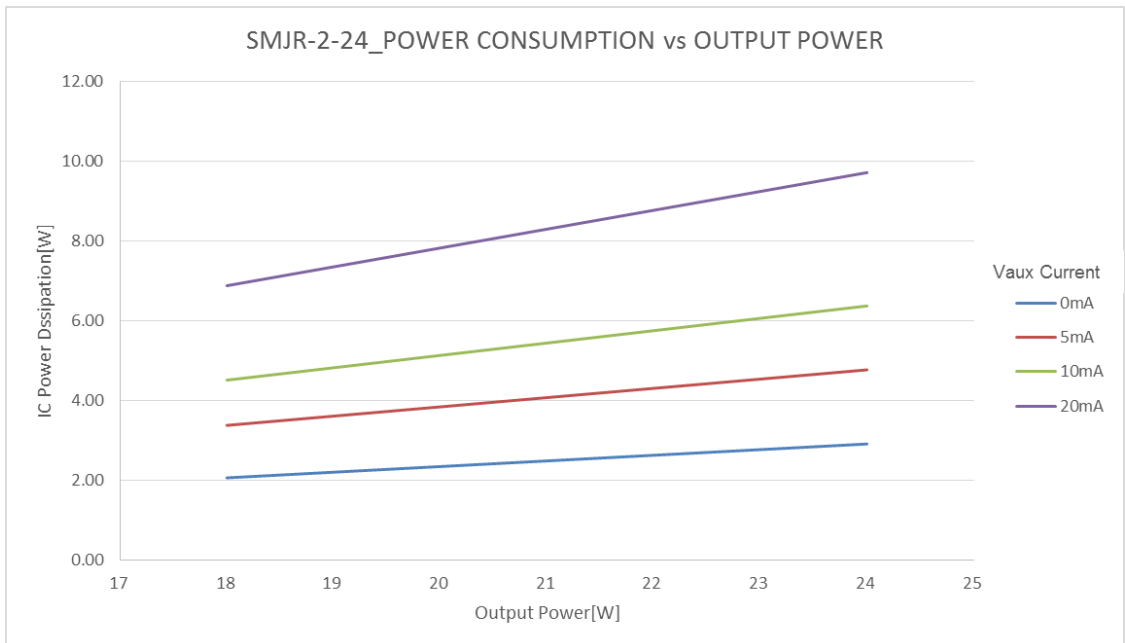
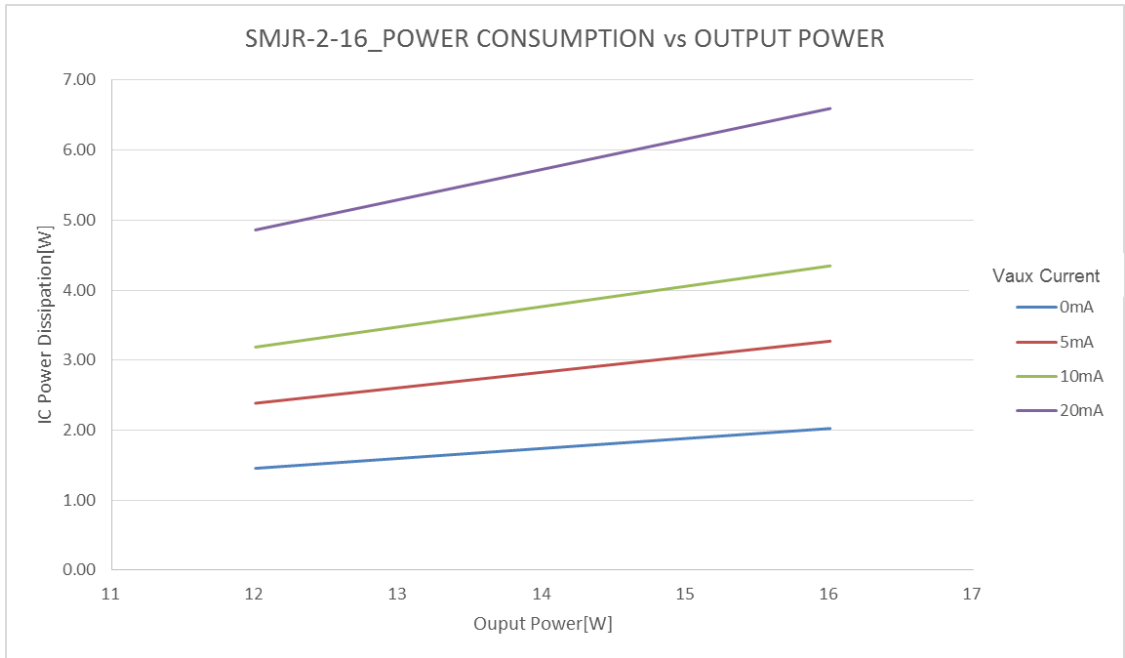

Thermal Resistance

Thermal Resistance

Parameter	Symbol	Value	Unit
Thermal Resistance Junction to Ambient ^{1), 2), 3)}	Θ_{JA}	28.9	°C/W
Thermal Resistance Junction to Case, Top ^{1), 2), 4)}	Θ_{Jc}	14.8	°C/W

Notes :

1) $T_A = 25\text{ °C}$

2) Measured in still air-free convection condition (conforms to EIA/JESD51-2) on high effective thermal conductivity JESD51-7 test board.

$$3) \Theta_{JA} = (T_{J,max} - T_A) / P_{D,max}$$

where, $T_{J,max}$, T_A , Θ_{JA} and $P_{D,max}$ are maximum junction temperature, ambient temperature, junction-to-ambient thermal resistance and maximum power dissipation respectively. This conforms to JESD51-12.

$$4) \Theta_{JcX} = (T_J - T_c) / P$$

where, T_J , T_c , Θ_{JcX} and P are junction temperature, case temperature, junction-to-case thermal resistance and the part of the chip power that flows from junction to the “x” case surface respectively.

And the “x” indicates the case surface where T_c is measured and through which the heat is forced to flow during the Θ_{JcX} measurement, “TOP” for the top surface or “BOT” for the bottom surface. This conforms to JESD51-12.

Operating Circuit

Upto 16W Phase Cut Dimming

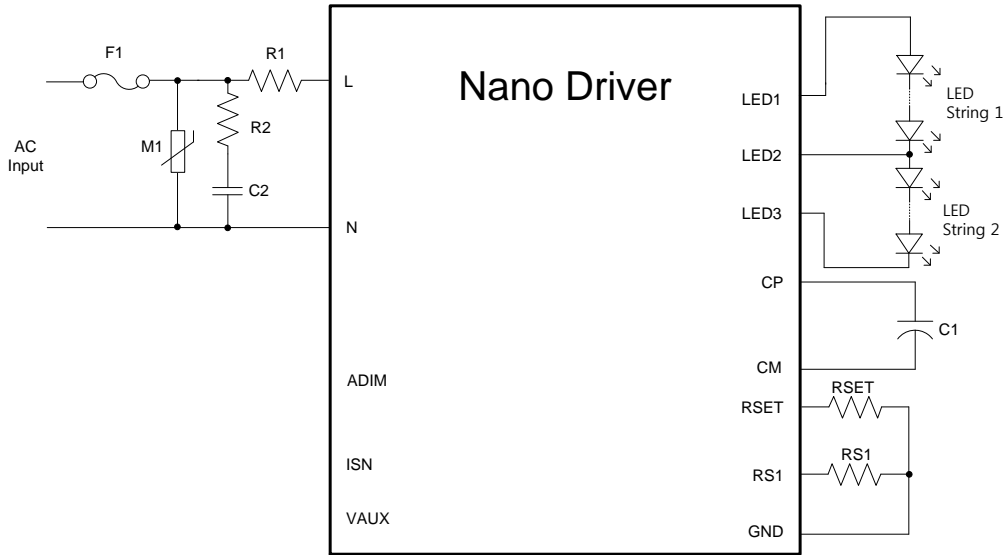

Notes :

- 1) C2 and R2 are optional. It required for obtaining the highest triac dimming.

Upto16W 0-10V Dimming

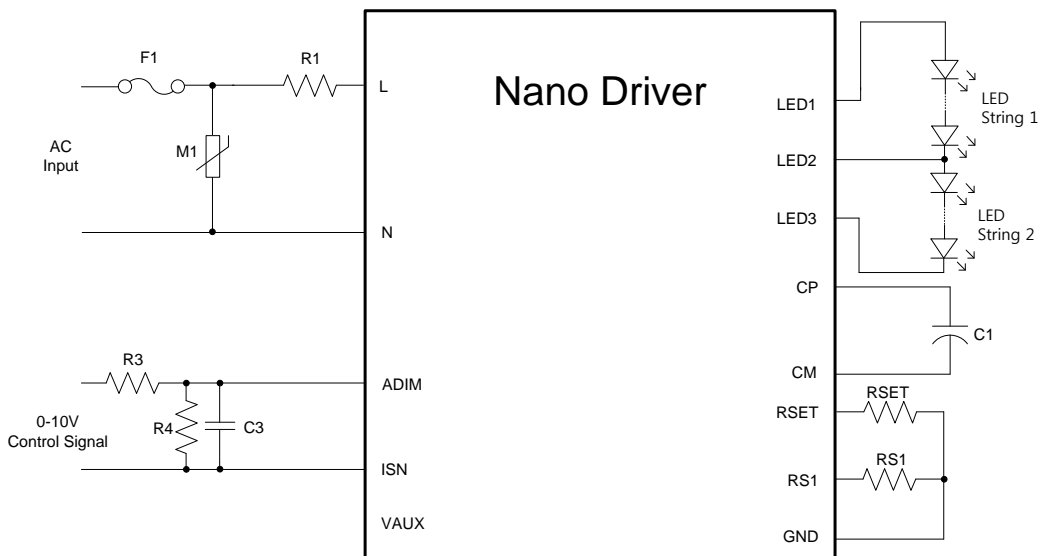

Notes :

- 1) The NanoDriver is a non-isolated topology and the 0-10V signal needs to be isolated. VAUX is a bias supply that may be used to assist in isolating the source.

Operating Circuit

16-24W Phase Cut Dimming

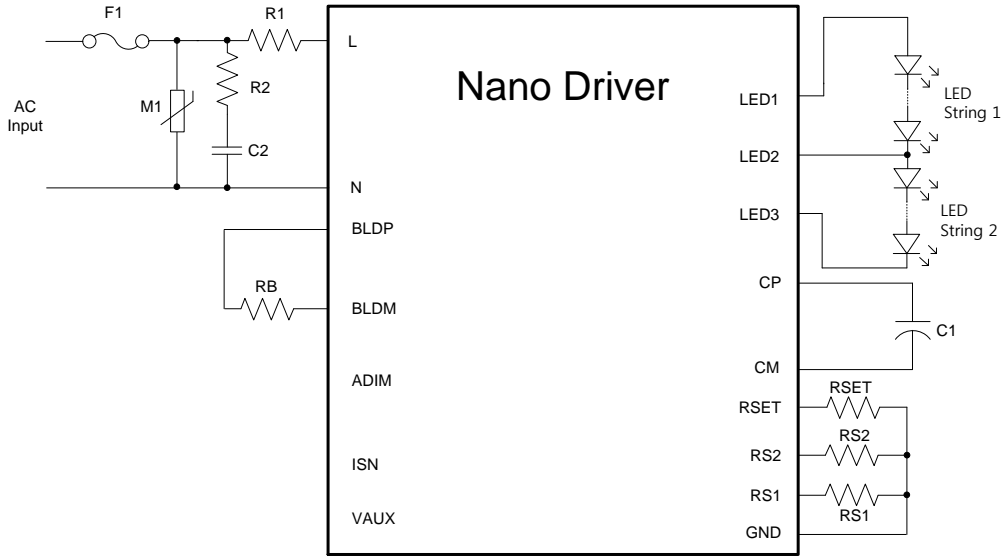

Notes :

- 1) C2 and R2 are optional. It required for obtaining the highest triac dimming.

16-24W 0-10V Dimming

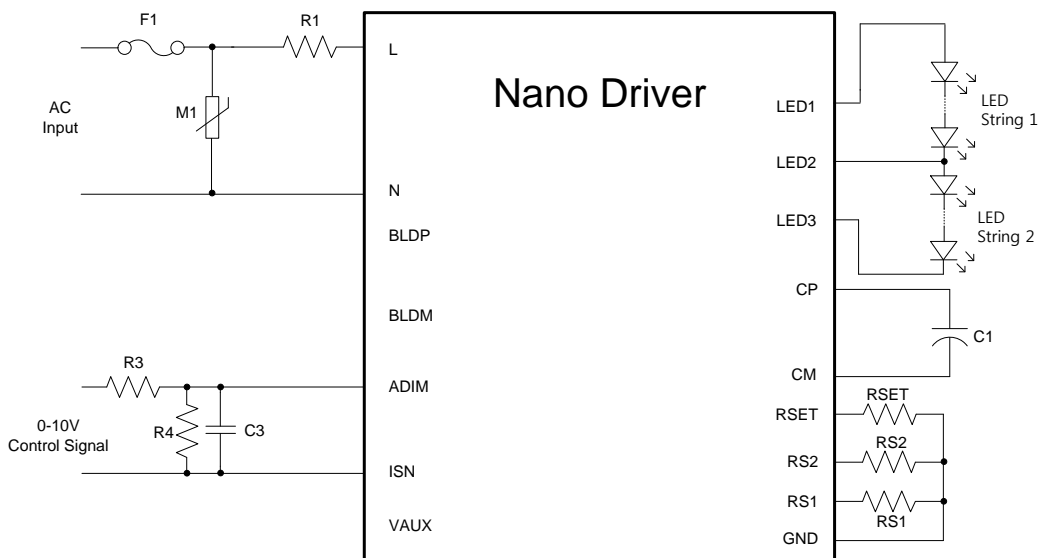

Notes :

- 1) The NanoDriver is a non-isolated topology and the 0-10V signal needs to be isolated. VAUX is a bias supply that may be used to assist in isolating the source.

Operating Circuit

Component Selection - Typical Values

Power [W]	Io [mA]	C1	R1	RS1	RS2	RSET
10	48	350V 10uF 2 parallel	47Ω, 1W (5%)	4.3Ω, 0.25W (1%)	-	2.6kΩ, 0.25W (1%)
12	58	350V 10uF 2 parallel	33Ω, 1W (5%)	4.3Ω, 0.25W (1%)	-	3.1kΩ, 0.25W (1%)
14	68	350V 10uF 2 parallel	10Ω, 1W (5%)	4.3Ω, 0.25W (1%)	-	3.66kΩ, 0.25W (1%)
16	77	350V 10uF 2 parallel	10Ω, 1W (5%)	4.3Ω, 0.25W (1%)	-	4.17kΩ, 0.25W (1%)
18	87	350V 10uF 3 parallel	10Ω, 1W (5%)	4.3Ω, 0.25W (1%)	4.3Ω, 0.25W (1%)	1.22kΩ, 0.25W (1%)
20	97	350V 10uF 3 parallel	10Ω, 1W (5%)	4.3Ω, 0.25W (1%)	4.3Ω, 0.25W (1%)	1.35kΩ, 0.25W (1%)
22	106	350V 10uF 3 parallel	10Ω, 1W (5%)	4.3Ω, 0.25W (1%)	4.3Ω, 0.25W (1%)	1.49kΩ, 0.25W (1%)
24	116	350V 10uF 3 parallel	10Ω, 1W (5%)	4.3Ω, 0.25W (1%)	4.3Ω, 0.25W (1%)	1.63kΩ, 0.25W (1%)

LEDs Selection and Configuration

The NanoDriver output is actually a high voltage waveform in 2 strings. The wave form is using Seoul Semiconductor patented AC waveform with a net light flux that has very low measurable Flicker. For 230Vac input the device is optimized with a String 1 88V and String 2 106V. The converter current is actually divided between the 2 strings with String 1 current measuring approximately 115% of the converter running current and String 2 75% of the converter running current.

The NanoDriver can be used with any LED however the best performance and cost optimization is using Seoul Semiconductor MJT LEDs. For the lowest cost solution the recommended LED to us is the MJT 3528 series and for the smallest LES(Light Emitting surface) for spot lights or narrow beam solution use the ICOP Y11 LEDs. The Following Table provides Part numbers and recommended schematic for connecting the LEDs for each solution:

Operating Circuit

Small LES LED Connection

LED	WICOP Y11 9V Part Number SZ8-Y11-WN-C8-C-ZZ*							
CRI	80							
CCT	4000K							
Power[W]	10	12	14	16	18	20	22	24
Nano Driver	SMJR-N-1-16				SMJR-N-1-24			
Target lumen	1130	1350	1580	1800	2030	2260	2480	2710
LED Qty. on 1 step	10	10	10	10	10	10	10	10
LED Qty. on 2 step	12	12	12	12	12	12	12	12
Total[ea]	22	22	26	33	37	44	48	55
Schematic	Fig. 1		Fig. 2		Fig. 3		Fig. 4	
Current[mA]	48	58	68	77	87	97	106	116
RS1[Ω]	4.3	4.3	4.3	4.3	4.3	4.3	4.3	4.3
RS2[Ω]					4.3	4.3	4.3	4.3
RSET[kΩ]	2.6	3.1	3.66	4.17	1.22	1.35	1.49	1.63

*ZZ is the color temperature eg 2k7=2700CCT, 4k =4000CCT

Lowest Cost LED Connection

LED	MJT3528 9V Part Number SAW8A32E-ZZ*							
CRI	80							
CCT	3000K							
Power[W]	10	12	14	16	18	20	22	24
Nano Driver	SMJR-N-1-12				SMJR-N-1-24			
Target lumen	1150	1380	1610	1840	2070	2300	2530	2760
LED Qty. on 1 step	10	10	10	10	10	10	10	10
LED Qty. on 2 step	12	12	12	12	12	12	12	12
Total[ea]	22	22	26	33	37	44	48	55
Schematic	Fig. 1		Fig. 2		Fig. 3		Fig. 4	
Current[mA]	48	58	68	77	87	97	106	116
RS1[Ω]	4.3	4.3	4.3	4.3	4.3	4.3	4.3	4.3
RS2[Ω]					4.3	4.3	4.3	4.3
RSET[kΩ]	2.6	3.1	3.66	4.17	1.22	1.35	1.49	1.63

*ZZ is the color temperature eg 2k7=2700CCT, 4k =4000CCT

To adjust the current down for a specific Lumen Target the current can be reduced by changing the value of RSET

SMJR-N-2-16

$$R_{set} = \frac{\text{Current[A]}}{0.0185}$$

SMJR-N-2-24

$$R_{set} = \frac{\text{Current[A]}}{0.075}$$

Operating Circuit

Fig 1

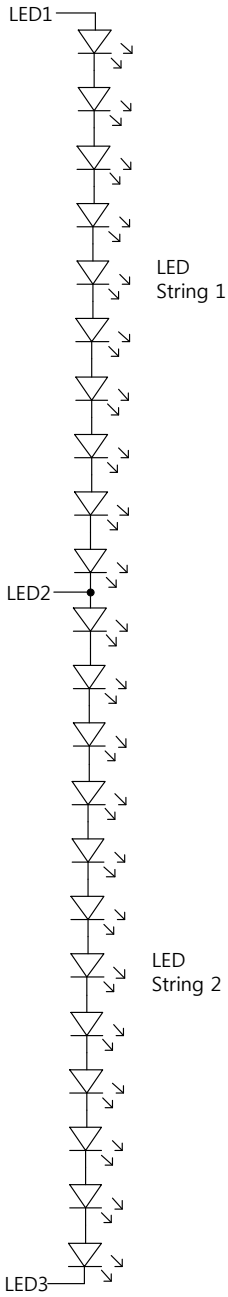

Fig 2

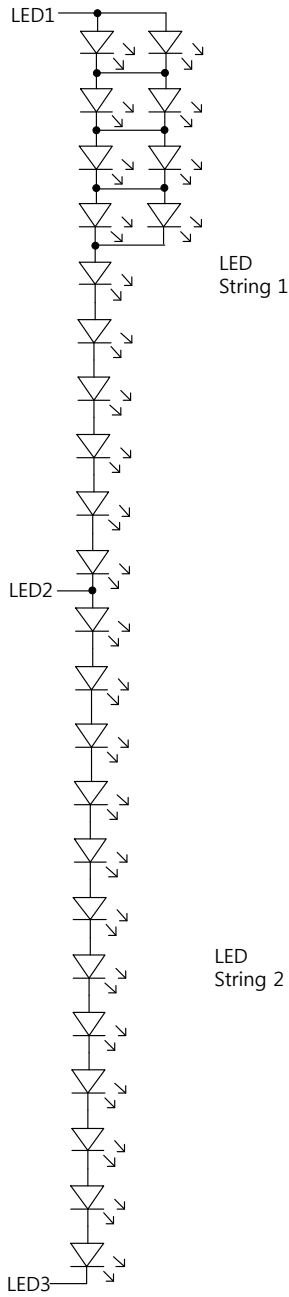

Fig 3

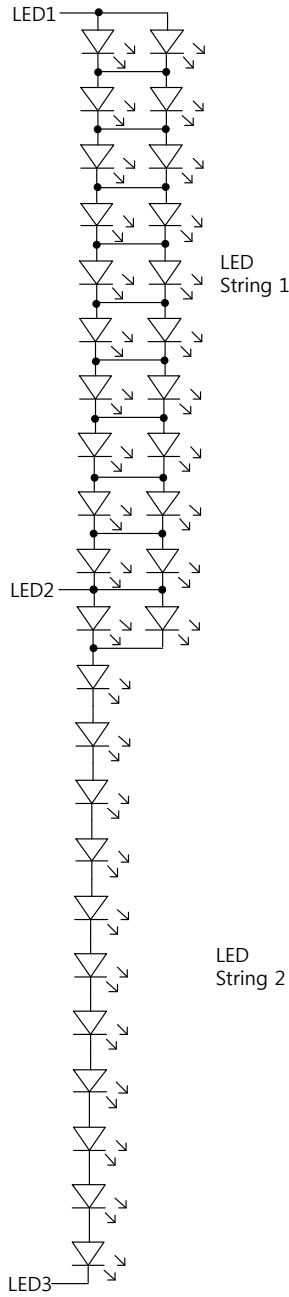
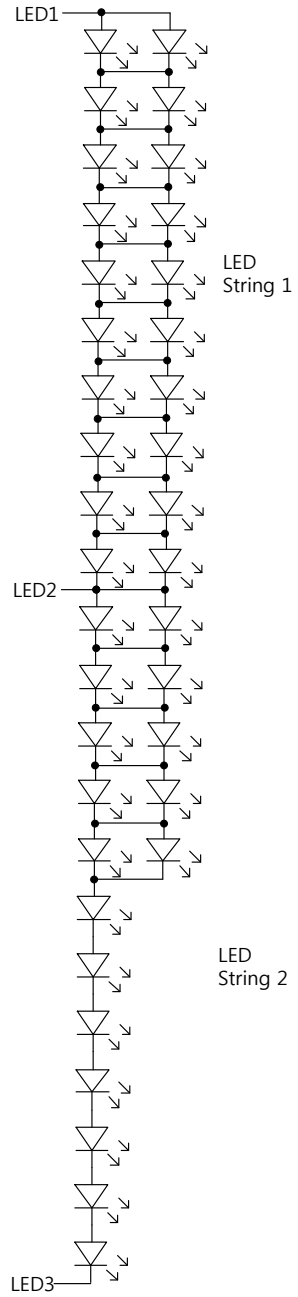

Fig 4



Operating Circuit

Fig 5

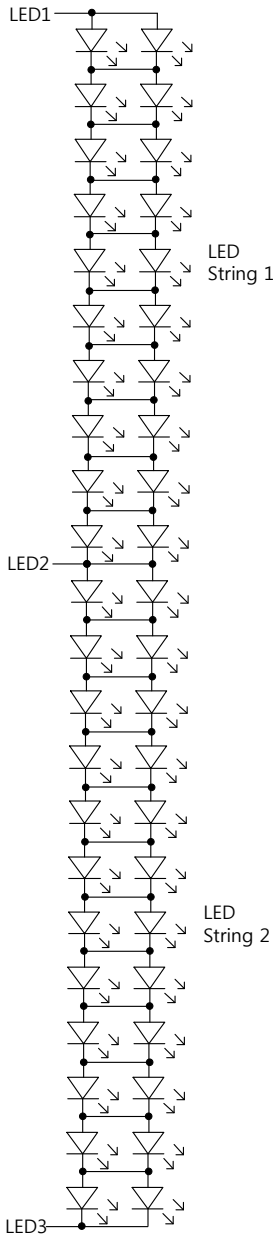

Fig 6

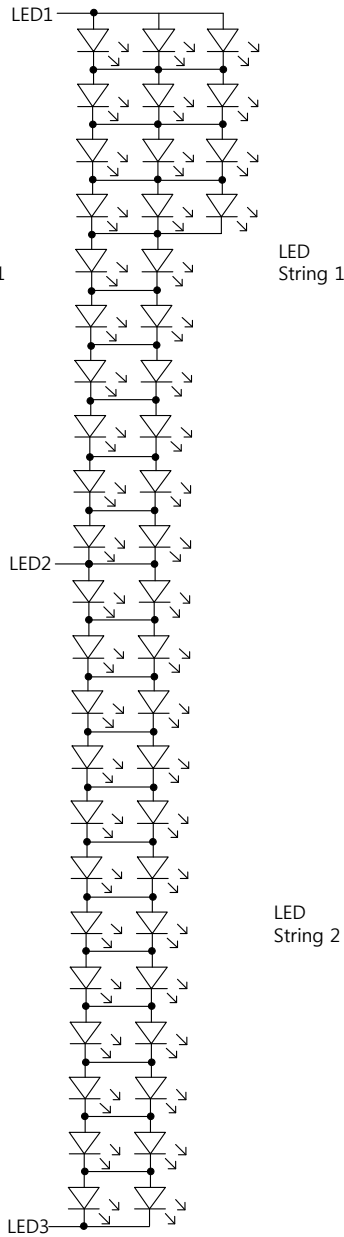
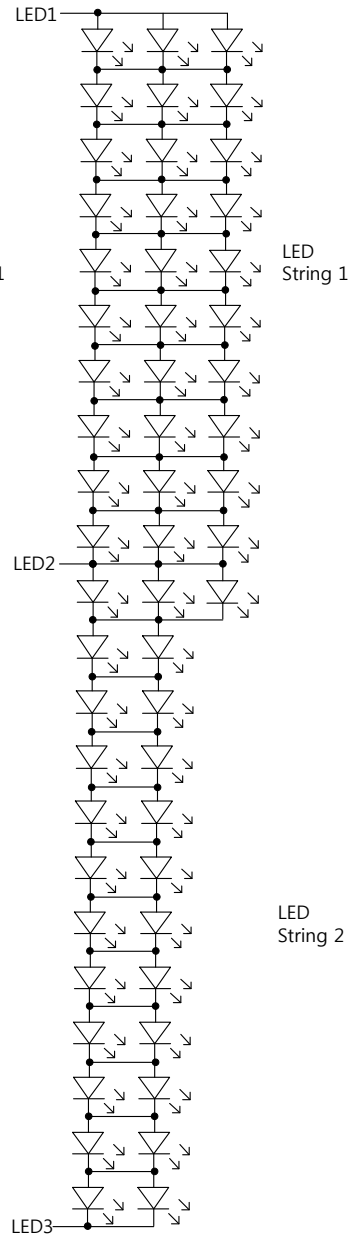

Fig 7



Operating Circuit

Component Selection

Fuse F1

Slow-Blow type 250V 1A $I^2T=2.85$

Surge Protection MV1

$V_{rms} = 250V$, $I_{surge, max} = 400A$
recommended TDK / CU3225K250G or equivalent

Bleeder Resistor RB

The Bleeding Function is required for compatibility to various Phase Cut or Triac Dimmers. The is required to maintain minimum holding currents and turn-on characteristics. For Power below 16W the Bleeder function is internal to the device. Above 16W an external resistor is required for thermal reasons. For Output Power >16W, use 2 1.2k Ω 1W carbon film resistor in series.

Passive Bleeder R2, C2

The Bleeding Function is required for compatibility to various Phase Cut or Triac Dimmers. The is required to latching currents.

R2 value is recommended 680 Ω 2W carbon film and C2 is 275V 47nF X2 capacitor.

Flicker Capacitor C1

C1 is used to reduce the current ripple in the output LED strings. Any general purpose Aluminum Electrolytic capacitor may be used. Recommended value for <16W is 20 μ F and 30 μ F for >16W. Rating for 230V is recommended 350V and ripple current rating 1.3 times the current. Note that Aluminum Electrolytic capacitors do have a shelf life and wear out characteristic that causes the capacitance to decrease over time. This is accelerated with high temperature operation. Please consult with vendor for calculating life and recommendations to meet the expected product life. The value for Rset will need to change to achieve the same light output. Please contact the factory for recommendations.

EMI Resistor R1

This component is only required for Class B conducted EMI. It may be omitted if not required.

Operating Circuit

Analog Dimming

The LED brightness can be adjusted by applying DC voltage to ADIM Pin. When the ADIM DC voltage becomes over 3.0V, the LED brightness is clamped at their maximum flux. When ADIM DC voltage is decreased to 0.4V, LED current becomes off. The voltage has hysteresis to stop flicker and requires the voltage to be raised to 0.45V to turn it back on.

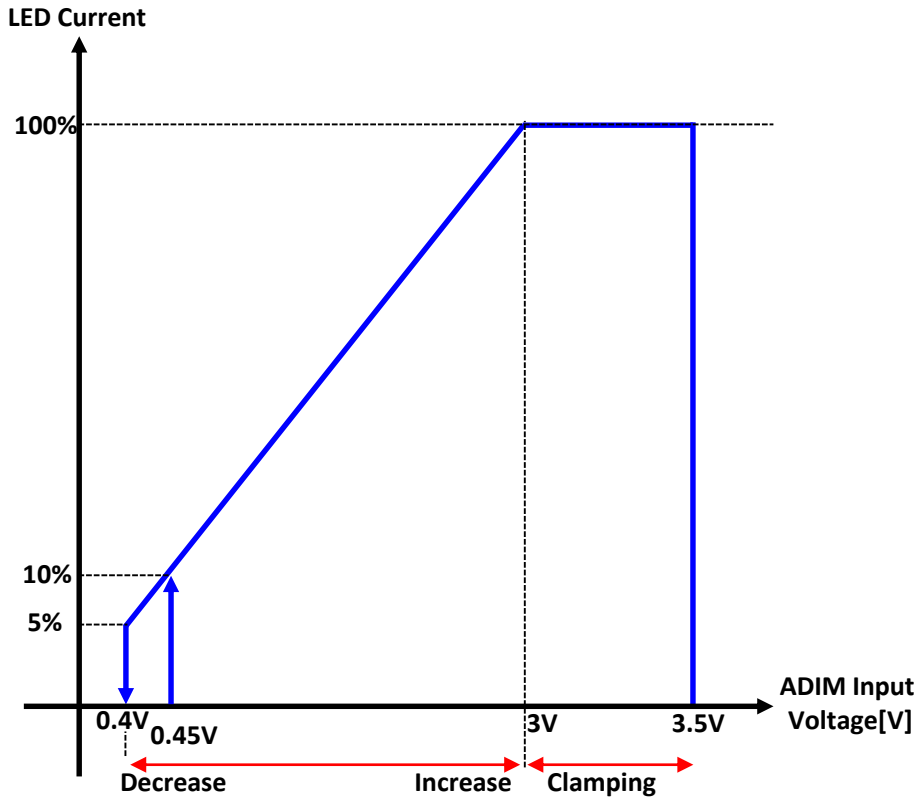

Operating Circuit

External Resistor Setting – For Example

The V_{ADIM} voltage is set using a resistive voltage divider from the V_{DIM_IN} to ADIM pin. The recommended R3 resistor at 10k Ω . Calculate the R4 resistor using the following equation.

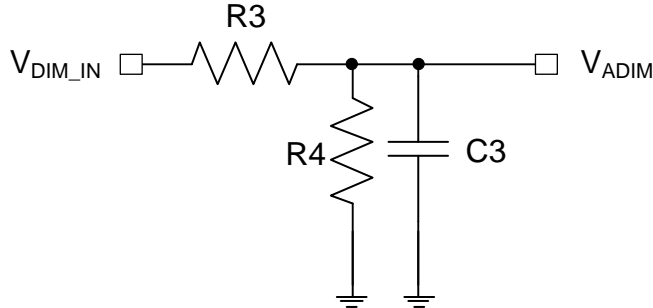

$$R4 = \frac{R3 \times V_{ADIM}}{V_{DIM_IN} - V_{ADIM}}$$

Assumptions for the purposes of this example, the following are given as the application requirements:

- V_{DIM_IN} : External dimming voltage signals (0V : Min, 10V : Max)
- R3 : 10k Ω (Recommended value^[1])
- V_{ADIM} : 3V (Constant value^[2])

$$R4 = \frac{R3 \times V_{ADIM}}{V_{DIM_IN} - V_{ADIM}} = \frac{10K\Omega \times 3V}{10V - 3V} = 4.3K\Omega$$

Notes :

- 1) Considering the power consumption of the IC, set the resistance value.
- 2) When the Adim Pin level is 3V, the LED Flux reaches the 100%.

Device Functional Description

Phase Cut Dimmer Compatibility

Brand	Model	Dimming type	Op. voltage[V]	Dim. Range[%]	Visible Flicker During Dimming			Uniform Dimming
					At Max Level	Min ~ Max	At Min Level	
IKEA	EED200BRS	Leading	230	5-99%	No	No	No	OK
	EED20PRS	Leading	230	5-99%	No	No	No	OK
SELECTRIC	SSL509	Leading	230	5-98%	No	No	No	OK
Merten	572599	Leading	230	5-98%	No	No	No	OK
Merten	MEG5133	Leading	230	5-96%	No	No	No	OK
Busch	2247	Leading	230	5-99%	No	No	No	OK
Busch	6513	Trailing	230	5-92%	No	No	No	OK
KOPP	8068	Leading	230	5-99%	No	No	No	OK
KOPP	8002	Trailing	230	5-93%	No	No	No	OK
GA	EFS700DA	Leading	230	5-98%	No	No	No	OK
GA	EFE700DA	Leading	230	5-98%	No	No	No	OK
GA	EF700DC	Trailing	230	5-92%	No	No	No	OK
EHMANN	LUMEO ECO	Leading	230	5-98%	No	No	No	OK
EHMANN	TAST-DIMMER ANSCHNITT	Leading	230	5-98%	No	No	No	OK
EHMANN	DIMMER T46	Trailing	230	5-88%	No	No	No	OK

Notes :

- 1) The list includes dimmers tested at time of publishing. This table will be updated from time to time as other dimmers are tested

Mechanical Dimensions

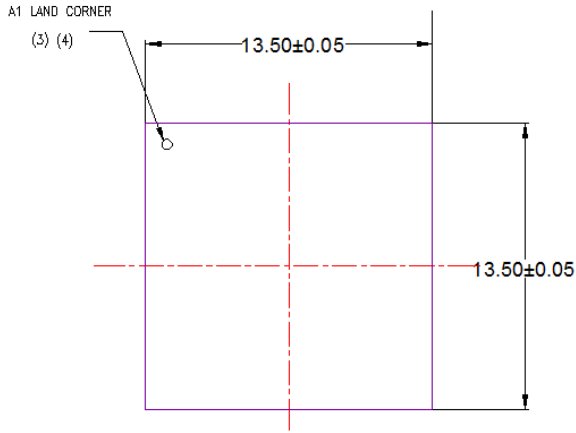

<TOP VIEW>

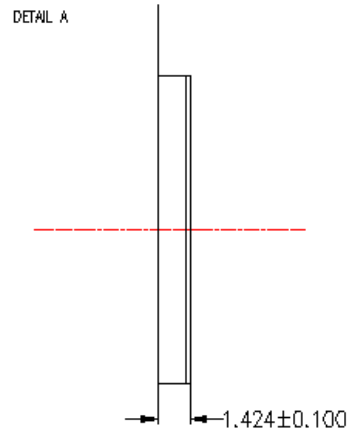

<SIDE VIEW>

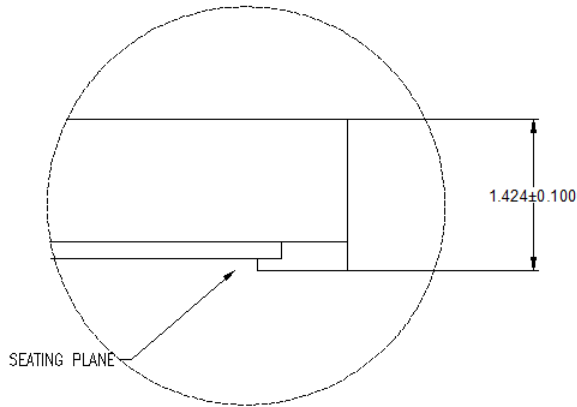

<DETAIL A (Rotated 90°)>

Notes :

- 1) All dimensions and tolerance conform to ASME Y14.5-2009
- 2) Terminal positions designation per JEP 95.
- 3) PIN 1 Identifier can be chamfer, INK mark, LASERED mark, Metallized.

Recommended Solder Pad

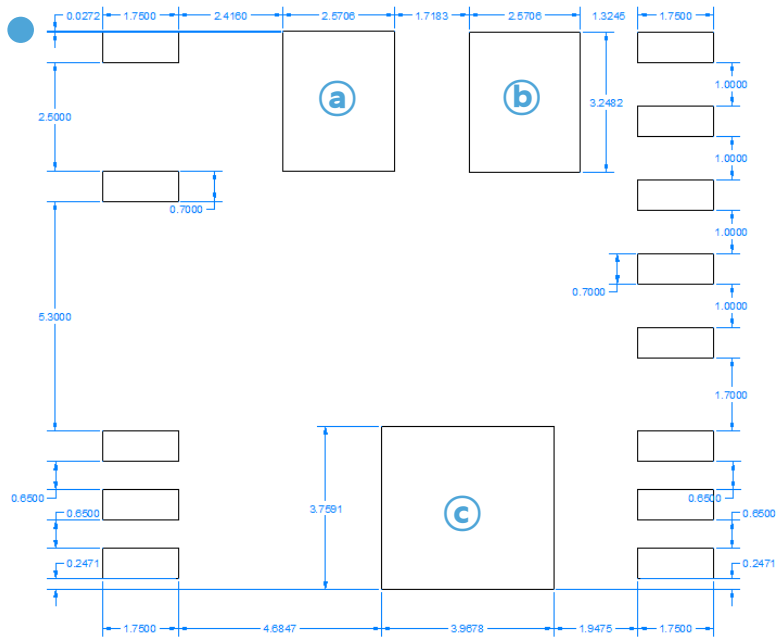

<SMJR-N-1-16>

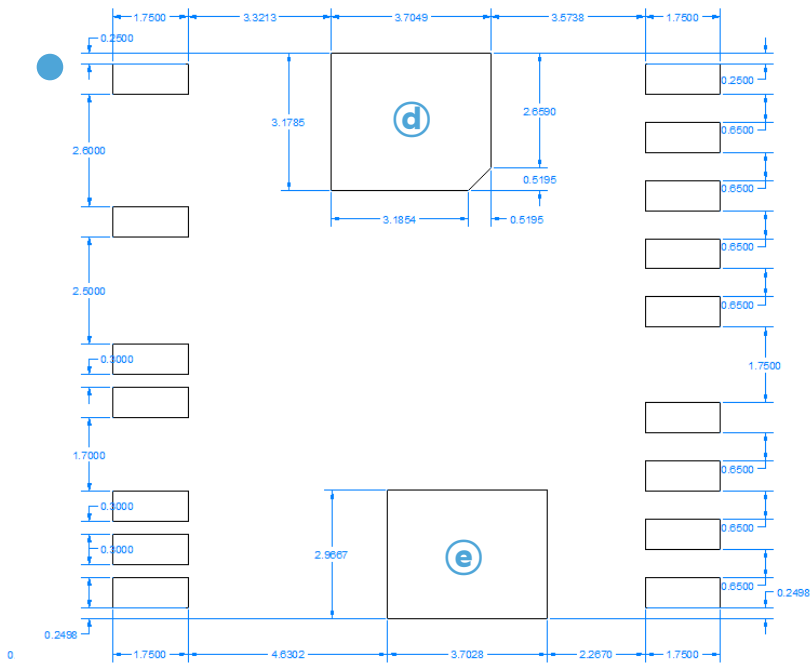

<SMJR-N-2-24>

Notes :

- 1) ①~③ : Thermal PAD (Recommended wide copper traces.)
- 2) ①~② : Electrical PAD do not connect to other devices(bleeder resistance – max. Power : 2W)
- 3) ③~③ : Electrical Isolated PAD.

Reflow Soldering Characteristics

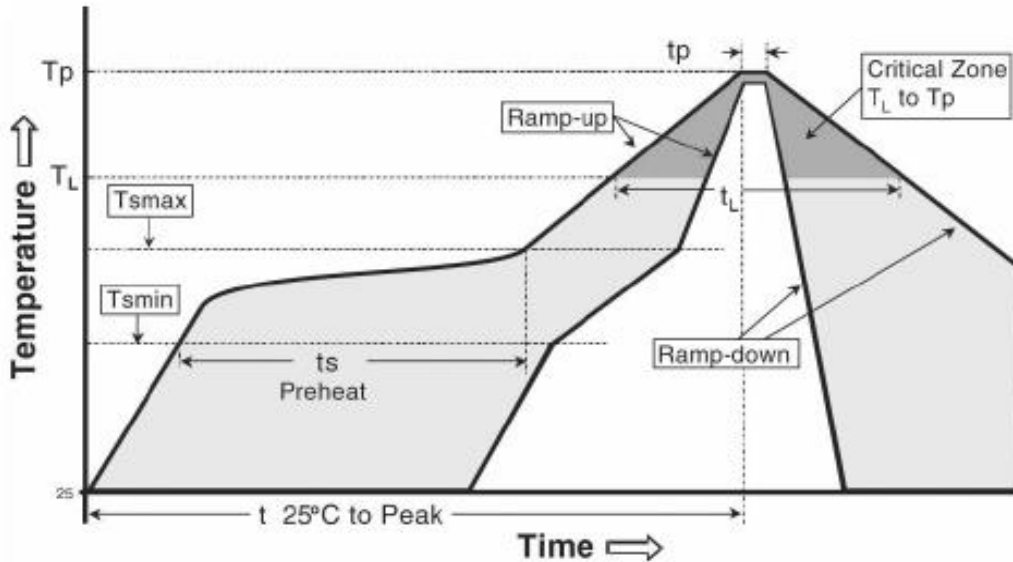

Profile Feature	Pb-Free Assembly
Average ramp-up rate (T_{smax} to T_p)	3° C/second max.
Preheat - Temperature Min (T_{smin}) - Temperature Max (T_{smax}) - Time (T_{smin} to T_{smax}) (t_s)	150 °C 180 °C 80-120 seconds
Time maintained above: - Temperature (T_L) - Time (t_L)	217~220°C 80-100 seconds
Peak Temperature (T_p)	250~255°C
Time within 5°C of actual Peak Temperature (t_p) ²	20-40 seconds
Ramp-down Rate	6 °C/second max.
Time 25°C to Peak Temperature	8 minutes max.
Atmosphere	Nitrogen ($O_2 < 1000ppm$)

Caution

- (1) Reflow soldering is recommended not to be done more than two times. In the case of more than 24 hours passed soldering after first, LEDs will be damaged.
- (2) Re-soldering should not be done after the LEDs have been soldered. If re-soldering is unavoidable, LED's characteristics should be carefully checked before and after such repair..
- (3) Do not put stress on the LEDs during heating.
- (4) After reflow, do not clean PCB by water or solvent.

SMT recommendation

- (1) Solder paste materials (SAC 305, No Cleaning Paste) → Senju M705-GRN360-KV

Marking Information

1. Seoul-semiconductor information

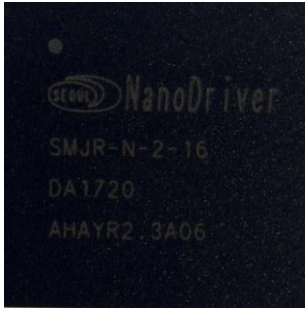

NanoDriver

①

SMJR-N-2-16

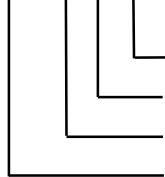

- ① Product Name (Fixed 10 Digits)
- ② SMJR – driver(Fixed 4 Digits)
- ③ N - Nano(1 Digit)
- ④ 2 – 230V (1 Digit)
- ⑤ 16 – Maximum Power (2 Digits)

2. CM information

DA1720

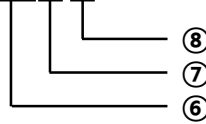

- ⑥ DA – DATE (Fixed 2 Digits)
- ⑦ 17 – Production year(2 Digits)
- ⑧ 20 – Production week(2 Digits)
- ⑨ Lot numbers(11 Digits)

AHAYR2.3A06

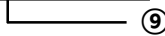

②		③		④		⑤		
SMJR		N		Typ. Voltage		Maximum Power		
Mark	Explain code	Mark	Explain code	Mark	Min	Max	Mark	Max.
SMJR	SSC internal Code	N	Nano driver	2	230		16	16
							24	24

Emitter Tape & Reel Packaging

(hole pitch cumulative tolerance: ± 0.2 , Unit: mm)

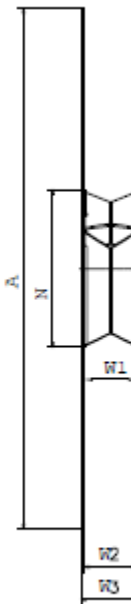
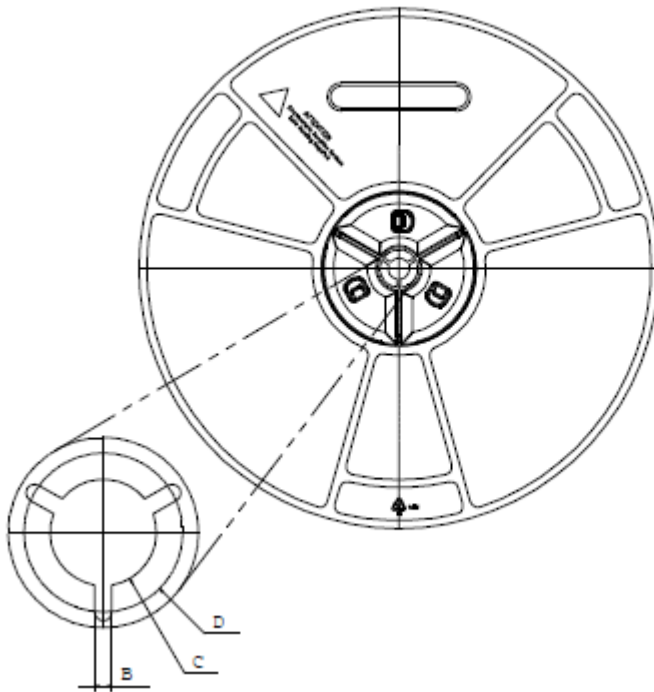
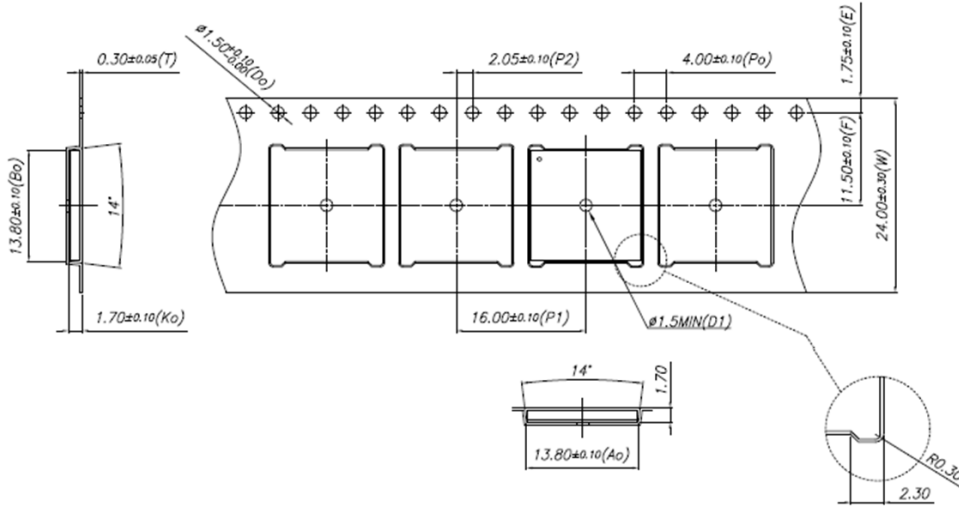

Size	24mm
A	330 ^{+0.2} _{-2.0}
B	1.5min
C	13.0 ^{+0.5} _{-0.2}
D	20.2min
N	100 ^{+3.0} _{-0.0}
W1	24.4 ^{+2.0} _{-2.0}
W2	24.4 ^{+2.0} _{-2.0}
W3	28.4 ^{+2.0} _{-2.0}

Notes :

- (1) Quantity : 2,000pcs/Reel
(empty slot possible in taping reel)
- (2) Cumulative Tolerance : Cumulative Tolerance/16 pitches to be ± 0.1 mm
- (3) Adhesion Strength of Cover Tape : Adhesion strength to be 0.1-0.7N when the cover tape is turned off from the carrier tape at the angle of 10° to the carrier tape
- (4) Package : P/N, Manufacturing data Code No. and quantity to be indicated on a damp proof package.

Packaging Information

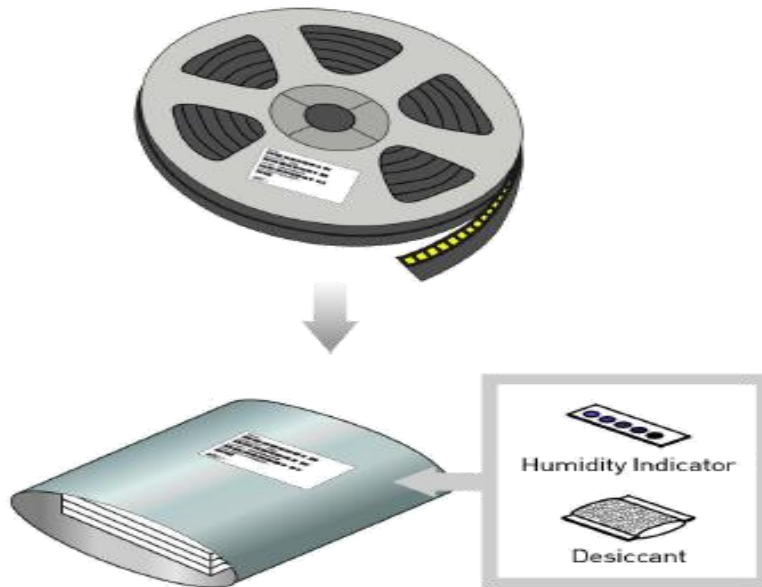

- Inner box is included sealing Al-bag
- Inner box size (340 x 325 x 50mm)
- 2,000 PCS Nano driver packed per inner box





- Outer box is included 5ea inner box
- Outer box size (380 x 340 x 380mm)
- 10,000 PCS Nano driver packed per outer box

Label Information

Model No.	SMJR-N-2-XX (1)
Quantity	XXXX
Date	YYMDDXXXXX-XXXXXXX
	SEOUL SEMICONDUCTOR CO.,LTD.

Notes :

- 1) The model number designation is explained as follow
 SMJR : Seoul Semiconductor internal code
 N : NanoDriver
 2 : 230V
 XX: 16 : use up to 16W / 24 : use up to 24W
- 2) It is attached to the side of Inner and outer box

TOTAL Quantity  XXXX
 SEOUL SEMICONDUCTOR CO.,LTD.

Notes :

- 1) It is attached to the bottom right corner of the outer box.

Precaution for Use

- (1) Please review the NanoDriver Application Note for proper protective circuitry usage.
- (2) Please note, NanoDriver products run off of high voltage, therefore caution should be taken when working near the NanoDriver products.
- (3) Make sure proper discharge prior to starting work.
- (4) DO NOT touch any of the circuit board, components or terminals with body or metal while circuit is active.
- (5) Please do not add or change wires while NanoDriver circuit is active.
- (6) Please do not assemble in conditions of high moisture and/or oxidizing gas such as Cl, H₂S, NH₃, SO₂, NO_x, etc.
- (7) Please do not make any modification on module.
- (8) Please be cautious when soldering to board so as not to create a short between different trace patterns.
- (9) Do not impact or place pressure on this product because even a small amount of pressure can damage the product. The product should also not be placed in high temperatures, high humidity or direct sunlight since the device is sensitive to these conditions.
- (10) When storing devices for a long period of time before usage, please following these guidelines:
 - * The devices should be stored in the anti-static bag that it was shipped in from Seoul-Semiconductor with opening.
 - * If the anti-static bag has been opened, re-seal preventing air and moisture from being present in the bag.
- (11) LEDs and IC are sensitive to Electro-Static Discharge (ESD) and Electrical Over Stress (EOS). The acrich3 product should also not be installed in end equipment without ESD protection.
- (12) LEDs and IC are sensitive to Electro-Static Discharge (ESD) and Electrical Over Stress (EOS). The NanoDriver product should also not be installed in end equipment without ESD protection.
- (13) Below is a list of suggestions that Seoul Semiconductor purposes to minimize these effects.

a. ESD (Electro Static Discharge)

Electrostatic discharge (ESD) is the defined as the release of static electricity when two objects come into contact. While most ESD events are considered harmless, it can be an expensive problem in many industrial environments during production and storage. The damage from ESD to an LEDs may cause the product to demonstrate unusual characteristics such as:

Precaution for Use

- Increase in reverse leakage current lowered turn-on voltage
- Abnormal emissions from the LED at low current

The following recommendations are suggested to help minimize the potential for an ESD event. One or more recommended work area suggestions:

- Ionizing fan setup
- ESD table/shelf mat made of conductive materials
- ESD safe storage containers

One or more personnel suggestion options:

- Antistatic wrist-strap
- Antistatic material shoes
- Antistatic clothes

Environmental controls:

- Humidity control (ESD gets worse in a dry environment)

b. EOS (Electrical Over Stress)

Electrical Over-Stress (EOS) is defined as damage that may occur when an electronic device is subjected to a current or voltage that is beyond the maximum specification limits of the device. The effects from an EOS event can be noticed through product performance like:

- Changes to the performance of the LED package
(If the damage is around the bond pad area and since the package is completely encapsulated the package may turn on but flicker show severe performance degradation.)
- Changes to the light output of the luminaire from component failure
- Components on the board not operating at determined drive power

Failure of performance from entire fixture due to changes in circuit voltage and current across total circuit causing trickle down failures. It is impossible to predict the failure mode of every LED exposed to electrical overstress as the failure modes have been investigated to vary, but there are some common signs that will indicate an EOS event has occurred:

- Damaged may be noticed to the bond wires (appearing similar to a blown fuse)
- Damage to the bond pads located on the emission surface of the LED package
(shadowing can be noticed around the bond pads while viewing through a microscope)
- Anomalies noticed in the encapsulation and phosphor around the bond wires
- This damage usually appears due to the thermal stress produced during the EOS event

c. To help minimize the damage from an EOS event Seoul Semiconductor recommends utilizing:

- A surge protection circuit
- An appropriately rated over voltage protection device
- A current limiting device



Company Information

Published by

Seoul Semiconductor © 2013 All Rights Reserved.

Company Information

Seoul Semiconductor (www.SeoulSemicon.com) manufactures and packages a wide selection of light emitting diodes (LEDs) for the automotive, general illumination/lighting, Home appliance, signage and back lighting markets. The company is the world's fifth largest LED supplier, holding more than 10,000 patents globally, while offering a wide range of LED technology and production capacity in areas such as "nPola", "Acrich", the world's first commercially produced AC LED, and "Acrich MJT - Multi-Junction Technology" a proprietary family of high-voltage LEDs.

The company's broad product portfolio includes a wide array of package and device choices such as Acrich and Acirch2, high-brightness LEDs, mid-power LEDs, side-view LEDs, and through-hole type LEDs as well as custom modules, displays, and sensors.

Legal Disclaimer

Information in this document is provided in connection with Seoul Semiconductor products. With respect to any examples or hints given herein, any typical values stated herein and/or any information regarding the application of the device, Seoul Semiconductor hereby disclaims any and all warranties and liabilities of any kind, including without limitation, warranties of non-infringement of intellectual property rights of any third party. The appearance and specifications of the product can be changed to improve the quality and/or performance without notice.